

Stylish Curtains, Blinds, Shutters,
Awnings, Louvre Roofs
& Insect Screens

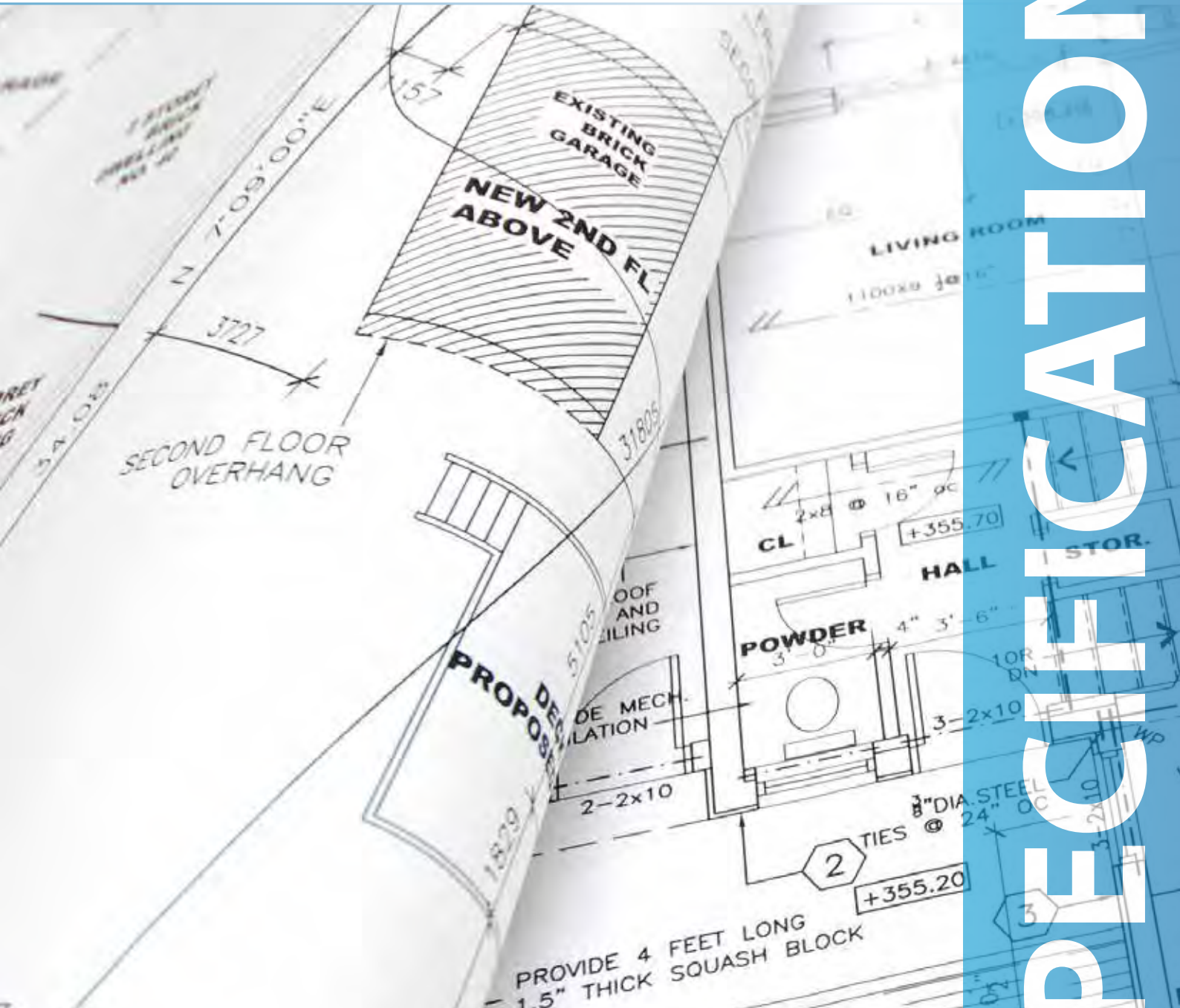

SPECIALTIES



www.window-treatments.co.nz

CONTENTS



INTRODUCTION

- COMPANY OVERVIEW
- SPECIFICATION OVERVIEW
- BRAND PARTNERS
- CUSTOMER SERVICE



ROLLER BLINDS

- HARDWARE
- RECESS BOXES
- SUNSCREEN
- LIGHT FILTERING
- BLOCKOUT
- MOTORISATION



BLOCCO BLINDS

- BLOCCO ROLLER BLIND
- BLOCCO HONEYCOMB BLINDS



CUSTOM MADE CURTAINS

- FABRICS
- HEADING STYLES
- CURTAIN TRACKS



MYSTIQUE (a curtain and blind in one)



HORIZONTAL BLINDS

- ALUMINIUM VENETIANS
- PAINTED TIMBER VENETIANS
- STAINED TIMBER VENETIANS
- NEW IMAGE VENETIANS



HONEYCOMB PLEATED BLINDS

- HONEYCOMB PLEATED



SHUTTERS

- TIMBER
- CEDAR
- ALUMINIUM
- PVC



AWNINGS

- ITALIA BOX
- PALLADIO

TERRAZZA PATIO AWNINGS

LOUVRE ROOF

SECURO® BLINDS

- SECURO® PULL DOWN
- SECURO® (CHANNEL GUIDE/WIRE GUIDE)
- SECURO® MAX
- SECURO SIDE ROLL



CAFÉ BLIND

OTHER

- VERTICAL BLINDS
- MAGNETIC INSECT SCREENS



MOTORISATION

- OVERVIEW
- ROLLER BLINDS
- HORIZONTAL BLINDS
- HONEYCOMB PLEATED
- AWNINGS - ITALIA BOX, PALLADIO
- TERRAZZA
- SECURO®
- CAFÉ BLIND
- SHUTTERS



Introduction

Company Overview

Window Treatments NZ Ltd, founded in 1984, is the largest independent blind, shutter, awning and insect screen manufacturing company in New Zealand.

We design and manufacture market leading products in our purpose built Christchurch factory and distribute via our own network of branches throughout New Zealand.

We employ over 140 people nationwide and also provide a blind cleaning and repair service through our subsidiary companies, Mr Sparkel Ltd in Auckland and Wellington and The Blind Care Company Ltd in Christchurch

Window Treatments NZ Ltd leads the market with a wide range of quality products, innovation, smart technology and attention to detail.

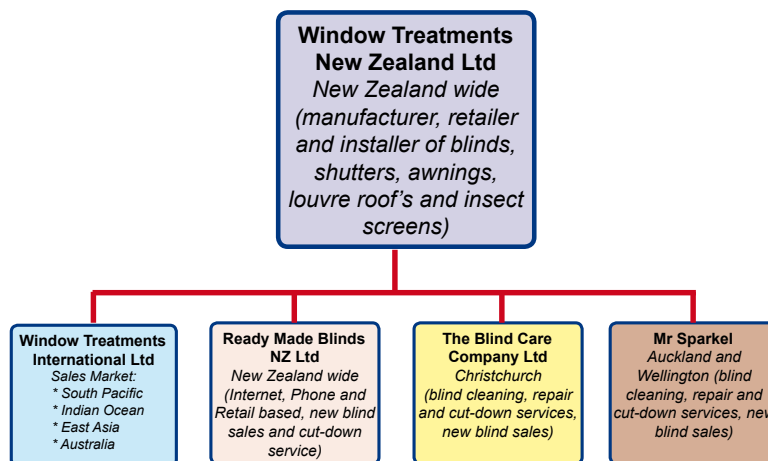

Specification Contents Overview

The specification folder contains technical information on all products with their matching specifications that can be used during the design process.

Specification information within these pages is regularly updated by Window Treatments NZ Ltd, however we encourage Architects and Specifiers to call us on 0800 36 36 39 or email sales@window-treatments.co.nz for clarification or additional information that may be required.



Window Treatments NZ Ltd

Brand Partners

The high quality products produced by Window Treatments NZ Ltd are made possible not only by its in-house quality control systems, but also by its careful selection of raw material supplier and service partners:

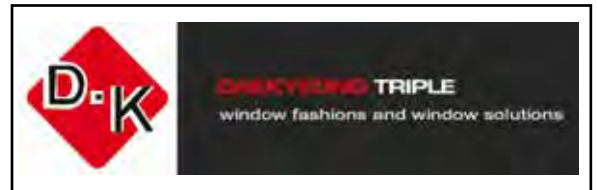

Window Treatments NZ Ltd

Head Office : P O Box 6260, Upper Riccarton,
Christchurch 8442, New Zealand
Freephone : 0800 36 36 39
Phone : +64 3 343 1876
Email : headoffice@window-treatments.co.nz

Customer Service

Management and staff in all facets of our business New Zealand wide, support and contribute to our goal of 100 percent customer satisfaction. No job is too big or too small and our team is vastly experienced in finding solutions to challenging commissions in both domestic and commercial applications.

SPECIFICATIONS

Masterspec - Listed Products



The following products are listed within Masterspec.
 Use your link to MASTERSPEC to access the following products
 (Note: if you are not currently registered with Masterspec visit www.masterspec.co.nz to register and download their software.)

Product Listings:

<p>5531W WINDOW TREATMENTS (INTERNAL ROLLER BLINDS)</p>	
<p>4522W WINDOW TREATMENTS (EXTERNAL ROLLER BLINDS)</p>	
<p>5261W WINDOW TREATMENTS (SHUTTERS)</p>	
<p>5544W WINDOW TREATMENTS (OUTDOOR AWNINGS)</p>	
<p>5530W WINDOW TREATMENTS (HORIZONTAL BLINDS)</p>	
<p>5531WH WINDOW TREATMENTS (HONEYCOMB PLEATED BLINDS)</p>	
<p>4522WL WINDOW TREATMENTS (LOUVRE ROOF SYSTEM)</p>	

The most recent electronic versions (PDF files) of the Window Treatments Specification Data can be downloaded at the Window Treatments NZ Ltd website from the "Architects and Designers" page at: <https://www.window-treatments.co.nz/technical-info/>

Sec. : Introduction
 Date : Jun 2021

www.window-treatments.co.nz

SPECIFICATIONS



Roller Blinds



SPECIFICATIONS

Hardware - Overview

Window Treatments' **RollEase**® system incorporates various operating systems for an entire range of coordinated, premium commercial/residential roller blind products. Colours available for the **RollEase**® Clutch Controller, Pin End, Brackets, Bracket Cover Plates and Bottom Rail End Caps are: White, Black.

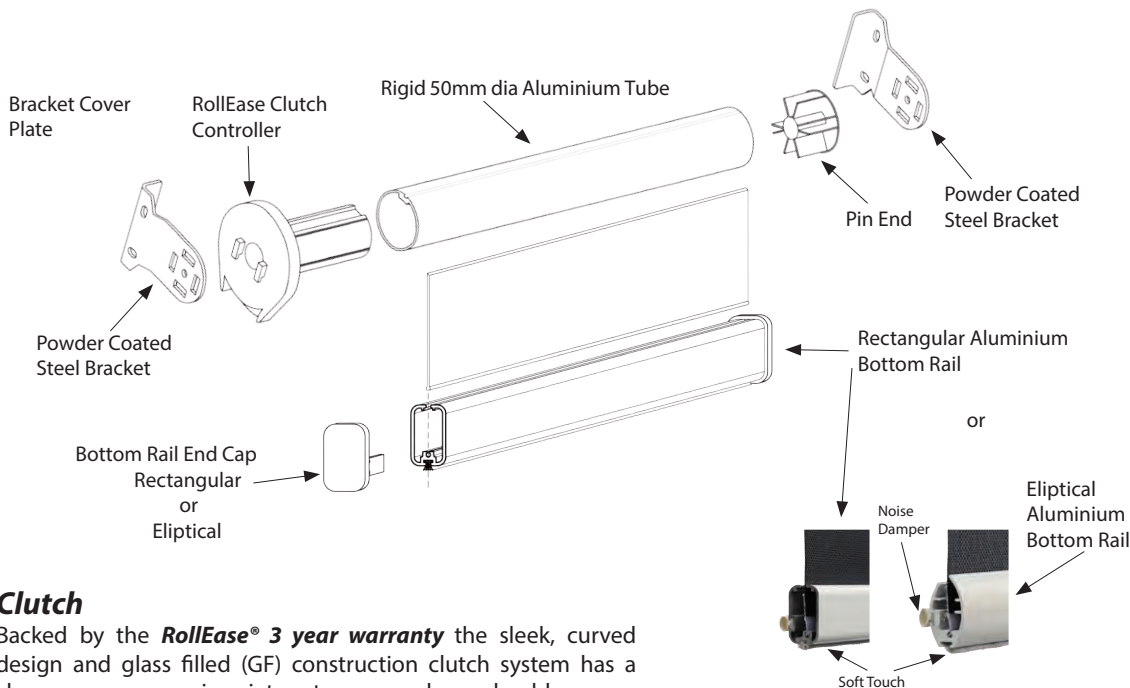

Clutch

Backed by the **RollEase**® 3 year warranty the sleek, curved design and glass filled (GF) construction clutch system has a cleaner appearance, is quieter, stronger and very durable.

HOW IT WORKS

A clutch utilises a wrap spring which can either be tightened or loosened on an inner core. Push on one side of the spring tang and the spring diameter decreases locking the clutch and prevents any movement. Push the tang on the other side and the spring opens, allowing free movement. The clutch is divided into two separate interior, interlocking cores, the first of which is on the outside (blind tube housing) where the roller blind tube is attached (fabric is rolled onto the tube). The inner core is attached to the cord guard. Both cores have cams which are arranged to push on a particular side of the spring tang. With **Velvetrol**™, this core is open on two opposing sides. **Velvetrol**™ enables the spring tangs to apply a balanced force on both sides at the same time allowing a more smooth and even distribution of forces.

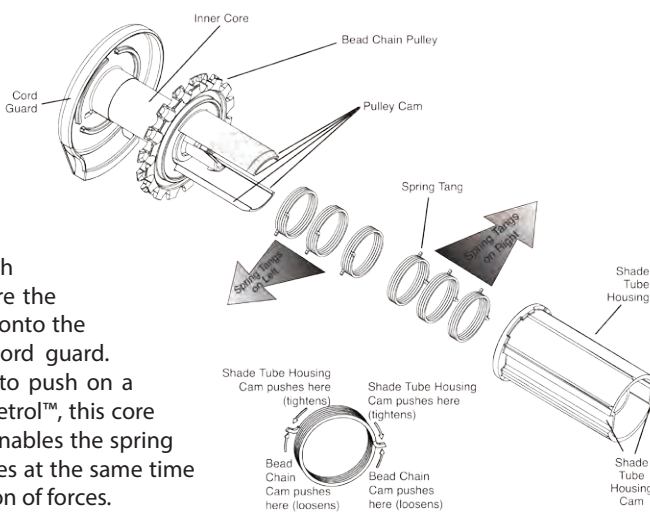

The pulley has a cam on both sides which is positioned in such a way that when the pulley is moved in either direction (by pulling on the bead chain) it pushes against the spring tang opening the spring's diameter and allowing the blind to move up and down. Release the bead chain and the spring automatically returns to its original, closed shape, locking the blind in position.

The blind tube housing has a cam positioned so that the force of the hanging blind pushes on the side of the spring tang locking it to the inner core. The weight of the blind helps keep the blind locked. The more weight on the blind, the tighter the spring locks. The **RollEase**® patented, balanced core **Velvetrol**™ multi-spring configuration distributes the interior forces evenly over the inner core and offers the industry's smoothest pull. The ratio between the bead chain pulley and the blind tube provides a mechanical advantage, allowing the pull forces to raise a blind to be less than the actual weight of the blind.

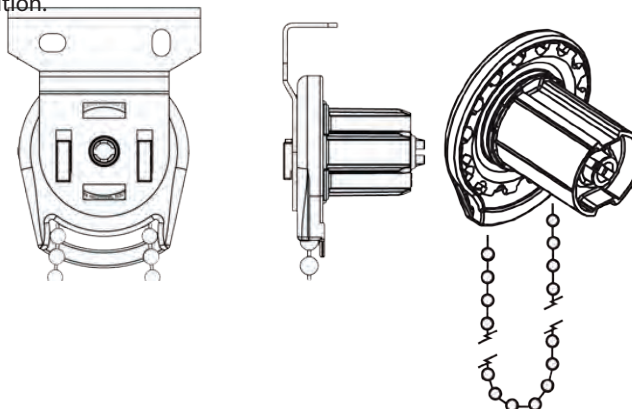

SPECIFICATIONS

Pin End

The RollEase® Skyline spring loaded pin-end and the Skyline 50mm – 63mm heavy-duty spring loaded pin-end, allows for easier installation of the blind into the bracket. The spring loaded pin maintains a constant tension on the blind assembly within the bracket preventing the blind from rolling out of the brackets and reducing drag on the drive system. The pin-end consists of an outer stationary housing and is made of glass reinforced nylon. The bearing surface is a spring loaded pin end engaged into the centre of the housing, made of proprietary General Electric Plastics lubricated PF30 material. The bearing surface provides smooth wear resistance operation. Colours available: White, Black.



Skyline Standard Pin End



Skyline Heavy Duty Pin End

Control Chain

The control chain for the RollEase® clutch system is supplied with three chain type options:

1. Plastic beaded chain with polyester cord,
2. Nickel plated steel chain,
3. Stainless Steel chain.

We recommend the plastic beaded chain with polyester cord because it is stronger, contains no risk of corrosion and runs more quietly when the blind is raised and lowered. The plastic beaded chains are thermally fused 0.175" Dia. plastic bead onto a heavy duty 0.065" Dia. continuous nylon cord. Colours available: White, Black.

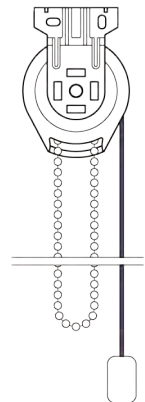

Geared Controller (for blinds 5m² up to 12m²)

The Galaxy G200 & G400 geared controllers provide easier raising and lowering compared to the standard non-geared SL15 and SL20 controllers. Both geared controllers are suitable for residential and commercial applications. The G200 is used on 50mm tubes and the G400 is only used for very large blinds with a 63mm tube. The G200 & G400 geared controllers feature advanced geared patented technology known as Velvetrol and are designed with sleek rounded chain guard profiles.



Fabric Fastening

Window Treatments has developed a unique welding system for attaching the fabric of a roller blind to the roller tube and bottom rail. The new and exclusive **Fabric Fastening** system uses a high impulse electric welding machine to weld the spline onto the fabric which is then guided into the rails through a specially formed groove.

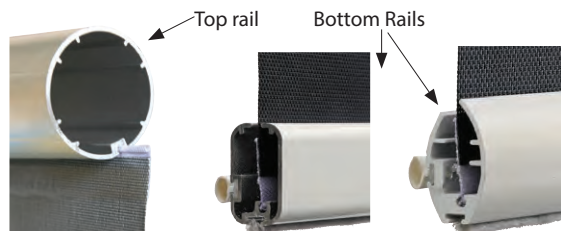

Hardware - Options

Multi-Link Blinds

RollEase® has developed a superior multi-link system, allowing multi-link blinds for wide or multi panel glazing without compromising operation. The multiple-link system allows for adjustments in the roller blind height from one linked roller blind to the other. Up to three roller blinds can be linked together with an option of manual or motorisation operating systems.

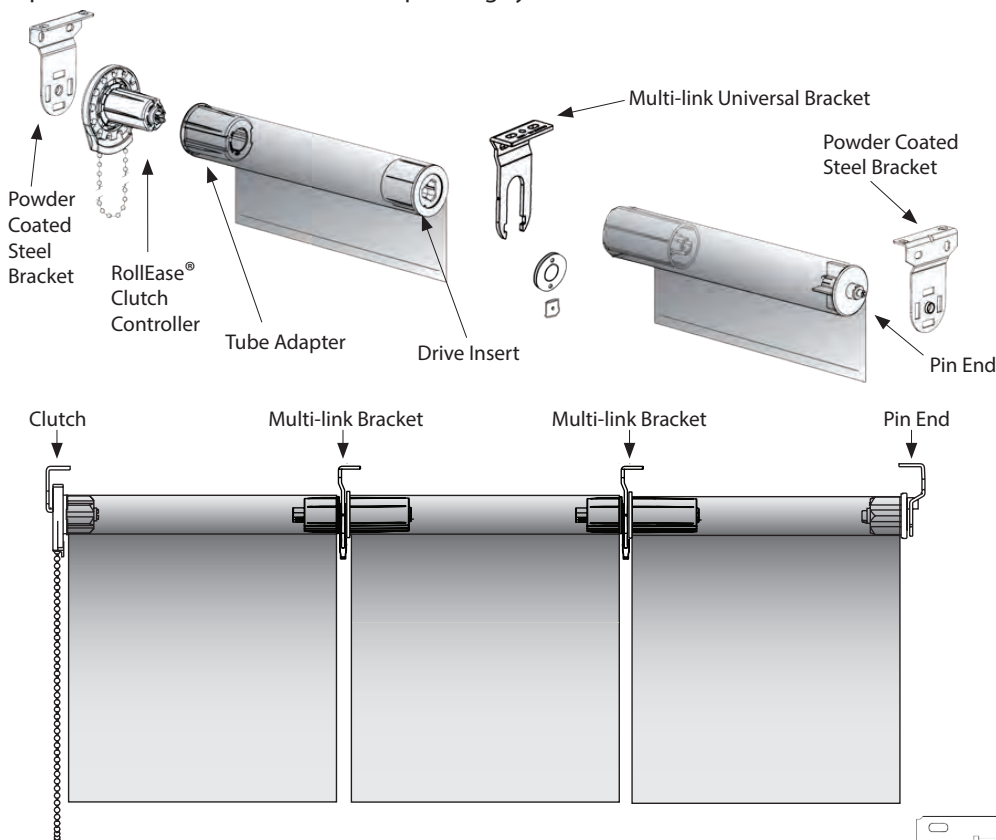

Double Roller

A double roller system has been developed for customers who require both a transparent solar screen fabric and a block-out fabric on the same window. A double roller can also be used when multiple-link blinds are required. Control operations can either be manual or motorised.

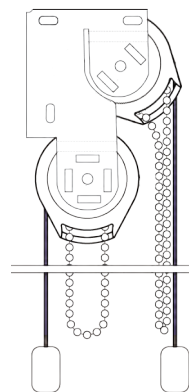

Motorisation

Window Treatments uses motors and control systems by French company Somfy® (Hard wire motors) and also Rollease Acmeda® (Automate Wirefree and Hard wire motors), both of whom are considered world leaders in automated systems and blind hardware. For further information refer to our Automation section or contact motorisation@window-treatments.co.nz

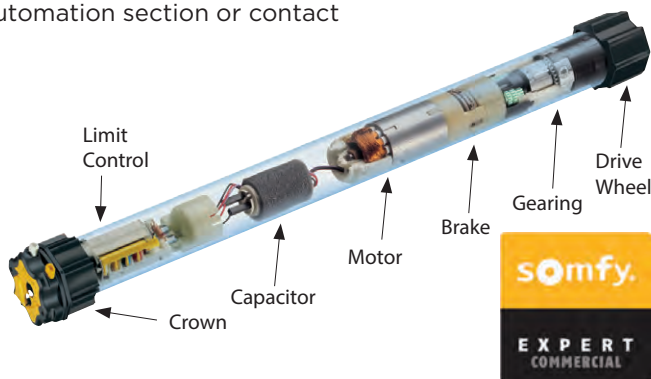

Roller Blind Wire Guide

The Roller Blind Wire Guide is designed for perpendicular opening windows with a maximum of 15 degrees incline from vertical and for blinds with drops exceeding 3500mm. The side wires provide stability and control of the blind when lowered or raised and can be fitted to both single and double Roller blinds. Note: wire guides are not designed for wind loading

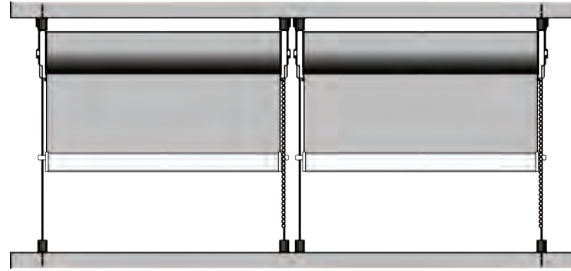

- Suitable for perpendicular windows with a maximum of 15 degrees incline from vertical.
- Suitable for Single and Double Roller blinds.
- Wire is stainless steel 1.5mm (7x7 ASIS T316) which passes through stainless steel eye bolts connected to the bottom rail.
- The wire is fastened by stainless steel top and bottom wire connectors.
- Bottom rails are either elliptical or rectangular. Both bottom rails have a Soft Touch feature.
- Bottom rails are available in White, Ivory, Chinchilla, Silver Pearl, Bronze, Anthracite, Black or Anodised with Polypropylene end caps in: Black, White.

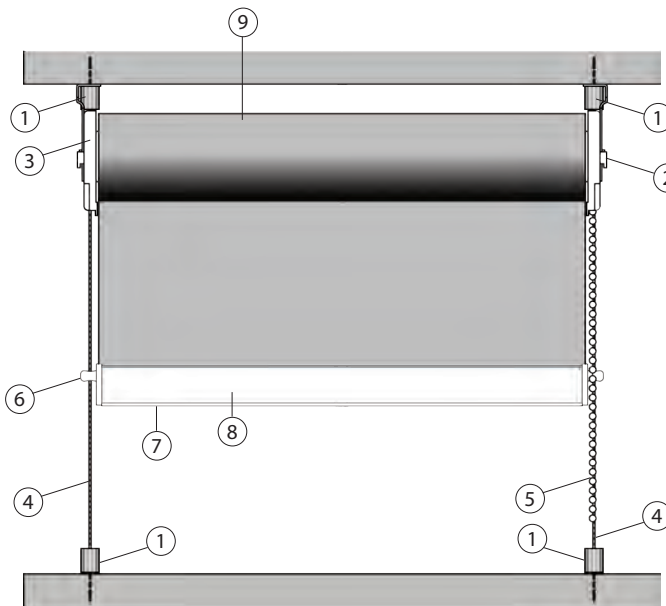

Key Numbers

1. Stainless Steel Top and Bottom Wire Connector
2. Powder Coated Steel Bracket
3. Bracket Cover Plate
4. Stainless Wire 1.5mm (7x7 ASIS T316)
5. Control Chain
6. Stainless Steel Eye Bolts
7. Soft Touch (optional, Grey colour only)
8. Aluminium Bottom Rail
9. Roller Tube

Cord Tidy

The chain tensioning devices (Cord Tidy) are designed to hold beaded plastic or nickel plated steel ball chain. There are two types of Cord Tidy: one for mounting to the window frame and one for free hanging. The tensioning devices provide easy pull and when they are fixed to the window frame it also reduces the risk of injury, particularly for children.

Colours available for wall/window frame mounting device: White, Black. Colours available for free hanging device: Light Grey, White, and Black.

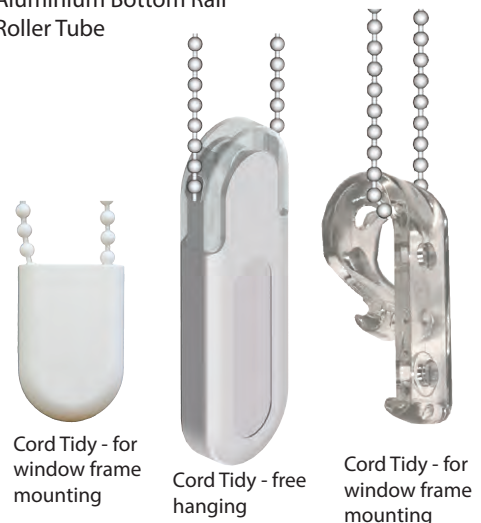

Soft Touch & Noise Damper

To minimise noise level and draughts when lowering the blind onto the window sill, Window Treatments has developed a Soft Touch system and also a noise Damper system which are guided into the bottom rails through two specially formed grooves.

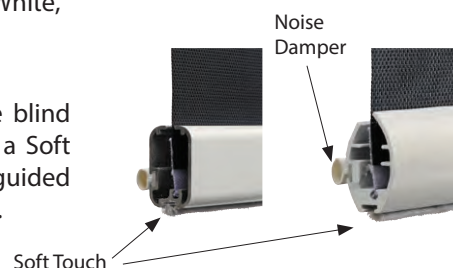

Hardware - Front & Back Roll Combinations

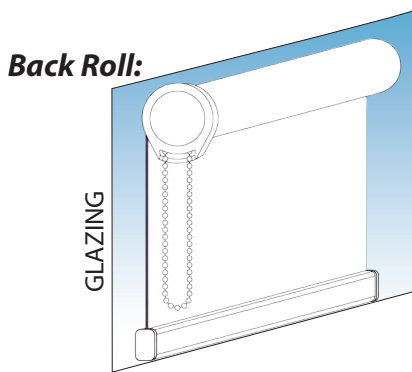

Back Roll:
This is the most popular way of having the fabric hang off a roller blind tube. It keeps the fabric close to the window glass, allows easy access to the chain control and also keeps the fabric close to the wall when Face Fix mounting the blinds.

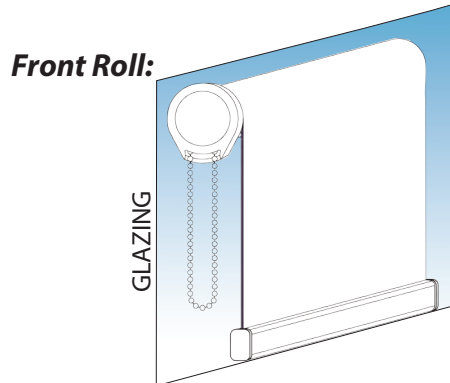

Front Roll:
Ideal for the customer who does not want to see the roll at the top of their window. The fabric comes over the front of the roller blind tube so the tube is hidden from view. A front roll also provides more clearance from any obstructions such as window catches and handles. However access to the chain control is more limited and care needs to be taken when raising or lowering the blinds to avoid damage to the fabric edge.

Roll Direction



Bottom Rail Options

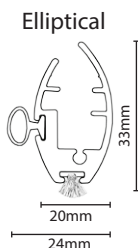

Elliptical Bottom Rail
- with end cap - without end cap
33mm x 20mm 30mm x 16mm

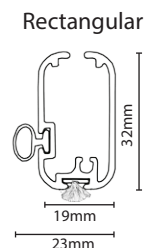
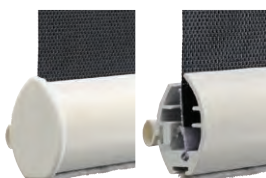

Rectangular Bottom Rail
- with end cap - without end cap
32mm x 19mm 29mm x 16mm

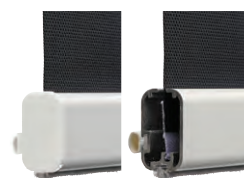

SPECIFICATIONS



Hardware - Single Roller Options

SPECIFICATIONS

Single Roller Brackets

Single Roller Brackets are ideal for most window frames as there is no need for a right and left style bracket. They are suitable for both Top Fix and Face Fix installations. Matching Cover Plates come standard for Face Fix installations. Colours available: White, Black.

Bracket Cover Plates

Bracket Cover Plates are standard for: Single Roller Face Fix, and Standard Double Roller Face Fix. Colours available: White, Black.

Please Note: The actual projection of the roller blind (tube & fabric) is variable depending on the drop of the window.

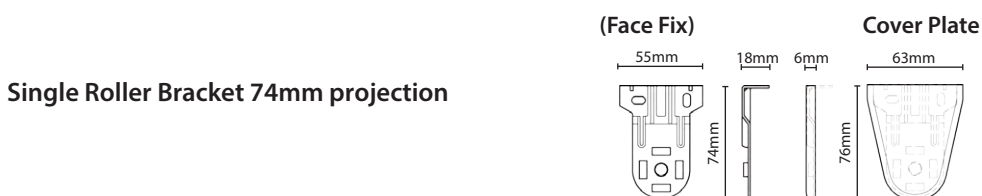
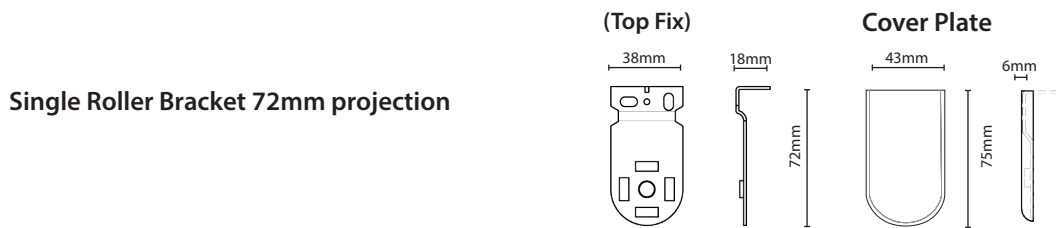
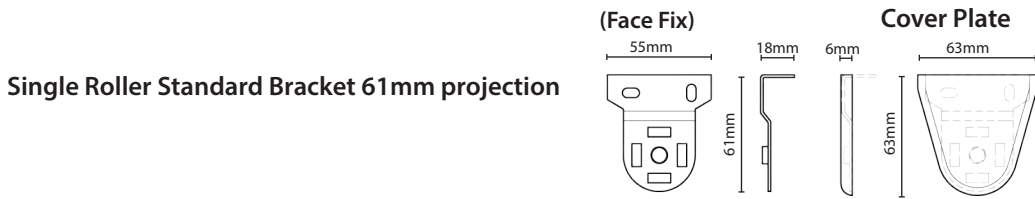
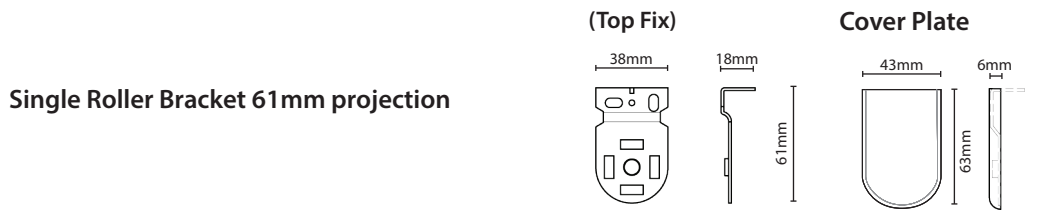

Hardware - Single Roller Options

Single Roller Bracket 94mm projection

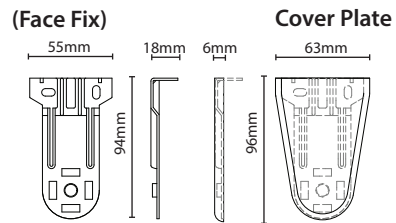

Bracket covers slide over the bracket until snapped into position.

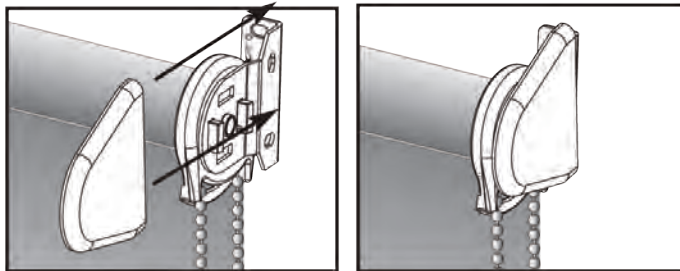

Bracket Specification

Brackets are constructed of 0.06 inch thick nickel-plated, C1080/1010 cold rolled steel. The brackets are universal for example working on the clutch or pin end. Colours available: White, Black.

Single Roller Universal Bracket for 50mm tube

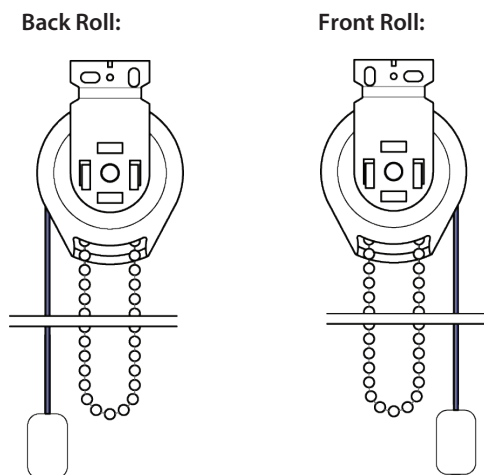

Window Treatments' Recess Boxes - Overview

Made from extruded aluminium, this sleek modular system allows single or double motorised blinds and curtains to be concealed completely within the ceiling space.

For Roller Blinds, a removable bottom cover leaves only a small slit visible which the blind lowers from and retracts into.

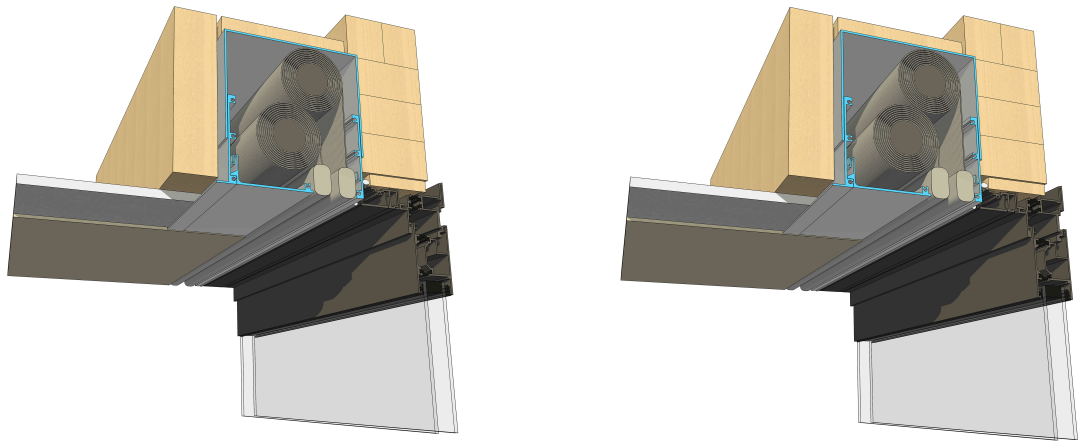

Features:

- Modular recessed box for single and double motorised roller blinds, curtain tracks and headings
- Standard 4.2m long recess box can be shortened or lengthened to custom size
- Standard width and height recess box, 4.2m long profile made from nominal 2mm gauge extruded aluminium
- Option for a "Part Recess" Box (single or double)
- Non standard recess box sizes can be supplied when construction/design limitations exist. P.O.A
- A removable extruded aluminium bottom cover concealing the blind within (Curtain tracks and headings do not have a bottom cover)
- Bottom recess cover can be connected either at the front or the back internal edge of the recess box
- The sides of the recess box can be either flangeless for negative detail or flanged to provide a tidy cover of the ceiling gib/plaster edge
- Additional recess box aluminium end cap covers supplied as standard flangeless, or you can choose a flanged end cap cover
- Mill/Raw finish, Standard Powder Coated (SPC) black or white, or Custom Powder Coated (CPC)
- Option for an LED strip lighting to be fitted inside the recess box
- Available for collection at Window Treatments Auckland, Hamilton, Wellington, Nelson, Christchurch, Dunedin and Cromwell
- Delivery to site P.O.A
- PDF and DWG downloads available

Recess Box Configuration Options for Single Blinds

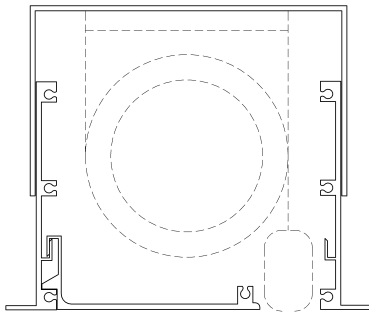

Single Box
2 Side Flanges
A-SB2SF

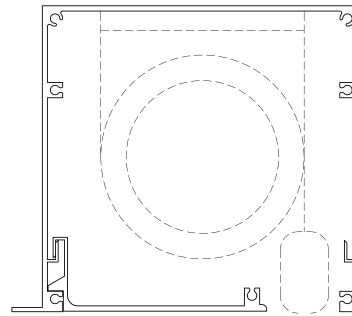

Single Box
1 Side Flange
B-SB1SF

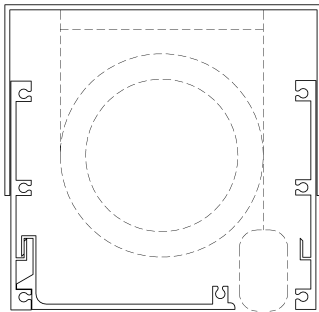

Single Box
No Side Flanges
C-SB0SF

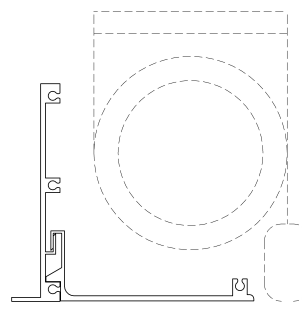

Single Part Box
1 Side Flange
SPB1SF

Part box option allows the builder and architect some flexibility of box dimensions for unique applications. Contact Window Treatments for more information.



End Cap (EC) with or without End Flange (EF)

SPC = Standard Powder Coated
CPC= Custom Powder Coated

NOTE ON SINGLE OR DOUBLE RECESS BOXES

Recess Box available in Raw/Mill finish or Standard Powder Coated (SPC) black or white, or Custom Powder Coated (CPC). Installation of Recess Box by the Construction Company.
Installation of Blinds and Bottom Cover by Window Treatments NZ Ltd.

Recess Code	Box Width (excluding side flange)	Box Height	Profile Lengths	Maximum Blind Drop	Reversible Bottom Cover Y/N	End Caps (EC)	End Caps With Flanges (EF)
A-SB2SF	125mm	120mm	4200mm	3500mm	Y	Optional	Optional
B-SB1SF	125mm	120mm	4200mm	3500mm	Y	Optional	Optional
C-SB0SF	125mm	120mm	4200mm	3500mm	Y	Optional	Optional
SPB1SF	(variable)	(variable)	4200mm	N/A	N/A	Optional	Optional

Recess Box Configuration Options for Double Blinds

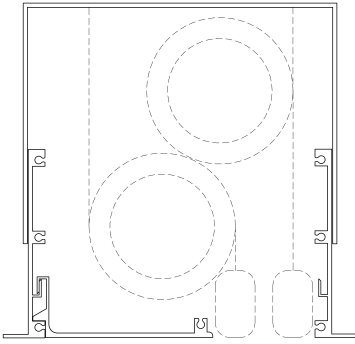

Double Box
2 Side Flanges
A-DB2SF

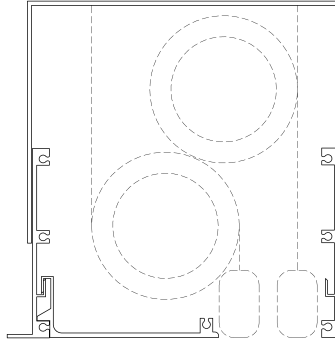

Double Box
1 Side Flange
B-DB1SF

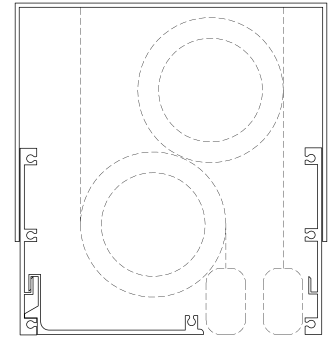

Double Box
No Side Flanges
C-DB0SF

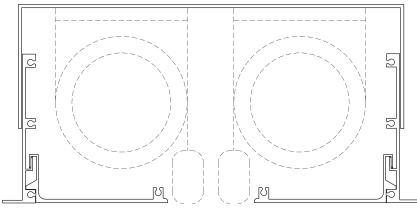

Double Box
2 Side Flanges
D-DB2SF

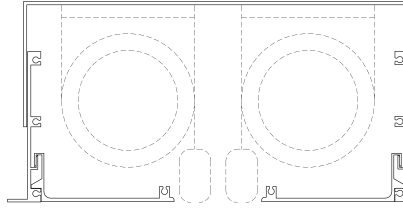

Double Box
1 Side Flange
E-DB1SF

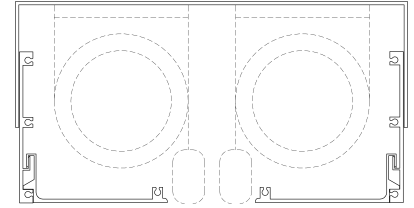

Double Box
No Side Flanges
F-DB0SF

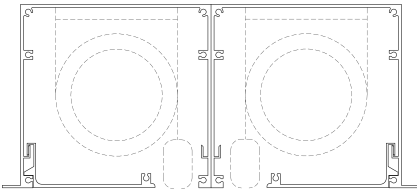

Double Box
2 x singles side by side. 2 Side Flanges
G-DBSS2SF

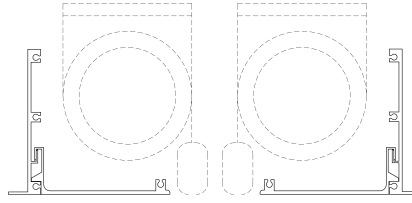

Double Part Box
2 Side Flanges
DPB2SF

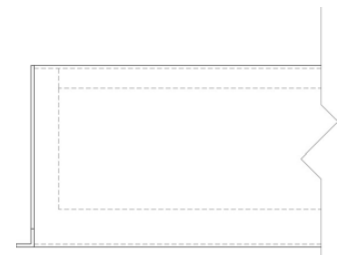

End Cap (EC) with or without End Flange (EF)

Part box option allows the builder and architect some flexibility of box dimensions for unique applications. Contact Window Treatments for more information.

Recess Code	Box Width (excluding side flange)	Box Height	Profile Lengths	Maximum Blind Drop	Reversible Bottom Cover Y/N	End Caps (EC)	End Caps With Flanges (EF)
A-DB 2SF	150mm	160mm	4200mm	2800mm	Y	Optional	Optional
B-DB1SF	150mm	160mm	4200mm	2800mm	Y	Optional	Optional
C-DB0SF	150mm	160mm	4200mm	2800mm	Y	Optional	Optional
D-DB2SF	234mm	120mm	4200mm	3500mm	Y	Optional	Optional
E-DB1SF	234mm	120mm	4200mm	3500mm	Y	Optional	Optional
F-DB0SF	234mm	120mm	4200mm	3500mm	Y	Optional	Optional
G-DBSS2SF	250mm	120mm	4200mm	3500mm	Y	Optional	Optional
DPB2SF	(variable)	(variable)	4200mm	N/A	N/A	Optional	Optional



Recesses constructed by the Builder

If a Window Treatments Recess box is not being used and the builder is instead constructing a recess, see the specifications below for the cavity sizes required to house the blinds:

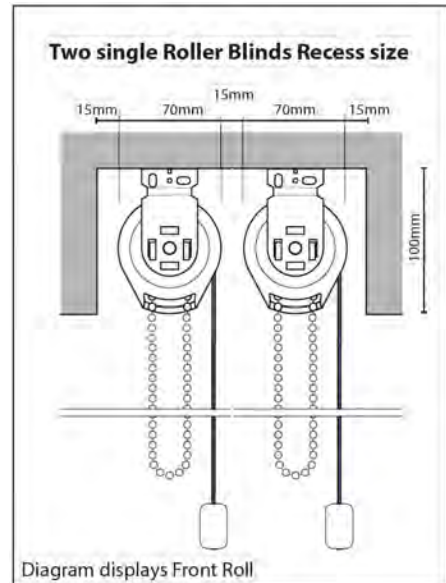
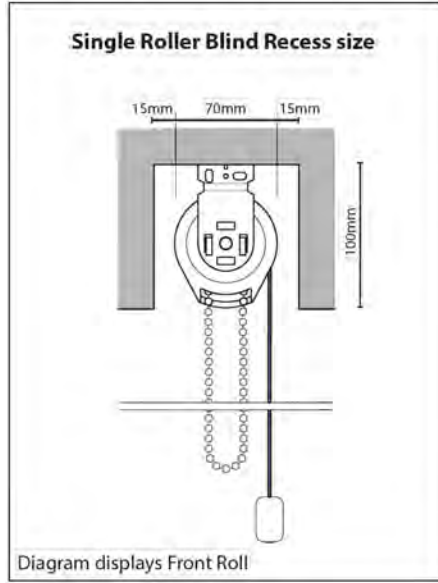

Automation for Recess Blinds

Window Treatments NZ recommends RTS control when blinds are to be installed inside a recess.

Hardware - Double Roller Options

Standard Compact Double Roller Bracket

Standard Compact Double Roller Brackets are narrow and reliable. Available for right and left mounts, they are great for narrow window frames and offer greater flexibility when mounting two roller blinds in one opening, creating room darkening and ambient light control. Our standard Double Roller Bracket can mounted in either Top Fix or Face fix applications. Colours available are: White, Black.

Standard Compact Double Roller Standard Bracket
127mm projection

(Top and Face Fix)

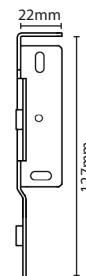
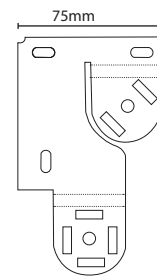

Cover Plate

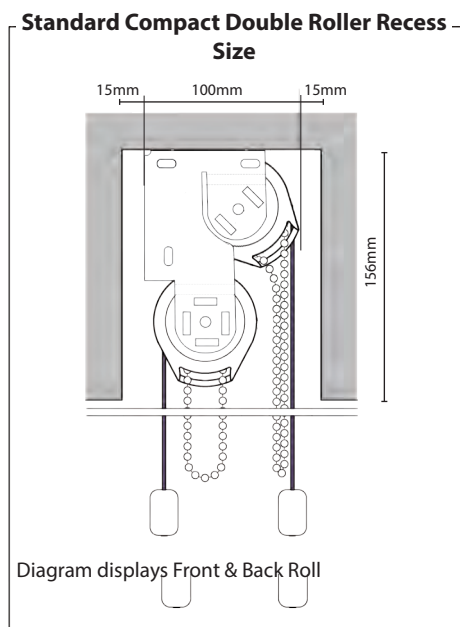
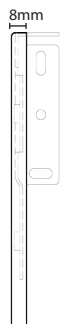
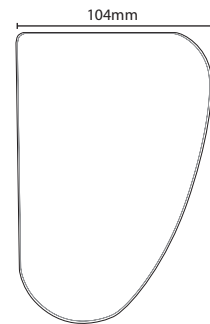

Back and Front Roll:

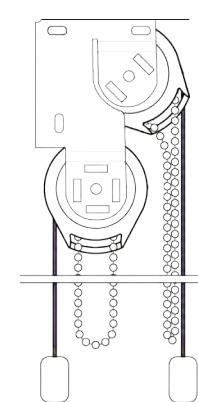

Front and Front Roll:

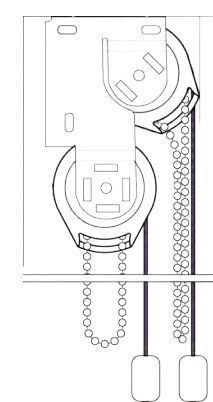

Automation for Recess Blinds

Window Treatments NZ recommends RTS control when blinds are to be installed inside a recess.

Hardware - Double Roller Options

Slimline Double Roller Bracket

Our Slimline Double Roller Brackets are Top Fix only and suited to an inside (perpendicular) fit. Colours available are: White, Black.

Slimline Double Roller Bracket
144mm perpendicular projection

(Top Fix, inside perpendicular fit only)

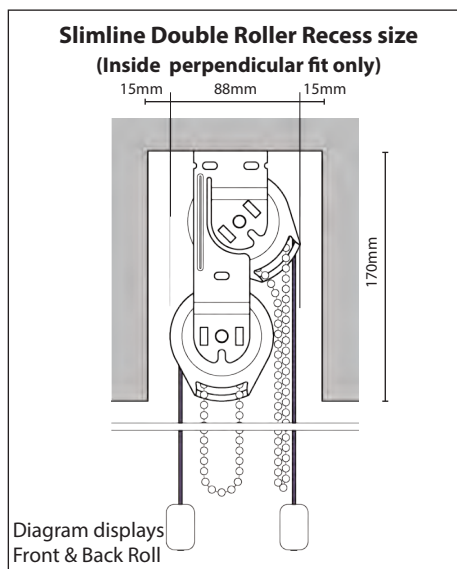
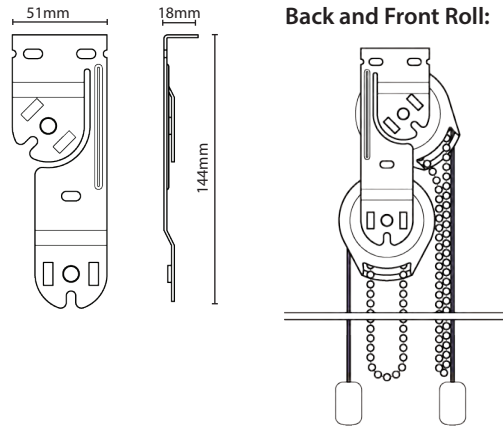

Automation for Recess Blinds

Window Treatments NZ recommends RTS control when blinds are to be installed inside a recess.

Double Roller Brackets

Double Roller Brackets offer greater flexibility when mounting two roller blinds in one opening to create room darkening and ambient light control. They are available in two sizes, 102mm and 122mm projection. Brackets can be mounted to the ceiling or wall and there is no need for a right and left style bracket. The use of Double Roller Brackets allows for proper alignment resulting in a better overall installation. When installation requires the double roller blind to be Face Fix, matching Cover Plates will come standard with this application. Colours available: White, Black.

Double Roller Bracket 102mm

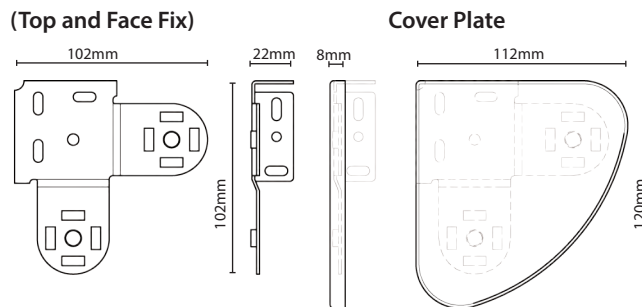

Hardware - Double Roller Options

Double Roller Bracket 122mm projection

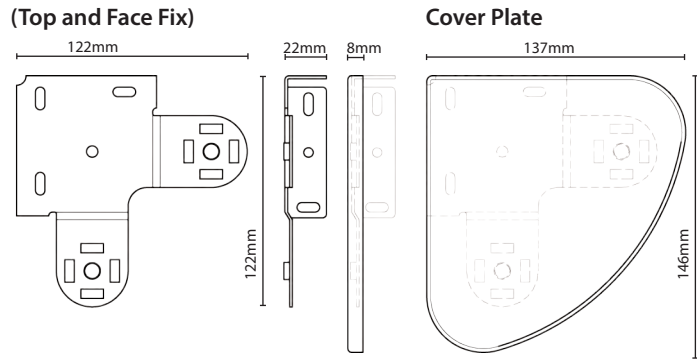

Double Roller Bracket

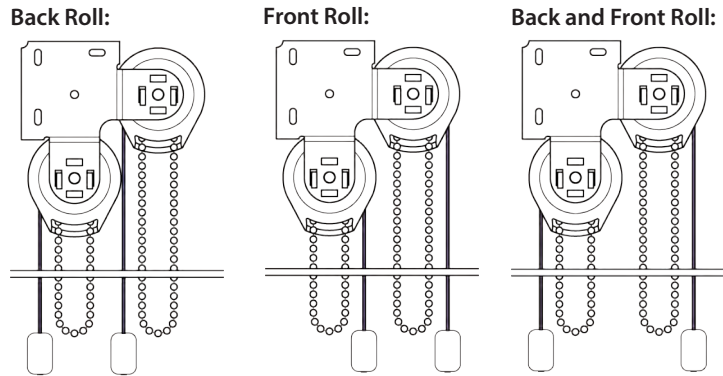

Automation for Recess Blinds

Window Treatments NZ recommends RTS control when blinds are to be installed inside a recess.

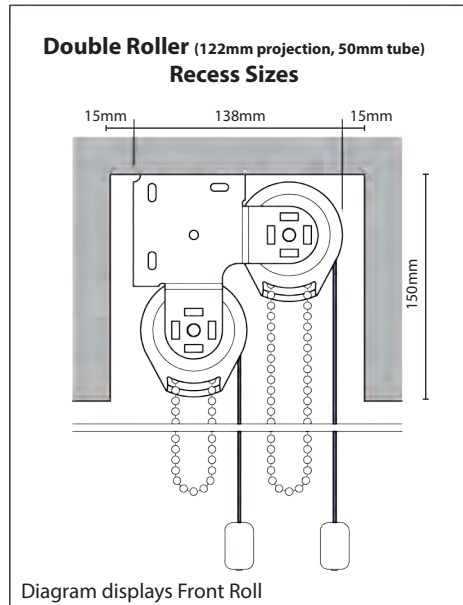

Hardware - Single Roller Options



Maximum Size Guidelines (based on 50mm tube size & subject to fabric choice)

Please Note : These measurements are guidelines only and Window Treatments can generally manufacture roller blinds outside these guidelines as required. For example if a blind has drop greater than 3500mm, we may use a RollEase's® Galaxy series clutch planetary gear system a greatly reduces the chain pull force needed to lift heavy or long drop blinds. We recommend blinds with drops exceeding 3500mm are installed with wire guides.

Key

Intermediate Bracket Allows blinds to operate independently 	Multi Blind Universal Bracket Allows up to 3 blinds to operate together 	Geared Clutch Allows blinds to be raised with less effort
---	---	---

Description	Controls	Control Options	
		Motorised Y/N	Manual Y/N
SINGLE CHAIN CONTROL ROLLER BLIND 	LEFT OR RIGHT	Y	Y

Description	Controls & Geared Clutch	Motorised Y/N	Manual Y/N
2 ROLLERS LINKED TOGETHER WITH A MULTI BLIND UNIVERSAL BRACKET & 1 GEARED CLUTCH 	LEFT OR RIGHT	Y	Y

Description	Controls	Motorised Y/N	Manual Y/N
2 ROLLERS LINKED TOGETHER WITH AN INTERMEDIATE BRACKET. ALLOWS FOR INDIVIDUAL CONTROL. 	LEFT OR RIGHT on either blind	Y	Y

SPECIFICATIONS

Hardware - Single Roller Options

Description	Controls & Geared Clutch	Control Options	
		Motorised Y/N	Manual Y/N
3 ROLLERS LINKED TOGETHER WITH 2 MULTI BLIND UNIVERSAL BRACKETS, 1 CONTROL & 1 GEARED CLUTCH. ALLOWS 3 BLINDS TO BE RAISED TOGETHER.	LEFT OR RIGHT	Y	Y

Description	Controls	Geared Clutch	Motorised Y/N	Manual Y/N
3 ROLLERS LINKED TOGETHER WITH 1 INTERMEDIATE BRACKET, 1 MULTI BLIND UNIVERSAL BRACKET, 1 GEARED CLUTCH & 2 CONTROLS. ALLOWS 2 BLINDS TO BE RAISED TOGETHER AND 1 INDEPENDENTLY.	LEFT OR RIGHT on either blind	RIGHT	Y	Y

Description	Controls	Geared Clutch	Motorised Y/N	Manual Y/N
3 ROLLERS LINKED TOGETHER WITH 1 INTERMEDIATE BRACKET, 1 MULTI BLIND UNIVERSAL BRACKET, 1 GEARED CLUTCH & 2 CONTROLS. ALLOWS 2 BLINDS TO BE RAISED TOGETHER AND 1 INDEPENDENTLY.	LEFT OR RIGHT on either blind	LEFT	Y	Y

Description	Controls	Geared Clutch	Motorised Y/N	Manual Y/N
4 ROLLERS LINKED TOGETHER WITH 2 GEARED CLUTCH, 2 MULTI BLIND UNIVERSAL BRACKETS, 1 INTERMEDIATE BRACKET. ALLOWS 2 SETS OF 2 BLINDS TO BE RAISED INDEPENDENTLY.	LEFT AND RIGHT on either blind	LEFT OR RIGHT	Y	Y



Note:

A Geared clutch is not required on Roller Blinds when motorisation has been selected.

Hardware - Double Roller Options



Key

Intermediate Bracket Allows blinds to operate independently 	Multi Blind Universal Bracket Allows up to 3 blinds to operate together 	Geared Clutch Allows blinds to be raised with less effort 
--	--	---

Description	Controls	Control Options	
		Motorised Y/N	Manual Y/N
DOUBLE ROLLER BLINDS WITH CONTROLS AT OPPOSITE ENDS. 	LEFT AND RIGHT	Y	Y

Description	Controls	Motorised Y/N	Manual Y/N
DOUBLE ROLLER BLINDS WITH CONTROLS AT SAME END. 	LEFT OR RIGHT	Y	Y

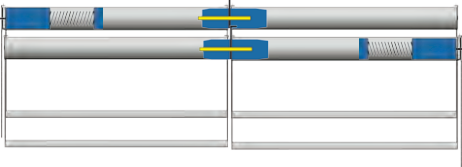
Description	Controls & Geared Clutch	Motorised Y/N	Manual Y/N
2 DOUBLE ROLLER BLINDS LINKED TOGETHER WITH A DOUBLE MULTI BLIND UNIVERSAL BRACKET & 2 GEARED CLUTCH. CONTROLS AT OPPOSITE ENDS WITH AS GEARED CLUTCH. 	LEFT AND RIGHT	Y	Y

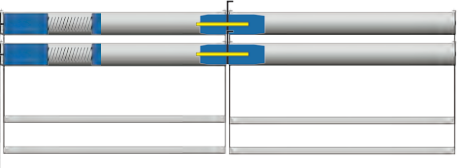
Description	Controls & Geared Clutch	Motorised Y/N	Manual Y/N
2 DOUBLE ROLLER BLINDS LINKED TOGETHER WITH A DOUBLE MULTI BLIND UNIVERSAL BRACKET & 2 GEARED CLUTCH. CONTROLS AT SAME END AS GEARED CLUTCH. 	LEFT OR RIGHT	Y	Y

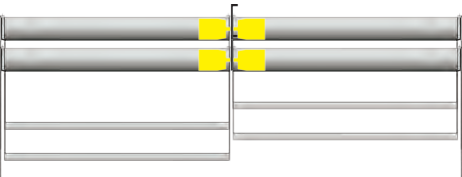
Description	Controls	Motorised Y/N	Manual Y/N
2 DOUBLE ROLLER BLINDS LINKED TOGETHER WITH A DOUBLE INTERMEDIATE BRACKET, 2 CONTROLS AT EACH END. ALLOWS INDEPENDENT CONTROL OF EACH BLIND. 	LEFT AND RIGHT on either blind	Y	Y

SPECIFICATIONS

Hardware - Double Roller Options

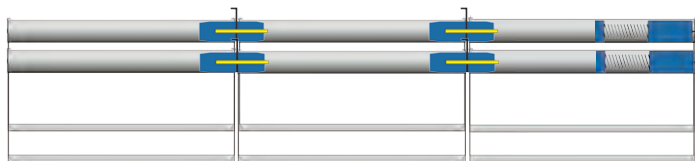
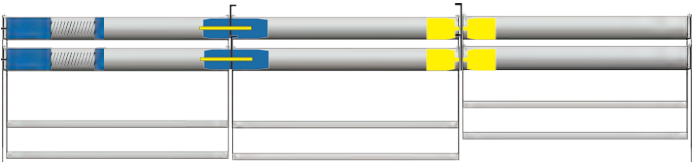
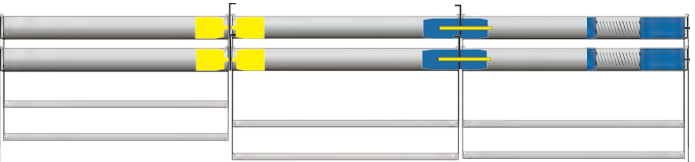
Description	Controls & Geared Clutch	Control Options		
		Motorised Y/N	Manual Y/N	
<p>3 DOUBLE ROLLER BLINDS LINKED TOGETHER WITH 2 DOUBLE MULTI BLIND UNIVERSAL BRACKETS & 2 GEARED CLUTCH. CONTROLS AT OPPOSITE ENDS WITH GEARED CLUTCH. ALLOWS 3 BLINDS TO BE RAISED TOGETHER.</p> 	LEFT AND RIGHT	Y	Y	
<p>3 DOUBLE ROLLER BLINDS LINKED TOGETHER WITH 2 DOUBLE MULTI BLIND UNIVERSAL BRACKETS & 2 GEARED CLUTCH. CONTROLS AT SAME END WITH GEARED CLUTCH. ALLOWS 3 BLINDS TO BE RAISED TOGETHER.</p> 	LEFT OR RIGHT	Y	Y	
<p>3 DOUBLE ROLLER BLINDS LINKED TOGETHER WITH 1 INTERMEDIATE BRACKET, 1 MULTI BLIND UNIVERSAL BRACKET, 2 GEARED CLUTCH & 2 CONTROLS. ALLOWS 2 DOUBLE BLINDS TO OPERATE TOGETHER AND 1 INDEPENDENTLY.</p> 	LEFT OR RIGHT on either blind	LEFT	Y	Y
<p>3 DOUBLE ROLLER BLINDS LINKED TOGETHER WITH 1 INTERMEDIATE BRACKET, 1 MULTI BLIND UNIVERSAL BRACKET, 2 GEARED CLUTCH & 2 CONTROLS. ALLOWS 2 DOUBLE BLINDS TO OPERATE TOGETHER AND 1 INDEPENDENTLY.</p> 	LEFT OR RIGHT on either blind	RIGHT	Y	Y

Note:



A Geared Clutch is not required on Roller Blinds when motorisation has been selected.



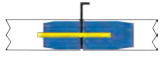

Light Gaps - Manual Operation with 50mm Tube

(with or without fascia system)

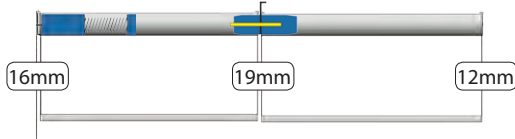
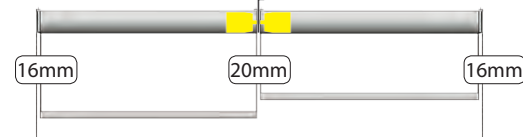

Key

Intermediate Bracket Allows blinds to operate independently 	Multi Blind Universal Bracket Allows up to 3 blinds to operate together 	Geared Clutch Allows blinds to be raised with less effort 
--	--	---

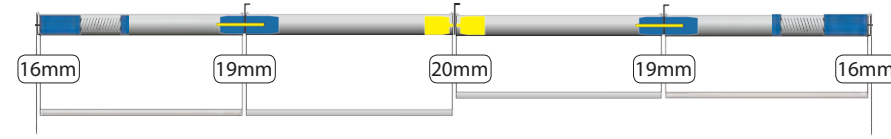
Description	Controls	Spring Assist
SINGLE CHAIN CONTROL ROLLER BLIND 	LEFT OR RIGHT	
2 ROLLERS LINKED TOGETHER WITH A MULTI BLIND UNIVERSAL BRACKET & 1 GEARED CLUTCH. 	LEFT OR RIGHT	
2 ROLLERS LINKED TOGETHER WITH AN INTERMEDIATE BRACKET. ALLOWS FOR INDIVIDUAL CONTROL. 	LEFT OR RIGHT on either blind	
3 ROLLERS LINKED TOGETHER WITH 2 MULTI BLIND UNIVERSAL BRACKETS, 1 CONTROL & 1 GEARED CLUTCH. ALLOWS 3 BLINDS TO BE RAISED TOGETHER. 	LEFT OR RIGHT	LEFT OR RIGHT
3 ROLLERS LINKED TOGETHER WITH 1 INTERMEDIATE BRACKET, 1 MULTI BLIND UNIVERSAL BRACKET, 1 GEARED CLUTCH & 2 CONTROLS. ALLOWS 2 BLINDS TO BE RAISED TOGETHER AND 1 INDEPENDENTLY. 	LEFT OR RIGHT on either blind	RIGHT
3 ROLLERS LINKED TOGETHER WITH 1 INTERMEDIATE BRACKET, 1 MULTI BLIND UNIVERSAL BRACKET, 1 GEARED CLUTCH & 2 CONTROLS. ALLOWS 2 BLINDS TO BE RAISED TOGETHER AND 1 INDEPENDENTLY. 	LEFT OR RIGHT on either blind	LEFT
4 ROLLERS LINKED TOGETHER WITH 2 GEARED CLUTCH, 2 MULTI BLIND UNIVERSAL BRACKETS, 1 INTERMEDIATE BRACKET. ALLOWS 2 SETS OF 2 BLINDS TO BE RAISED INDEPENDENTLY. 	LEFT AND RIGHT on either blind	LEFT OR RIGHT

Please Note: The light gap measurements are nominal based on 50mm tube.

SPECIFICATIONS

Sec. : Roller
 Date : Apr 2024
 Page: 18







Light Gaps - Motorised with 50mm Tube

(battery/240v wired)
(with or without fascia system)

SPECIFICATIONS

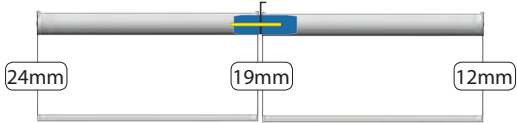
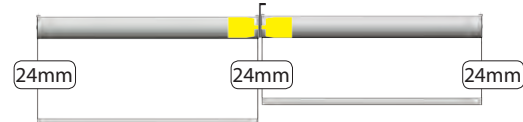
Key

Intermediate Bracket Allows blinds to operate independently	Multi Blind Universal Bracket Allows up to 3 blinds to operate together
---	---

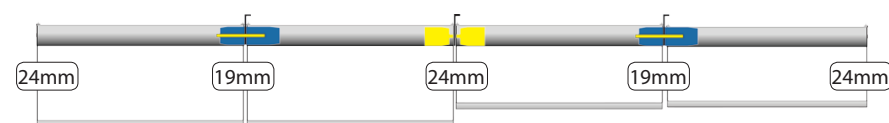
Description
SINGLE ROLLER BLIND (1 motor required) 
2 ROLLERS LINKED TOGETHER WITH A MULTI BLIND UNIVERSAL BRACKET (1 motor required). 
2 ROLLERS LINKED TOGETHER WITH AN INTERMEDIATE BRACKET. ALLOWS FOR INDIVIDUAL CONTROL (2 motors required). 
3 ROLLERS LINKED TOGETHER WITH 2 MULTI BLIND UNIVERSAL BRACKETS. ALLOWS 3 BLINDS TO BE RAISED TOGETHER (1 motor required). 
3 ROLLERS LINKED TOGETHER WITH 1 INTERMEDIATE BRACKET, 1 MULTI BLIND UNIVERSAL BRACKET. ALLOWS 2 BLINDS TO BE RAISED TOGETHER AND 1 INDEPENDENTLY (2 motors required). 
3 ROLLERS LINKED TOGETHER WITH 1 INTERMEDIATE BRACKET, 1 MULTI BLIND UNIVERSAL BRACKET. ALLOWS 2 BLINDS TO BE RAISED TOGETHER AND 1 INDEPENDENTLY (2 motors required). 
4 ROLLERS LINKED TOGETHER WITH 2 MULTI BLIND UNIVERSAL BRACKETS, 1 INTERMEDIATE BRACKET. ALLOWS 2 SETS OF 2 BLINDS TO BE RAISED INDEPENDENTLY (2 motors required). 

Please Note: The light gap measurements are nominal based on our 50mm tube.

Fascia System

Fascia System

The roller blind head-rail is available with a square no-notch Fascia for improved appearance and reduction in light gaps. The sleek design provides the most versatile technology available. Its durable elegance offers robust hardware with clean aesthetics and accommodates Single or Double Roller blinds. Square or Double Fascia systems accommodate manual or motorised options.



Double Roller Blind Fascia

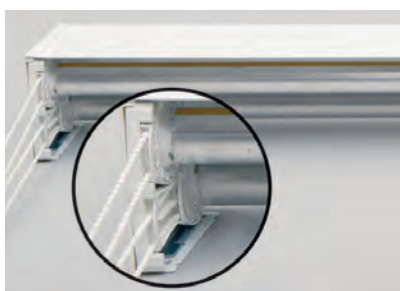

Single Square Fascia

Fascia Specification

Fascias are made of extruded aluminium (alloy/hardness 6063/T5) up to 4700mm long, with an average thickness of 1.5mm. Fascia Panels are finished with an electrostatically applied, baked on powder coating or clear natural anodised finish. The maximum overall width of a fascia system blind/s is 4700mm.

* Single fascia - fabric to be back rolled only.

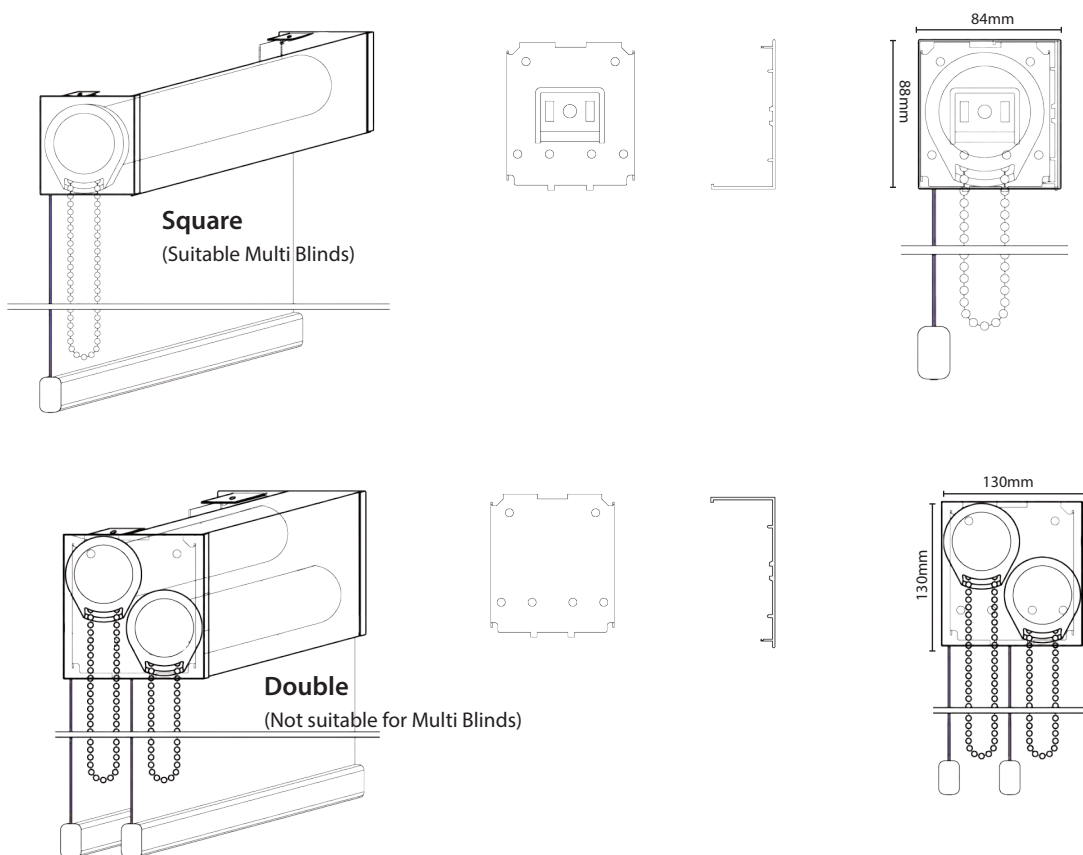

SPECIFICATIONS



Introduction to Fabric

SPECIFICATIONS

Introduction to Fabric

Fabric Overview:

The Window Treatments range of roller blind fabrics offers endless opportunities when used in commercial or domestic internal applications. We have various fabrics which comprise of intelligent energy saving screen fabrics, ecologically friendly, fire retardant, PVC free, mould and mildew resistant, light filtering to block-out fabrics.

Sunscreen:

Sunscreen fabrics can achieve significant reductions in the demand for air conditioning, reducing electricity consumption and greenhouse gas emissions. The Techno Screen range is very cost effective and works well in both commercial and domestic situations. Techno Screen is dimensionally stable and comes in a wide range of colours in 5%, 3% and 1% openness. PVC free Alu-Tech S2 (metalized backing) fabric is mostly used in commercial settings where a higher performance level is required in terms of heat, glare and fire retardancy. Alu-Tech S2 fabric is an independently certified "Cradle to Cradle Certified™ Bronze" by Cradle to Cradle Products Innovation Institute and is produced in Europe in a wide range of colours with most available ex our Christchurch factory and all fabrics are PVC free. The Cradle to Cradle Certified™ Material Health Assessment Methodology is a contextual assessment based on chemical hazard identification and qualitative exposure considerations during a product's final manufacture, use, and end-of-use.

Light-filtering Fabrics:

Our light-filtering fabrics provide more privacy than screen fabrics but still allow you to enjoy ambient light. The lighter the fabric colour the more ambient light you will achieve in the room. 100% polyester and acrylic coated, the Serengetti and Filtra ranges are also PVC Free.

Block-out Fabrics:

We carry an extensive range of block-out fabrics, some with a textured finish and others with foam or white flocked acrylic backing. These fabrics are ideally suited for computer rooms, offices, home theatre and bedrooms as they prevent glare and provide complete block-out when required. Most of our block-out fabrics are PVC free and all are resistant to mould and fungi, making block-out blinds ideal for installations in areas of high humidity and moisture.

Type/Name	Composition	Fire Retardant	Openness
SUNSCREEN			
Techno 2000 22	25% Polyester, 75% PVC	Yes	2%
Techno 5000 22	25% Polyester, 75% PVC	Yes	5%
Techno 10,000 22	25% Polyester, 75% PVC	Yes	10%
Alu-Tech S2	100% Polyester, (PVC Free)	Yes	3%
Enviroshade	100% Trevira-CS (PVC Free)	Yes	4-6%
Enviroshade Aluminium	100% Trevira-CS (PVC Free)	Yes	4-6%
LIGHT- FILTERING			
Serengetti	100% Polyester (PVC Free)	No	N/A
New Filtra	100% Polyester (PVC Free)	No	N/A
Jersey	100% Polyester (PVC Free)	No	N/A
Balmoral	100% Polyester (PVC Free)	Yes	3-5%
BLOCKOUT			
Serengetti	100% Polyester, (PVC Free)	No	N/A
Cardrona	100% Polyester, Acrylic Coated, PVC Free	No	N/A
Valencia	100% Polyester, Acrylic Coated, PVC Free	No	N/A
New Valencia	100% Polyester (PVC Free)	No	N/A
New Valencia FR	100% Polyester, Acrylic Coated, PVC Free	Yes	N/A
New Oxford	100% Polyester (PVC Free)	No	N/A
New Oxford Premium FR	100% Polyester (PVC Free)	Yes	N/A
Firenze	100% Polyester, Acrylic Coated, PVC Free	No	N/A
Balmoral	100% Polyester, PVC Free	No	N/A
Jersey	100% Polyester (PVC Free)	No	N/A
Gala	100% Polyester (PVC Free)	No	N/A
Waterfall	100% Polyester (PVC Free)	No	N/A

Somfy® Roller Blind Motorisation

- Wired

Window Treatments offers three wired motors capable of lifting up 19.6kg. Hardwired motors are always preferable, although Somfy battery blinds are available when hardwiring is not possible so it is important particularly for new builds that pre-wiring should be considered for any automation requirements.

Any blind on an 83mm tube requires an Altus 6/17 motor

Total Opening Width		50mm Tube									63mm Tube		83mm Tube		Multi-link Blinds Only						
		560	1000	1250	1500	1750	2000	2250	2500	2750	3000	3500	4000	4500	5000	5500	6000	6500	7000	7500	8000
Drop	1250	Green										Blue		Green							
	1500	Green										Blue		Green							
	1750	Green										Blue		Green							
	2000	Green										Blue		Green							
	2250	Green										Blue		Blue		Green				Red	
	2500	Green										Blue		Blue		Blue		Red		Red	
	2750	Green										Blue		Blue		Blue		Red		Red	
	3000	Green										Blue		Blue		Blue		Red		Red	
	3500	Green										Blue		Blue		Blue		Red		Red	

Key	Motor Type	Tube	Lifting Capacity
	Sonesse 3/30 Motor	50mm/63mm Tube	9.6kg
	Sonesse 6/20 Motor	50mm/63mm Tube	19.6kg
	Altus 6/17 Motor	83mm Tube	14.5kg

Minimum/Maximum Sizes

Window Treatments can produce a single motorised roller up to 5000mm wide with a 2250mm drop. As the width decreases, a larger drop is possible. Multi-link blinds can be produced up to 8000mm wide with a 4000mm drop, however we recommend blinds with drops exceeding 3500mm are installed with wire guides.

Performances	Sonesse 3/30	Sonesse 6/20	Altus 6/17
Torque	3nm	6nm	6nm
Nominal Voltage	230v	230v	230v
Rated Current	0.44	0.55	0.45
Rated Power	95W	120W	90W
Speed	30RPM	20RPM	17 RPM
Thermal Protection	4 Min	4 Min	4 Min
Radio Frequency	433.42	433.42	433.42
Sound Level (DB)	42	45	47
Cable Length	2500mm	2500mm	3000mm
IP Rating	IP 44	IP 44	IP 44
Insulation Class	II	II	I

Remote options

Hardwired and RTS (Radio Technology Somfy®) options are available. Hardwired; a maximum of five blinds or five groups of blinds can be controlled through a wall mounted remote. RTS allows for up to sixteen blinds or sixteen groups of blinds to be controlled wirelessly.



Situ 1 Remote



Situ 2 Remote



Situ 5 Remote



Telis 16 Channel



Telis 6 Chronis



Smoove Origin



Inis UNO



Inis DUO



Decoflex 5 Channel



SPECIFICATIONS



Somfy® Roller Blind Motorisation

- Wiring - Inline Connector & Flush Connector Housing

SPECIFICATIONS

To provide power to Somfy's wired motors, Window Treatments uses an Inline Connector and when requested, conceals the Inline Connector inside a Flush Connector Housing. The RTS Inline Connector has a two core cable while the non-RTS Inline Connector has a three core cable. This allows rewiring from a Non-RTS control to a RTS control

Below are wiring diagrams for both options:

RTS Inline Connector (Two Core Cable)

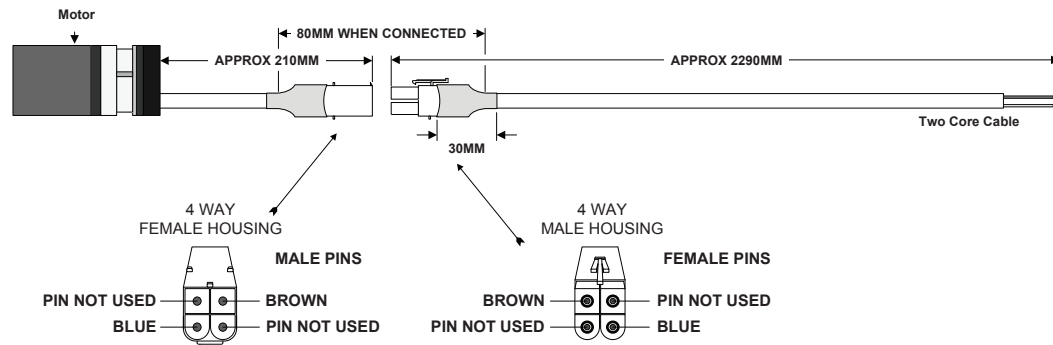

In-Line Connector and Housing Fitted

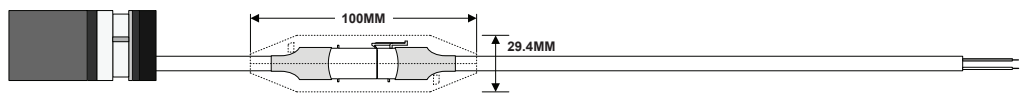

Non-RTS Inline Connector (Three Core Cable)

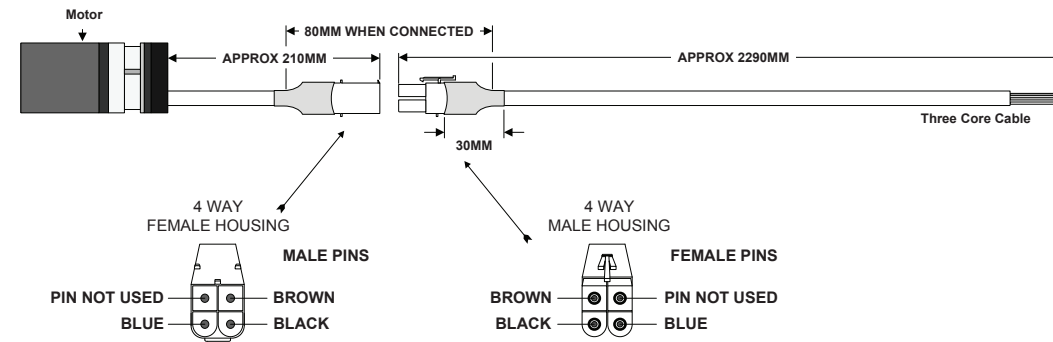

In-Line Connector and Housing Fitted

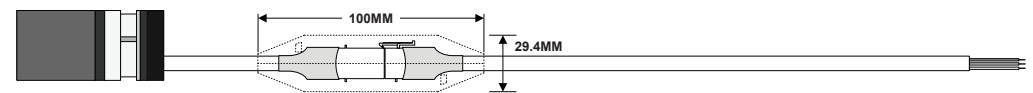

Flush Connector Housing

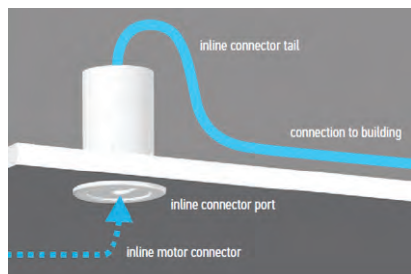

Technical Data	
Item Number	9026397
Item Description	Flush Connector Housing
Size	67 x 22 x 25mm
Colour	White
Patented Design	Au Pat 2018100721

Somfy® Roller Blind Motorisation

- Electrical requirements

Example of connection and recess sizing for a Single Motorised Roller Blind

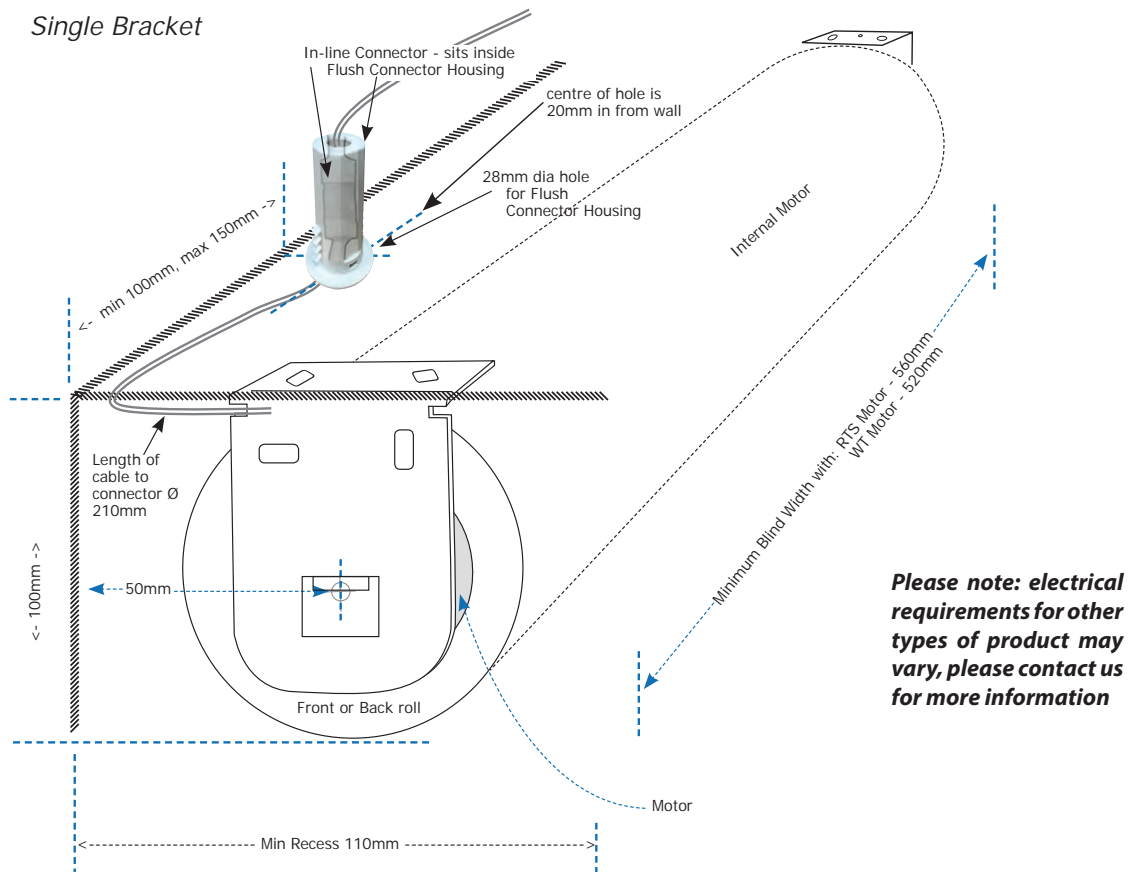

Power supply and A connection - incorrect wiring systems:

<p>Parallel Wiring</p> <p>Do not wire Somfy® standard motors in parallel. Each motor requires its own switch or relays. If group control is required contact us for the required controller and wiring information.</p>	<p>!! Do not wire motors in parallel !!</p>
<p>Multiple Switching</p> <p>Do not wire one motor directly to more than one switch. If multiple switching is required contact us for the required controller and wiring information.</p>	

SPECIFICATIONS



Somfy® Roller Blind Motorisation

- CONNEXOON

The Somfy® *Connexoon* app allows control of your motorised blinds via your smartphone devices whether you are at home or away. Scheduled time control allows automatic operation to help with light and heat control throughout the day. Each Connexoon can connect up to four smart devices allowing control of up to 30 Individual or 30 groups of RTS products. IFTTT compatible allows the ability to control via third party voice assistants including Google Home and Amazon Alexa.

Somfy® myLink Technical Characteristics	
Operating temperature	0°C to 45°C
Protection Rating	IP 30
Radio Frequency	RTS: 433.42 MHz
Radio Hz Range	200metres in open field, 20 metres through 2 reinforced concrete walls
Dimensions (H x W x D mm)	110 x 71 x 24 (without plug)



App for Phone & Tablet

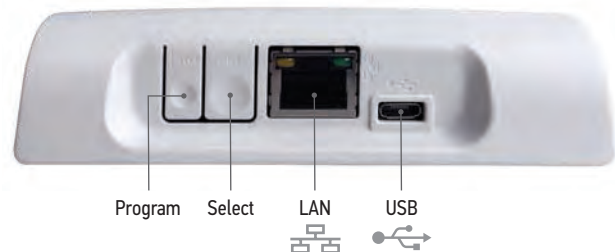

Please note: electrical requirements for other types of product may vary, please contact us for more information

It is important that your electrical professional is given the correct specifications and information at the wiring stage of construction therefore please arrange for your electrical professional to contact our Automation & Technician Specialist Acko Atkins with your project information.

Helpful information to have available when you ring or email is : Client name, your Window Treatments NZ Ltd Consultants name, product type and if possible the Window Treatments NZ Ltd Job Number.

**Acko Atkins - Automation & Technician Specialist,
Window Treatments NZ Ltd, Head Office
218 Main South Road, Christchurch,
Postal Address: P O Box 6260, Upper Riccarton, Chch 8442
Ph (03) 343 6175 DDI,
Mobile 027 439 8287,
Fax (03) 343 0277
Email acko.atkins@window-treatments.co.nz**

SPECIFICATIONS

Rollease Acmeda - Roller Blind Motorisation



Window Treatments offers three wirefree and wired motors capable of lifting up to 9.6kg. The Li-ion Battery powered motors are great for hard to reach places, especially when equipped with a solar panel. With the blinds being raised and lowered once a day, battery power will last approximately 3 months depending on fabric weight. A charging cable is provided and must be connected to the motor for 6 hours to provide optimum charge (standard 4mtr length supplied, 0.22mtr, 1.22mtr and 2.44mtr extensions available as optional extras). Alternatively, a solar panel charger can be fitted in the window to keep the motor charged allowing two cycles per day (once up and once down).

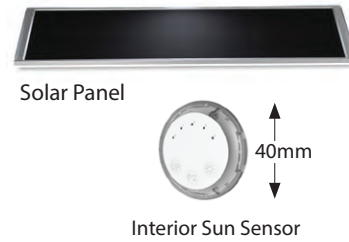

Minimum/Maximum Sizes

Window Treatments can produce a battery powered motorised roller blind to any size shown on the table. If your window is larger than our maximum size, our wired motorization offers more lifting capacity. Note: the minimum size for a wirefree multilink roller blind is 750mm.

Min - Max Blind Width for Li-ion Battery Motors

Drop	1 Blind 1 Motor 38/50mm Tube						1 Blind 1 Motor 50mm Tube				2 or 3 Blinds 1 Motor 50mm Tube						
	530	705	1000	1250	1500	1750	2000	2250	2500	2750	3000	3500	4000	4500	5000	5500	6000
1250																	
1500																	
1750																	
2000																	
2250																	
2500																	
2750																	
3000																	
3500																	

Key	Motor Type	Tube	Lifting Capacity
Yellow	1.1Nm Battery Motor	38mm/50mm Tube	3.6kg
Light Green	2.0Nm Battery Motor	50mm Tube	6.6kg
Dark Green	3.0Nm Battery Motor	50mm Tube	9.6kg
Black	6.0Nm Wired Motor	50mm Tube	24kg

Performances	Li-ion 1.1 Short Battery Motor	Li-ion 1.1 Battery Motor	Li-ion 2.0 Battery Motor	Li-ion 3.0 Battery Motor	Automate E6 Hardwired Motor	Automate M6 Hardwired Motor
Torque	1.1nm	1.1nm	2nm	3nm	6nm	6nm
Nominal Voltage	12v	12v	12v	12v	240v	240v
Rated Current (Amp)	0.96	0.96	1.25	0.83	0.85	0.85
Speed	20-24-28RPM	20-24-28RPM	20-24-28RPM	20-24-28RPM	33RPM	33RPM
Thermal Protection	12 Min	12 Min	12 Min	12 Min	4 Min	4 Min
Radio Frequency	433.92MHz	433.92MHz	433.92MHz	433.92MHz	433.92MHz	433.92MHz
Sound Level (DB)	46dB	46dB	46dB	53dB	44dB	44dB
IP Rating	IP 20	IP 20	IP20	IP 44	IP 44	IP 44
Insulation Class	III	III	III	III	III	III
Battery Size	1600mAH	2000mAH	2200mAH	5200mAH		

Compatibility Chart	Li-ion 1.1	Li-ion 2.0	Li-ion 3.0	Automate E6
Controller - Pulse	Y	Y	Y	Y
Controller - Paradigm	Y	Y	Y	Y
Sensor- Interior Sun Sensor	Y	Y	Y	Y
Sensor - Solar Wind & Light	-	-	-	-
Sensor Motion Sensor	-	-	-	-

Technologies

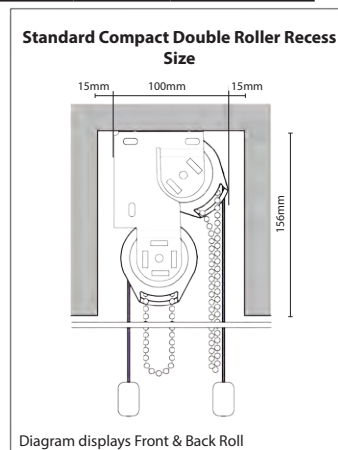
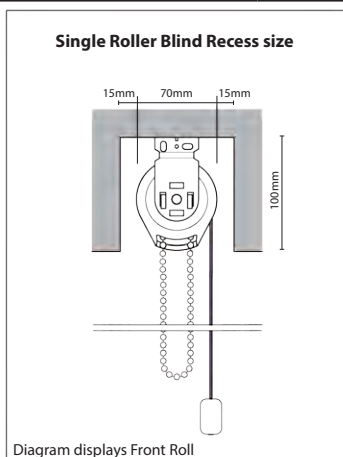
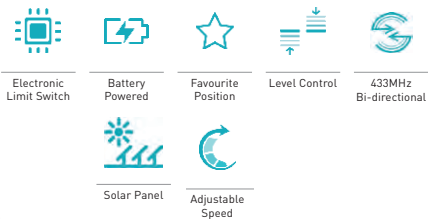

SPECIFICATIONS



RollEase® Acmeda - Roller Blind Motorisation

SPECIFICATIONS

To provide power to RollEase wired motors, Window Treatments uses an Inline Connector and when requested, conceals the Inline Connector inside a Flush Connector Housing. The RTS Inline Connector has a three core cable while the non-RTS Inline Connector has a four core cable. This allows rewiring from a non-RTS control to a RTS control

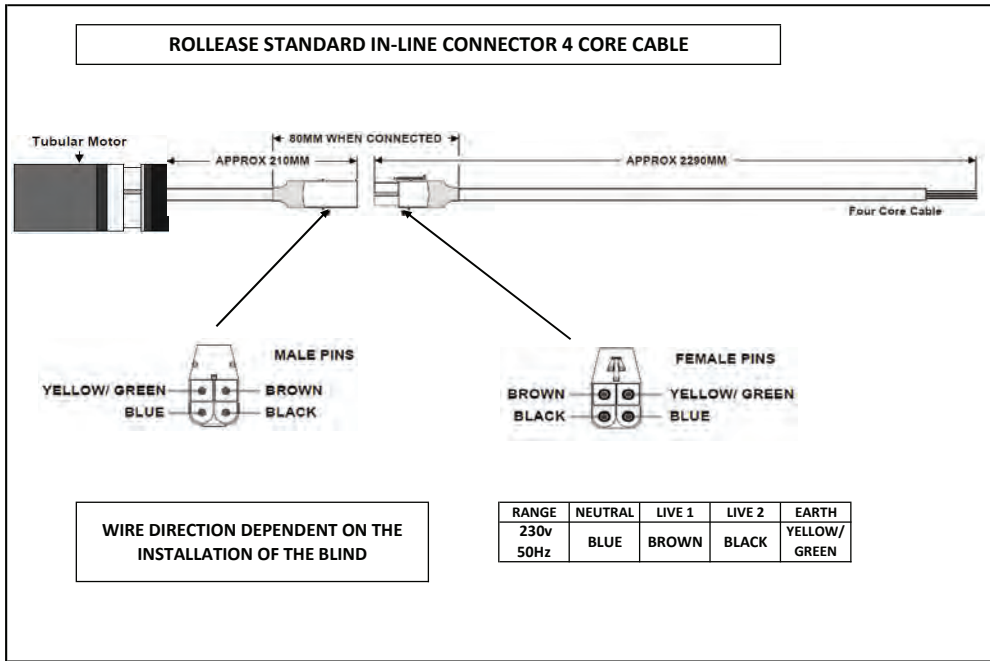
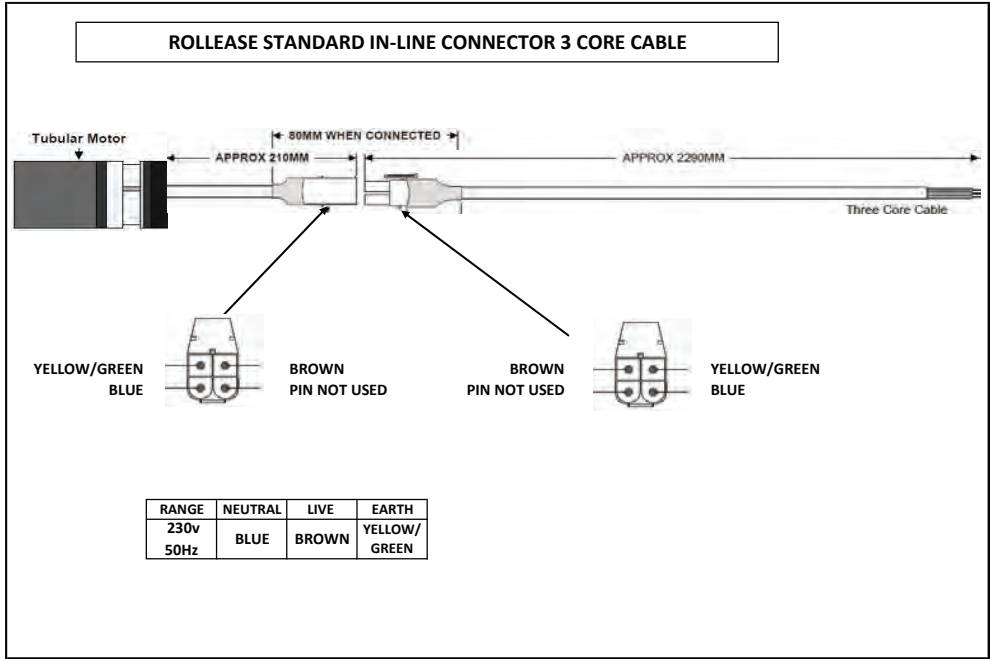

Flush Connector Housing

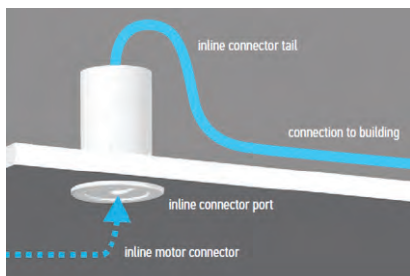

Technical Data	
Item Number	9026397
Item Description	Flush Connector Housing
Size	67 x 22 x 25mm
Colour	White
Patented Design	Au Pat 2018100721

RollEase® Acmeda - Roller Blind Motorisation

- Electrical requirements



Example of connection and recess sizing for a Single Motorised Roller Blind

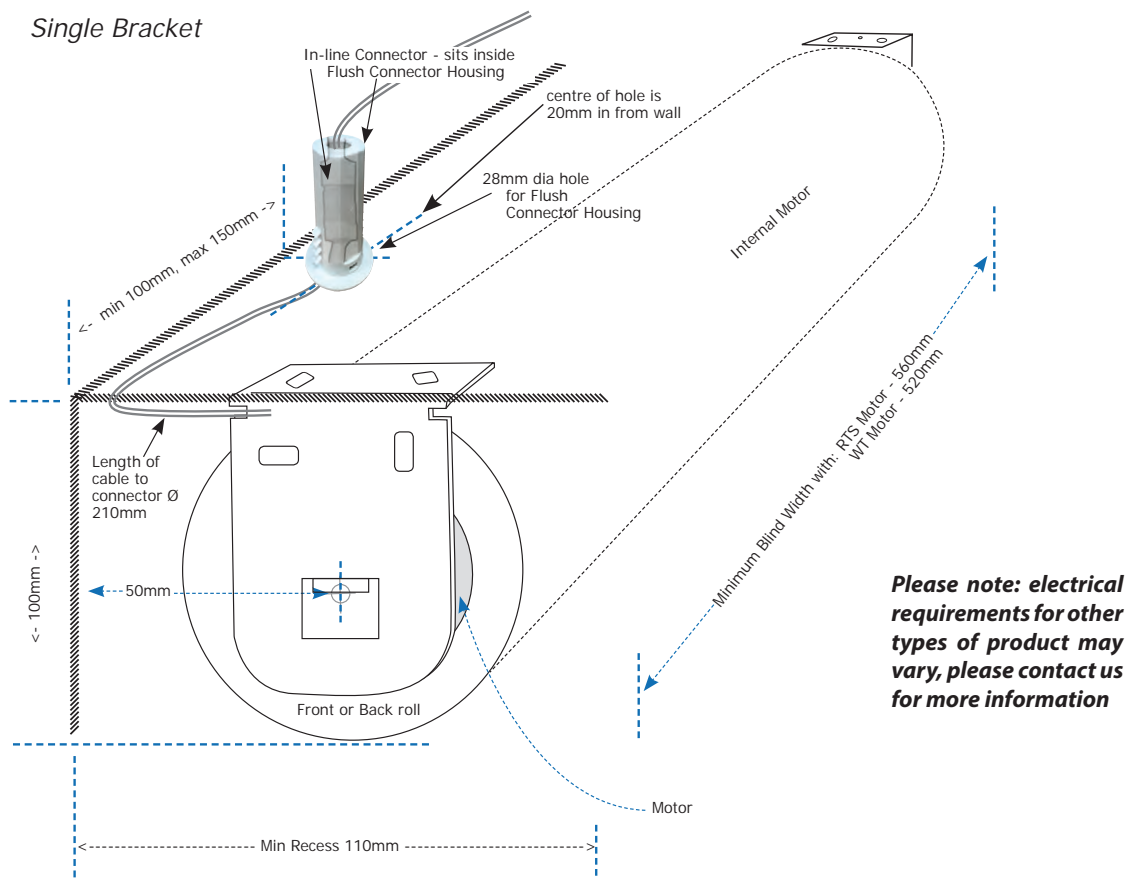

Power Options:

Parallel Wiring - Do not wire RollEase® standard motors in parallel. Each motor requires its own switch or relays. If group control is required contact us for the required controller and wiring information.

Multiple Switching Wiring - Do not wire one motor directly to more than one switch. If multiple switching is required contact us for the required controller and wiring information.

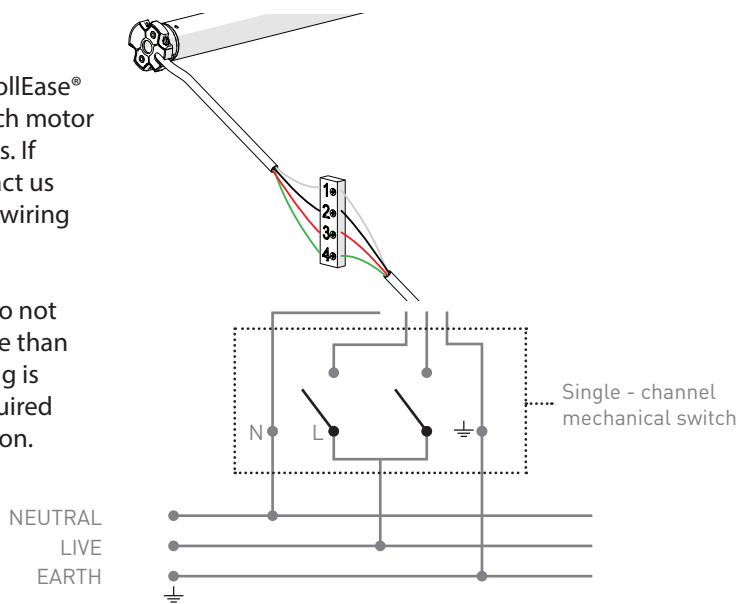

SPECIFICATIONS



Rollease Acmeda - Roller Blind Motorisation - Wirefree

SPECIFICATIONS

Control Options

Paradigm Remotes feature a contemporary design with touch sensitive controls. Available in single and fifteen channel models, paradigm remotes are compatible with all ARC motors. An LCD with levelling control features on the 15 channel remote, allowing for precise positioning of your blind.



Remote

Descr: Paradigm 5CH ARC Remote (5 Channel)

Automate Pulse/App

Whether you are at home or away, you can accurately control your blinds via the animated interface on your smart phone. Bi-directional communication allows you to visualise the exact positioning of blinds whilst also tracking the battery levels. Within the app, automate hub allows you to group shades into rooms making it easier to operate multiple blinds at once. Timers are also available allowing you to control sunlight throughout the day. This can help with heat loss/gain and provide UV protection to furnishings.

Automate Pulse Specifications		Automate Pulse Capabilities	
Installation	Desktop or wall mounted	Accounts per Hub	5 (1 admin, 4 guests)
Power Input	SVDC/1A	Locations per account	5
Rated Current	500mA	Devices per Hub	30
Rated Power	<2.5W	Hubs per location	5
Standby Power	≤300mA	Rooms per location	30
Wi-Fi Network	802.11 b/g/n - 2.4GHz only	Scenes per location	20
Device Central Frequency	433MHz	Timers per location	20
Radio Coverage	30m for device control (indoors)	Connection: Ethernet and Wifi	
Protection Class	IP20		
Antenna	Built-in		
Working Temperature	-10 ° to 45 °		
Storage Temperature	-20 ° to 55 °		

Automate Pulse 2 Hub



Solar Panel Charger

The Rollease Acmeda® solar panel charger is great for hard to reach places. The solar panel will allow you to raise and lower your blinds once a day whilst maintaining a constant charge to the motor. The mono-silicon/crystal solar panel provides power in varied conditions including in shadow-cast and low light situations. Panels can also be wired in parallel to provide additional power for larger applications.

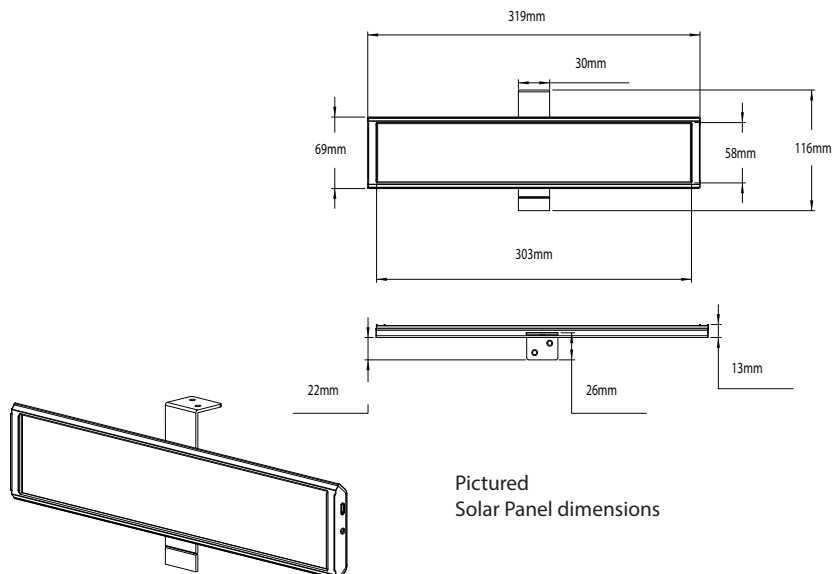



Blocco



Above: Blocco Roller Blind
Left: Blocco Honeycomb Blind

SPECIFICATIONS

Sec. : Blocco
Date : May 2021

Blocco Roller System - Overview



Blocco Roller System



Product Overview

Brand new to our stable of products is our Blocco Roller System. For the first time in New Zealand we can now offer this exclusive Blocco blind system. To achieve maximum light reduction, Blocco incorporates a fully enclosed cassette with side channels and bottom rail with a brush strip, all designed to minimise* light entering the room. The system is refined, compact and aesthetically pleasing and can be operated manually by a control chain or motorised with remote control or via a building management system.



*** In cases where windows are not 100% plumb or square our technicians will apply an additional brush strip to the outside edges of the side channel, cassette and bottom rail to help reduce light intrusion.**

Applications

Blocco Roller system is the perfect solution when maximum light reduction is required in commercial environments such as schools, hotels, hospitals and residential applications such as home theatre rooms and bedrooms.

Key Features

- Maximum light reduction design
- Full enclosed cassette and side channels
- Funnel side guides with brush which encapsulate fabric
- Chain control or motorised control, hard wired or wire free (battery) with remote or wall switch
- Brush under bottom rail to limit light intrusion
- The maximum* width for a single cassette can be up to 3000mm and maximum* drop up to 3000mm (*subject to fabric chosen). Note: total area (width x drop) can not exceed 6.5m²

Operation

- Manual - The control chain is supplied with either a plastic beaded chain (white or black) or nickel plated steel chain. Both options are looped inside a Control Chain Weight. The plastic beaded chain contains no risk of corrosion and runs more quietly when blind is raised or lowered.
Note: 1) If Chain-Stops are fitted to the chain to provide upper and lower limits, the chain length will be approximately the same as the window height.
2) If Chain-Stops are fitted to the chain as well as Control Chain Weights, the overall length of the chain and weight will be approximately 200mm longer than the window height.
- Motorisation - Can be automated via Somfy's range of Sonesse motors or RollEase® Automate motors. Control options includes hand held radio remote control, timers and sun sensors. Window Treatments NZ Ltd is an Authorised Somfy Automation Expert.

Finish

The Blocco aluminium cassette profile, side channels and bottom rail are available in black, white, anodised, ivory, silver pearl or bronze. Optional powder coated colours are available on request.

Fixing

Top Fit (inside window frame) or Face Fit (outside window frame).

Please note: Finished manufactured sizes are as follows:

- For an Top Fit (inside window frame), the finished width and finished drop will be 4mm less overall than the "wood to wood" measurements. For example an Inside Fit Blocco Roller blind W1000mm x D1500 (wood to wood), will be manufactured to a finished size of W996 x D1496.

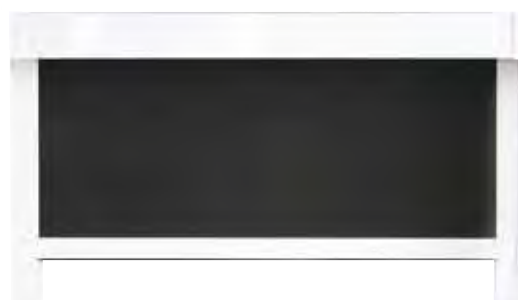

- For an Face Fit (outside window frame), the finished width and finished drop manufactured will be exactly the same as the measurements provided with no deductions. Example a Blocco Roller blind W1000mm x D1500 (wood to wood) will be manufactured to a finished size of W1000 x D1500.

SPECIFICATIONS

Sec. : Blocco
Date : May 2021

Blocco Roller System - Single Unit

SPECIFICATIONS

Blocco Single Unit - Technical Data

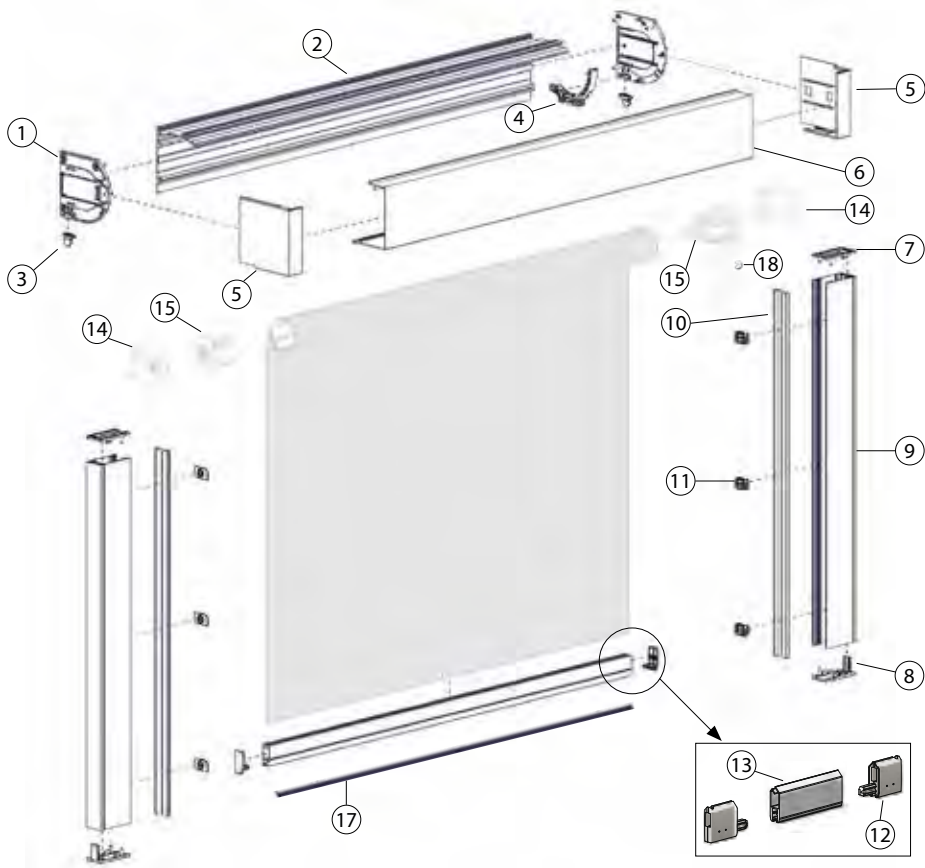
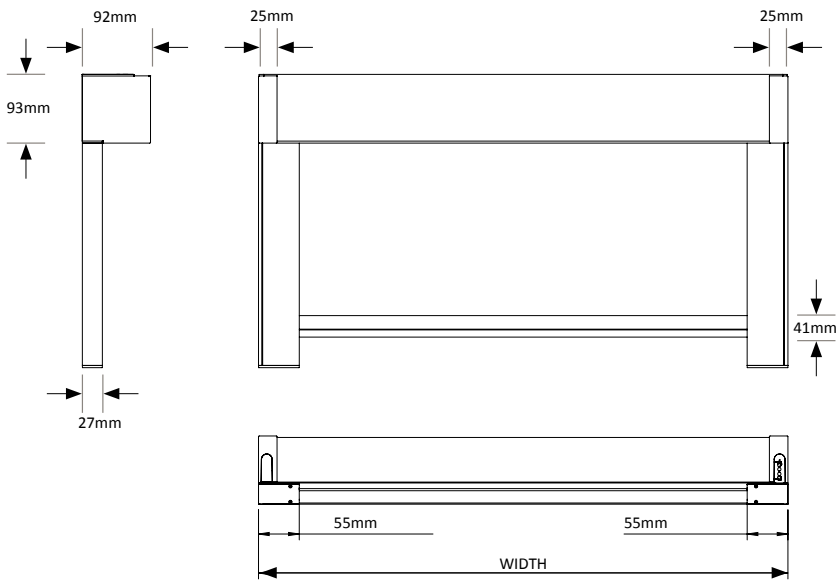

Key Numbers and Description

- | | |
|--------------------------|--------------------------|
| 1. End Plates | 11. Side Guide Lock |
| 2. Rear Cassette | 12. Bottom Rail Cap |
| 3. Side Guide Ear | 13. Bottom Rail |
| 4. Chain Guide | 14. Installation Bracket |
| 5. Cassette End Cap | 15. Control and Idler |
| 6. Front Cassette | 16. Tube |
| 7. Side Guide Funnel | 17. Bottom Rail Brush |
| 8. Side Guide Bottom Cap | 18. Chain Stop |
| 9. Side Guide (2 piece) | |
| 10. Side Guide Brush | |

Sec. : Blocco
Date: May 2021

Note: * In cases where windows are not 100% plumb or square our technicians will apply an additional brush strip to the outside edges of the side channel, cassette and bottom rail to help reduce light intrusion.

Introduction to Fabric



Introduction to Fabric

Fabric Overview:

The Window Treatments range of roller blind fabrics offers endless opportunities when used in commercial or domestic internal applications. We have various fabrics which comprise of intelligent energy saving screen fabrics, ecologically friendly, fire retardant, PVC free, mould and mildew resistant, light filtering to block-out fabrics.

Sunscreen:

Sunscreen fabrics can achieve significant reductions in the demand for air conditioning, reducing electricity consumption and greenhouse gas emissions. The Techno Screen range is very cost effective and works well in both commercial and domestic situations. Techno Screen is dimensionally stable and comes in a wide range of colours in 5%, 3% and 1% openness. PVC free Alu-Tech S2 (metalized backing) fabric is mostly used in commercial settings where a higher performance level is required in terms of heat, glare and fire retardancy. Alu-Tech S2 fabric is an independently certified "Cradle to Cradle Certified™ Bronze" by Cradle to Cradle Products Innovation Institute and is produced in Europe in a wide range of colours with most available ex our Christchurch factory and all fabrics are PVC free. The Cradle to Cradle Certified™ Material Health Assessment Methodology is a contextual assessment based on chemical hazard identification and qualitative exposure considerations during a product's final manufacture, use, and end-of-use.

Light-filtering Fabrics:

Our light-filtering fabrics provide more privacy than screen fabrics but still allow you to enjoy ambient light. The lighter the fabric colour the more ambient light you will achieve in the room. 100% polyester and acrylic coated, the Serengetti and Filtra ranges are also PVC Free.

Block-out Fabrics:

We carry an extensive range of block-out fabrics, some with a textured finish and others with foam or white flocked acrylic backing. These fabrics are ideally suited for computer rooms, offices, home theatre and bedrooms as they prevent glare and provide complete block-out when required. Most of our block-out fabrics are PVC free and all are resistant to mould and fungi, making block-out blinds ideal for installations in areas of high humidity and moisture.

Type/Name	Composition	Fire Retardant	Openness
SUNSCREEN			
Techno 5000	30% Polyester, 70% PVC	Yes	5%
Techno 3000W	30% Polyester, 70% PVC	Yes	3%
Techno 3000	30% Polyester, 70% PVC	Yes	3%
Techno 1000	30% Polyester, 70% PVC	Yes	1%
Techno Glass 5%	29% Fibreglass, 71% PVC	Yes	5%
Alu-Tech S2	100% Polyester, (PVC Free)	Yes	3%
Enviroshade	100% Trevira-CS (PVC Free)	Yes	4-6%
Enviroshade Aluminium	100% Trevira-CS (PVC Free)	Yes	4-6%
LIGHT- FILTERING			
Riviera	100% Polyester (PVC Free)	No	N/A
Serengetti	100% Polyester (PVC Free)	No	N/A
New Filtra	100% Polyester (PVC Free)	No	N/A
Jersey	100% Polyester (PVC Free)	No	N/A
Balmoral	100% Polyester (PVC Free)	Yes	3-5%
BLOCKOUT			
Riviera	100% Polyester, (PVC Free)	No	N/A
Serengetti	100% Polyester, (PVC Free)	No	N/A
Cardrona	100% Polyester, Acrylic Coated, PVC Free	No	N/A
Valencia	100% Polyester, Acrylic Coated, PVC Free	No	N/A
New Valencia	100% Polyester (PVC Free)	No	N/A
New Valencia FR	100% Polyester, Acrylic Coated, PVC Free	Yes	N/A
New Oxford	100% Polyester (PVC Free)	No	N/A
New Oxford Premium FR	100% Polyester (PVC Free)	Yes	N/A
Firenze	100% Polyester, Acrylic Coated, PVC Free	No	N/A
Balmoral	100% Polyester, PVC Free	No	N/A
Jersey	100% Polyester (PVC Free)	No	N/A
Gala	100% Polyester (PVC Free)	No	N/A
Addis	100% Polyester (PVC Free)	No	N/A

SPECIFICATIONS

Sec. : Blocco
Date : Jun 2021



Somfy® Blocco Roller Blind Motorisation - Wired & Wire Free

Window Treatments offers a Somfy wired motor capable of lifting up 9.6kg. Hardwired motors are always preferable, although Somfy battery blinds are available when hardwiring is not possible so it is important particularly for new builds that pre-wiring should be considered for any automation requirements.

Total Opening Width		Maximum sizes with Somfy Motorisation - S45 Tube									
		610	1000	1250	1500	1750	2000	2250	2500	2750	3000
Drop	1250										
	1500										
	1750										
	2000										
	2250										
	2500										
	2750										
	3000										

Contact Window Treatments for these sizes

Key	Motor Type	Tube	Lifting Capacity
	Somfy 1.5nm Battery	S45	6.0kg
	Somfy 2.0nm Battery	S45	8.0kg
	Sonesse 3/30 Motor	S45	9.6kg

Performances	Battery 1.5	Battery 2.0	Sonesse 3/30
Torque	1.5nm	2nm	3nm
Nominal Voltage	12 v	12v	230v
Rated Current	-	-	0.44
Rated Power	-	-	95W
Speed	10-20-28RPM	10-20-28RPM	30RPM
Thermal Protection			4 Min
Radio Frequency	433.42 MHz	433.42 MHz	433.42 MHz
Sond Level (DB)	54dB	44dB	42dB
Cable Length	-	-	2500mm
IP Rating	IP 20	IP 30	IP 44
Insulation Class	III	III	II

Remote options

Hardwired and RTS (Radio Technology Somfy®) options are available. Hardwired; a maximum of five blinds or five groups of blinds can be controlled through a wall mounted remote. RTS allows for up to sixteen blinds or sixteen groups of blinds to be controlled wirelessly.



Situo 1 Remote

Situo 2 Remote

Situo 5 Remote

Telis 16 Channel

Telis 6 Chronis

Smoove Origin



Inis UNO



Inis DUO



Decoflex 5 Channel



Sec. : Blocco
Date: May 2021

SPECIFICATIONS

Somfy® Blocco Roller Blind Motorisation

- Wiring - Inline Connector & Flush Connector Housing

To provide power to Somfy's wired motors, Window Treatments uses an Inline Connector and when requested, conceals the Inline Connector inside a Flush Connector Housing. The RTS Inline Connector has a two core cable while the non-RTS Inline Connector has a three core cable. This allows rewiring from a Non-RTS control to a RTS control

Below are wiring diagrams for both options:

RTS Inline Connector (Two Core Cable)

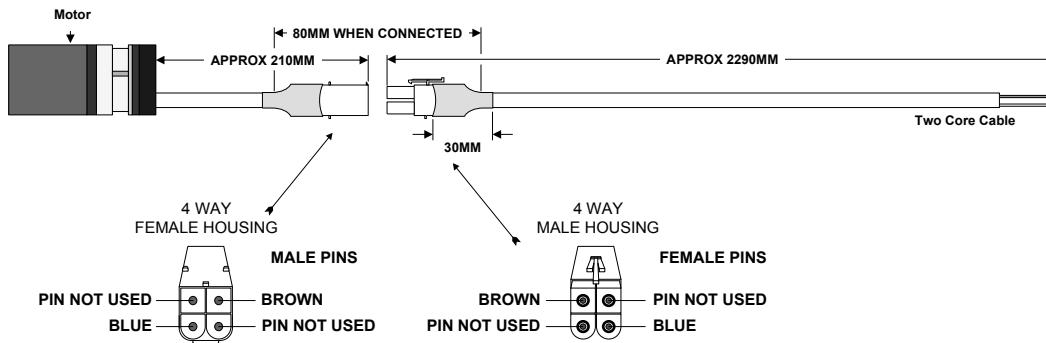

In-Line Connector and Housing Fitted

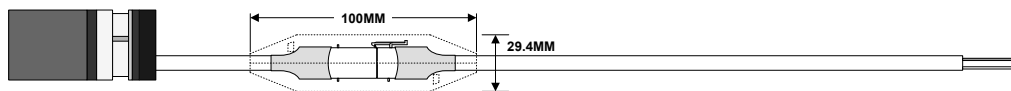

Non-RTS Inline Connector (Three Core Cable)

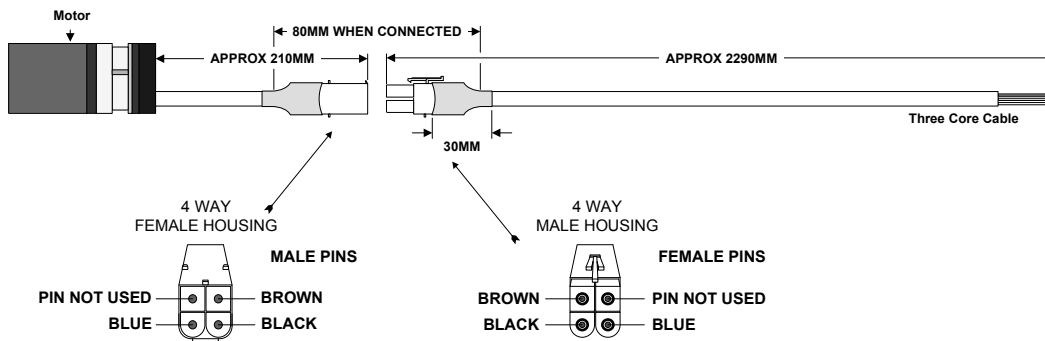

In-Line Connector and Housing Fitted

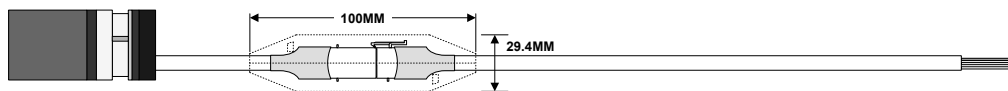

Flush Connector Housing

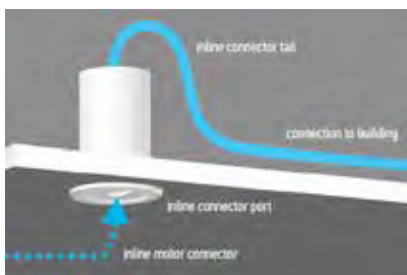

Technical Data	
Item Number	9026397
Item Description	Flush Connector Housing
Size	67 x 22 x 25mm
Colour	White
Patented Design	Au Pat 2018100721

Sec. : Blocco
Date : May 2021

SPECIFICATIONS

Somfy® Blocco Roller Blind Motorisation - Electrical requirements

Example of connection and recess sizing for a Single Motorised Roller Blind

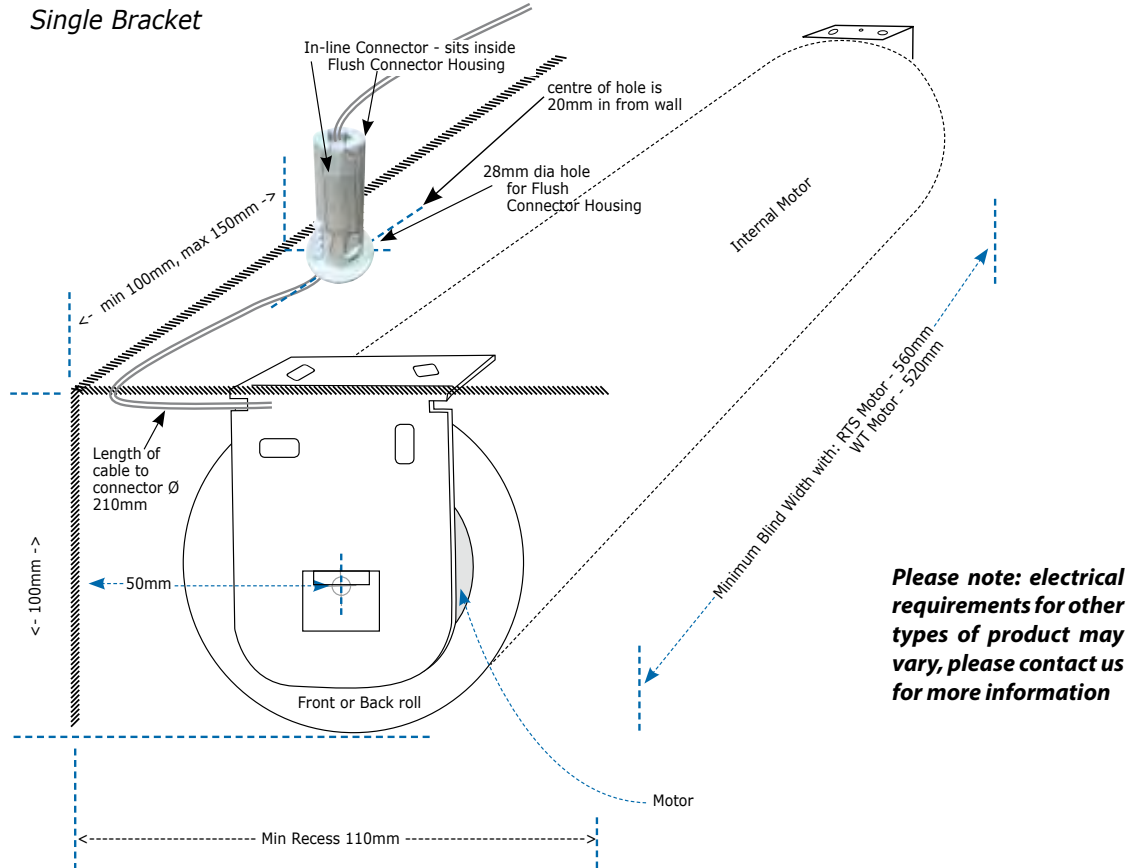

Power supply and A connection - incorrect wiring systems:

<p>Parallel Wiring</p> <p>Do not wire Somfy® standard motors in parallel. Each motor requires its own switch or relays. If group control is required contact us for the required controller and wiring information.</p>	<p>!! Do not wire motors in parallel !!</p>
<p>Multiple Switching</p> <p>Do not wire one motor directly to more than one switch. If multiple switching is required contact us for the required controller and wiring information.</p>	

Somfy® Blocco Roller Blind Motorisation - CONNEXOON

The Somfy® Connexoon app allows control of your motorised blinds via your smartphone devices whether you are at home or away. Scheduled time control allows automatic operation to help with light and heat control throughout the day. Each Connexoon can connect up to four smart devices allowing control of up to 30 Individual or 30 groups of RTS products. IFTTT compatible allows the ability to control via third party voice assistants including Google Home and Amazon Alexa.

Somfy® myLink Technical Characteristics	
Operating temperature	0°C to 45°C
Protection Rating	IP 30
Radio Frequency	RTS: 433.42 MHz
Radio Hz Range	200metres in open field, 20 metres through 2 reinforced concrete walls
Dimensions (H x W x D mm)	110 x 71 x 24 (without plug)

App for Phone & Tablet



Situo 1 Remote

Situo 2 Remote

Situo 5 Remote

Telis 16 Channel

Telis 6 Chronis

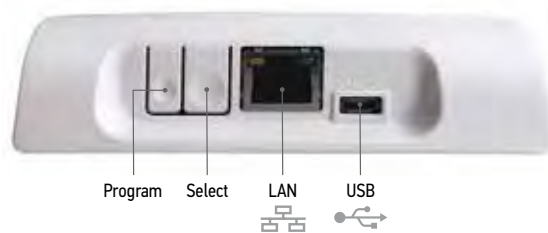

Program

Select

LAN

USB



Smoove Origin



Inis UNO



Inis DUO



Decoflex 5 Channel



Please note: electrical requirements for other types of product may vary, please contact us for more information

It is important that your electrical professional is given the correct specifications and information at the wiring stage of construction therefore please arrange for your electrical professional to contact our Automation & Technician Specialist Acko Atkins with your project information.

Helpful information to have available when you ring or email is : Client name, your Window Treatments NZ Ltd Consultants name, product type and if possible the Window Treatments NZ Ltd Job Number.

**Acko Atkins - Automation & Technician Specialist,
Window Treatments NZ Ltd, Head Office
218 Main South Road, Christchurch,
Postal Address: P O Box 6260, Upper Riccarton, Chch 8442
Ph (03) 343 6175 DDI,
Mobile 027 439 8287,
Fax (03) 343 0277
Email acko.atkins@window-treatments.co.nz**

Sec. : Blocco
Date : May 2021

SPECIFICATIONS



Rollease Acmeda Blocco Roller Blinds Motorisation - Wired & Wirefree

Window Treatments offers wirefree and wired RollEase Acmeda motors capable of lifting up to 9.6kg. The Li-ion Battery powered motors are great for hard to reach places, especially when equipped with a solar panel. With the blinds being raised and lowered once a day, battery power will last approximately 3 months depending on fabric weight. A charging cable is provided and must be connected to the motor for 6 hours to provide optimum charge (standard 4mtr length supplied, 1.22mtr and 2.44mtr extensions available as optional extras). Alternatively, a solar panel charger can be fitted in the window to keep the motor charged allowing two cycles per day (once up and once down).

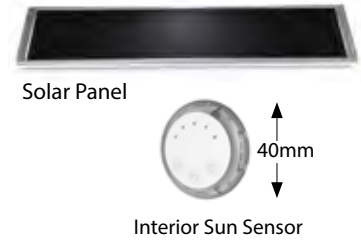

Minimum/Maximum Sizes

Window Treatments can produce a battery powered motorised roller blind to any size shown on the table. If your window is larger than our maximum size, our wired motorization offers more lifting capacity.

		Min -Max Blind Width for Li-ion Wirefree & Automate Hardwired Motors										
		610	740	1000	1250	1500	1750	2000	2250	2500	2750	3000
Drop	1250	[Grid of colored cells: Yellow for 1.1Nm Battery Motor, Green for 2.0Nm Battery Motor, Blue dashed for 6.0Nm Automate Hardwired]										
	1500											
	1750											
	2000											
	2250											
	2500											
	2750											
	3000											

Key	Motor Type	Tube	Lifting Capacity
[Yellow]	1.1Nm Battery Motor	S45	3.6kg
[Green]	2.0Nm Battery Motor	S45	6.6kg
[Blue dashed]	6.0Nm Automate Hardwired	S45	24kg

Performances	Li-ion 1.1 Battery Motor	Li-ion 2.0 Battery Motor	Automate E6 Hardwired motor	Automate M6 Hardwired motor
Torque	1.1nm	2nm	6nm	6nm
Nominal Voltage	12v	12v	240v	240v
Rated Current (Amp)	0.96	1.25	0.85	0.85
Speed	20-24-28RPM	20-24-28RPM	33RPM	33RPM
Thermal Protection	12 Min	12 Min	4 Min	4 Min
Radio Frequency	433.92MHz	433.92MHz	433.92MHz	433.92MHz
Sound Level (DB)	46dB	46dB	44dB	44dB
IP Rating	IP 20	IP20	IP 44	IP 44
Insulation Class	III	III	III	III
Battery Size	2000mAH	2200mAH		

Compatibility Chart	Li-ion 1.1	Li-ion 2.0	Automate E6
Controller - Pulse	Y	Y	Y
Controller - Paradigm	Y	Y	Y
Sensor- Interior Sun Sensor	Y	Y	Y
Sensor - Solar Wind & Light	-	-	-
Sensor Motion Sensor	-	-	-

Technologies

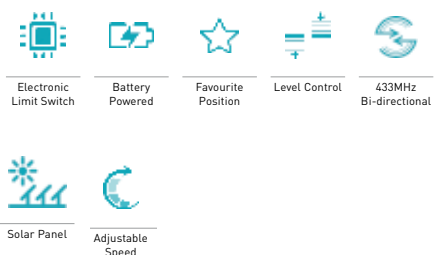

Sec. : Blocco
Date: May 2021

SPECIFICATIONS

RollEase® Acmeda

- Blocco Roller Blind Motorisation

To provide power to RollEase wired motors, Window Treatments uses an Inline Connector and when requested, conceals the Inline Connector inside a Flush Connector Housing. The RTS Inline Connector has a three core cable while the non-RTS Inline Connector has a four core cable. This allows rewiring from a non-RTS control to a RTS control

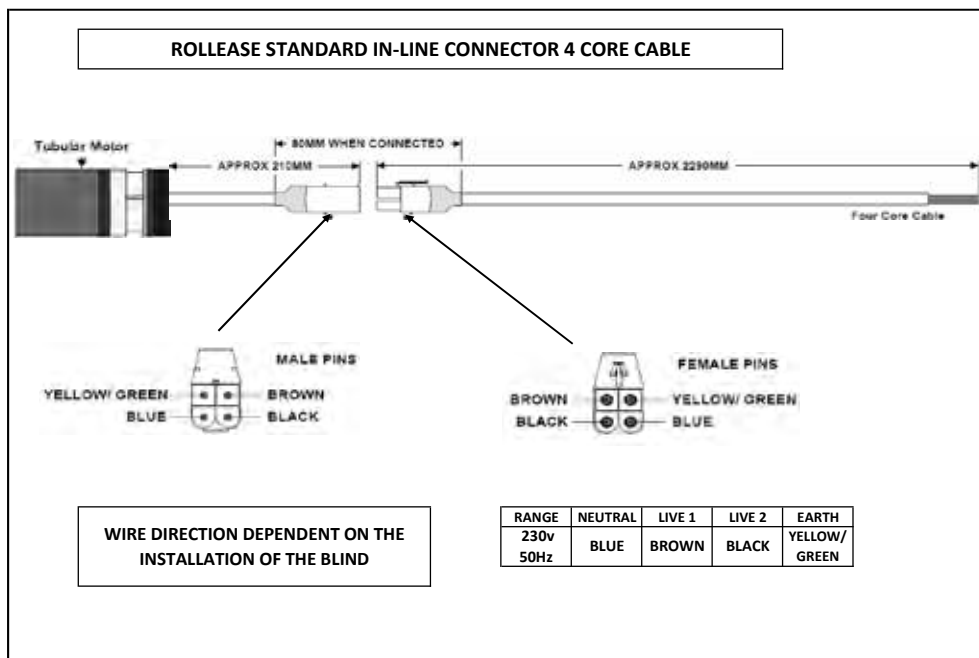
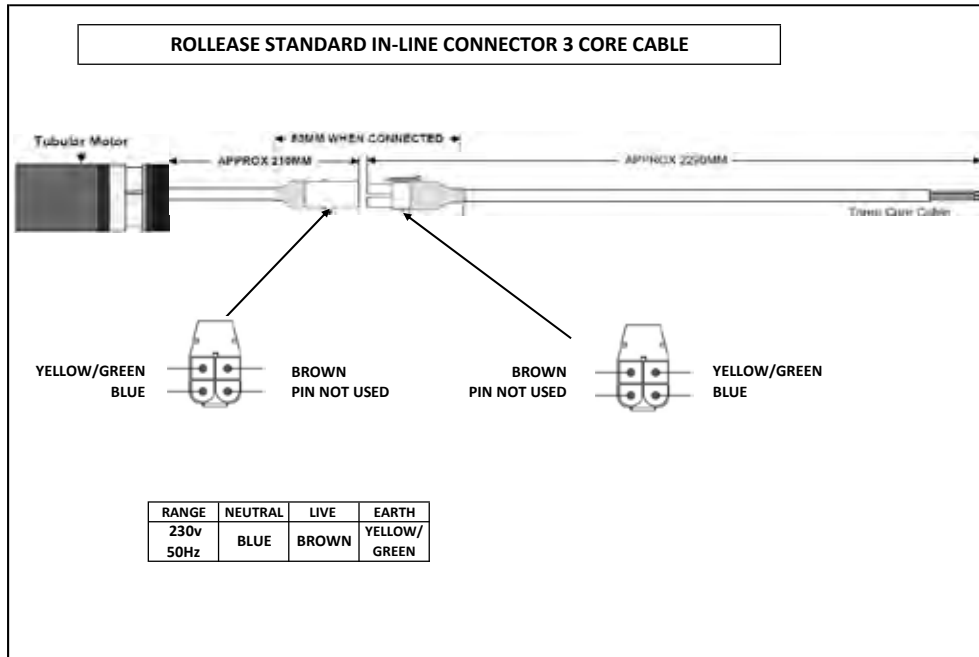

Flush Connector Housing

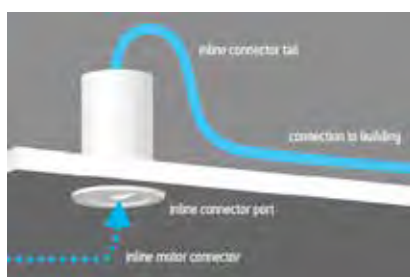

Technical Data	
Item Number	9026397
Item Description	Flush Connector Housing
Size	67 x 22 x 25mm
Colour	White
Patented Design	Au Pat 2018100721

Sec. : Blocco
Date: May 2021



RollEase® Acmeda

- Blocco Roller Blind Motorisation - Electrical requirements

Example of connection and recess sizing for a Single Motorised Blocco Roller Blind

Single Bracket

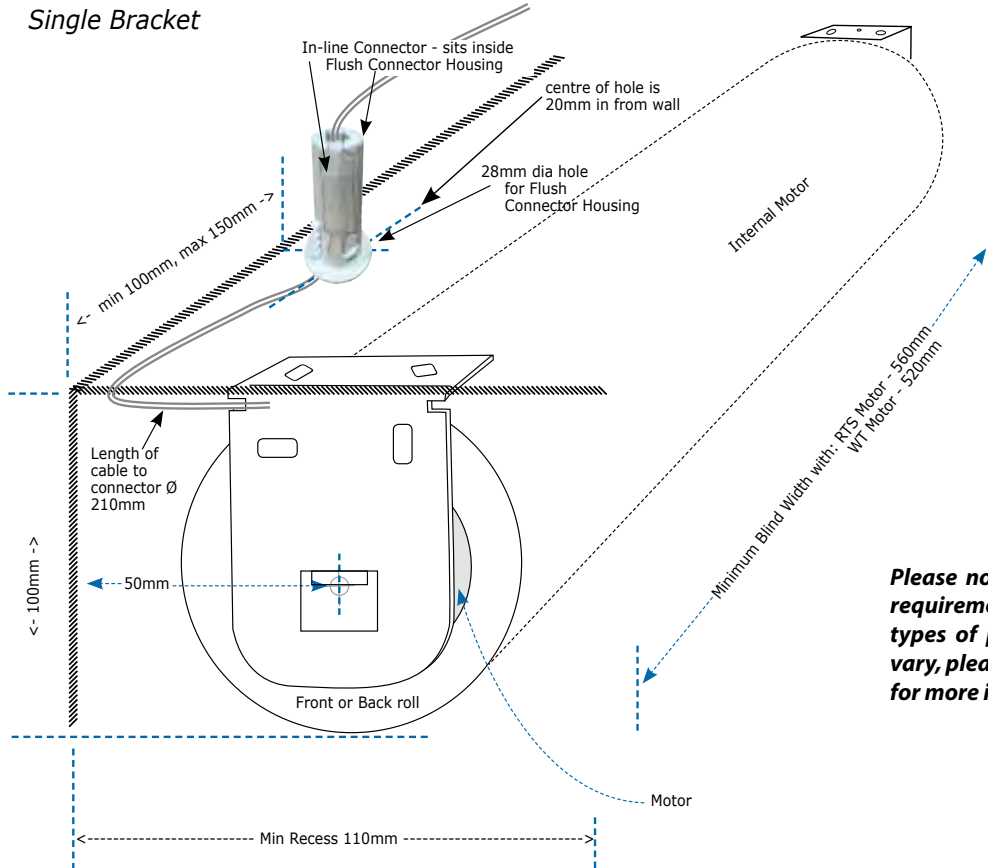

Please note: electrical requirements for other types of product may vary, please contact us for more information

Power Options:

Parallel Wiring - Do not wire RollEase® standard motors in parallel. Each motor requires its own switch or relays. If group control is required contact us for the required controller and wiring information.

Multiple Switching Wiring - Do not wire one motor directly to more than one switch. If multiple switching is required contact us for the required controller and wiring information.

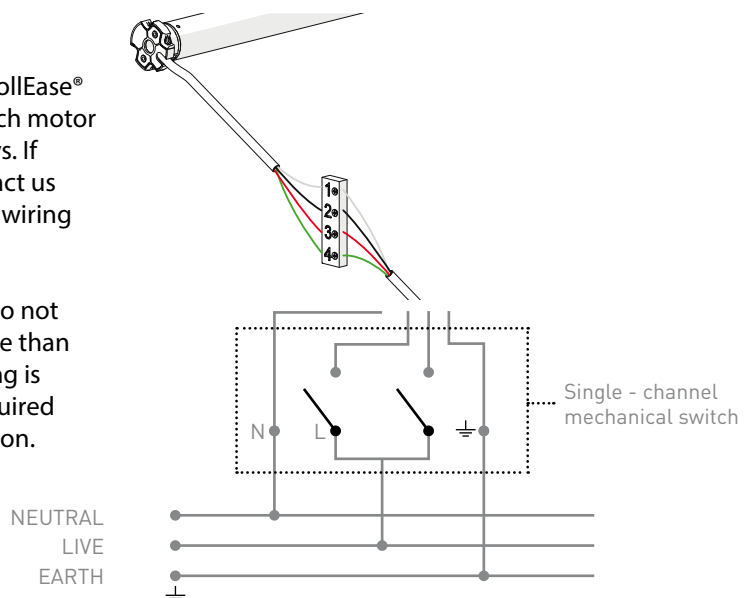

SPECIFICATIONS

Rollease Acmeda - Blocco Roller Blind Motorisation - Wired & Wirefree

Control Options

Paradigm Remotes feature a contemporary design with touch sensitive controls. Available in single and fifteen channel models, paradigm remotes are compatible with all ARC motors. An LCD with levelling control features on the 15 channel remote, allowing for precise positioning of your blind.



Remote

Descr: Paradigm 5CH ARC Remote (5 Channel)
Descr: Paradigm 15CH ARC Remote (15 Channel)

Automate Pulse/App

Whether you are at home or away, you can accurately control your blinds via the animated interface on your smart phone. Bi-directional communication allows you to visualise the exact positioning of blinds whilst also tracking the battery levels. Within the app, automate hub allows you to group shades into rooms making it easier to operate multiple blinds at once. Timers are also available allowing you to control sunlight throughout the day. This can help with heat loss/gain and provide UV protection to furnishings.

Automate Pulse Specifications		Automate Pulse Capabilities	
Installation	Desktop or wall mounted	Accounts per Hub	5 (1 admin, 4 guests)
Power Input	5VDC/1A	Locations per account	5
Rated Current	500mA	Devices per Hub	30
Rated Power	<2.5W	Hubs per location	5
Standby Power	≤300mA	Rooms per location	30
Wi-Fi Network	802.11 b/g/n - 2.4GHz only	Scenes per location	20
Device Central Frequency	433MHz	Timers per location	20
Radio Coverage	30m for device control (indoors)	Connection: Ethernet and Wifi	
Protection Class	IP20		
Antenna	Built-in		
Working Temperature	-10 ° to 45 °		
Storage Temperature	-20 ° to 55 °		

Automate Pulse 2 Hub



Solar Panel Charger

The Rollease Acmeda® solar panel charger is great for hard to reach places. The solar panel will allow you to raise and lower your blinds once a day whilst maintaining a constant charge to the motor. The mono-silicon/crystal solar panel provides power in varied conditions including in shadow-cast and low light situations. Panels can also be wired in parallel to provide additional power for larger applications.

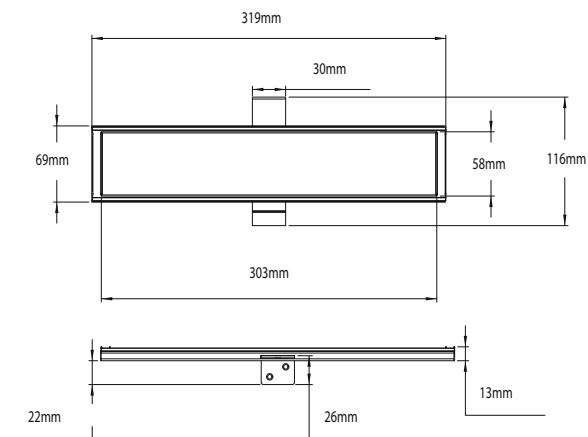
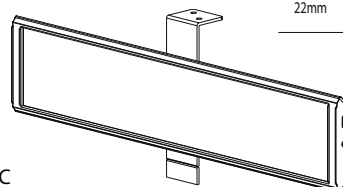

Pictured Solar Panel dimensions



Solar Panel

- Output voltage 12.6V
- Output power 2.73W
- Working Temperature: -20°C - 80°C
- Dimensions: 303mm x 58mm x 13mm

Sec. : Blocco
Date : May 2021

SPECIFICATIONS



SPECIFICATIONS

Blocco Honeycomb - Overview



Product Overview

Product Overview Blocco honeycomb blinds offer excellent insulation, an attractive combination of high fashion, good value, easy installation and convenient operation. Simply styled and designed, Honeycomb blinds are an economical option in soft window coverings. Choose from a selection of decorative block-out or light-filtering fabrics.

Whilst the Blocco Honeycomb Blind uses the same honeycomb fabric as pleated blinds, the Blocco hardware system is radically different to that of the more conventional honeycomb pleated blinds. The design of the hardware system differs because Blocco Honeycomb Blinds are often installed in roof or ceiling spaces where access and control of the blinds is very limited.

In the motorised option the raising and lowering of the blind is achieved with a rotating spool within the head rail which in turn is driven by a 12v internal motor.

The Blocco Honeycomb hardware system incorporates an entirely different raising and lowering design due to the fact that the blind must function normally irrespective of the angle the blind is installed at.

In addition to the unique functionality of the Blocco Honeycomb system the blind also incorporates a full four-sided channel frame which provides a light stop on both sides of the blind. This feature is particularly useful where total room darkening is required but also provides a very neat and tidy finish to the blind.

The raising and lowering of the blind is made possible with a looped belt drive inside both side channels which are simultaneously driven by the motor located in the headrail. The manual control option is visually identical to the motorised version. It has the same four-sided channel frame with a looped belt drive inside both side channels. The only difference to the motorised version is that the raising and lowering of the blind is carried out by connecting an extension pole onto the bottom rail. Due to the unique hardware design of the Blocco Honeycomb Blind, the blind can be installed at any angle whether it's perpendicular/vertical, horizontal or inclined making it the most versatile blind on the market.

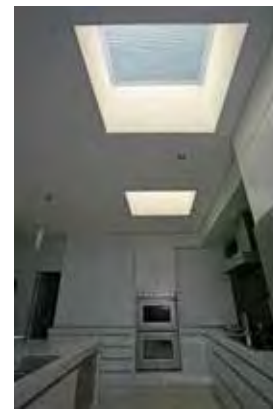

Control Options:

Motorisation: For windows that are out of reach such as conservatories or some commercial installations, Window Treatments can motorise your Honeycomb pleated blinds with a hard-wired Dooya 12v motor, or by an external rechargeable lithium battery. The raising and lowering of the blind is achieved with a rotating spool within the head rail which is driven by motor.

A small solar panel can also be connected to the battery pack to boost the operational life of the battery. The blinds can be operated by remote and/or integrated into a BMS system via a Dooya HUB.

Manual: Control by a push/pull pole with automatic braking at any position.

Aluminium side channels, head and bottom rail colours:

White, Ivory, Silver Pearl, Bronze, & Black.

Nylon frame corner : White, Black

Installation: Top fit or face fit mounting through the side channels or top and bottom rails. Light gaps are removed with a brush strip which is attached to the outside edge of blind frame. Blinds can be butted together to enable coverage of wide openings.

Please note: Finished manufactured sizes are as follows :

- For an Top Fit (inside window frame) , the finished width and finished drop will be 4mm less overall than the "wood to wood" measurements. For example an Inside Fit Blocco Honeycomb blind W1000mm x D1500 (wood to wood), will be manufactured to a finished size of W996 x D1496.
- For an Face Fit (outside window frame), the finished width and finished drop manufactured will be exactly the same as the measurements provided with no deductions. Example a Blocco Honeycomb blind W1000mm x D1500 (wood to wood) will be manufactured to a finished size of W1000 x D1500.



SPECIFICATIONS

Sec. : Blocco
Date : May 2021



Blocco Honeycomb

- Size Guidelines

SPECIFICATIONS

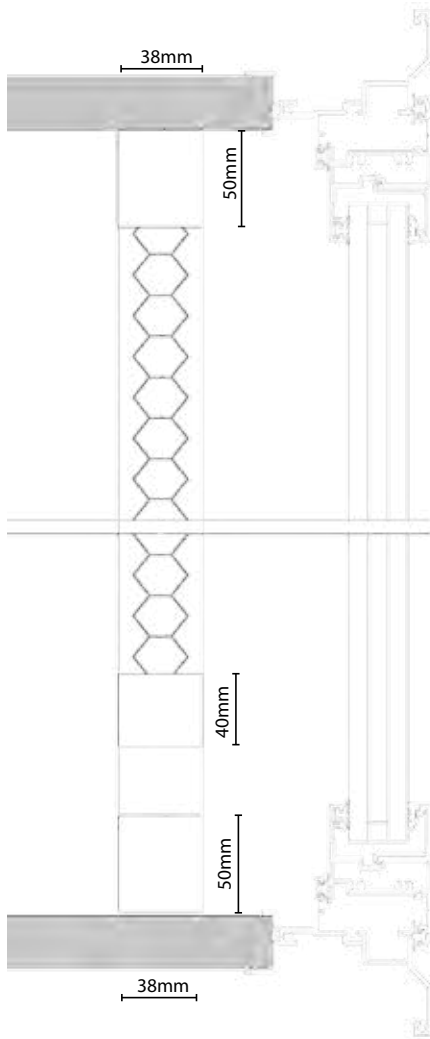

Recess Measurements: (side fit only)

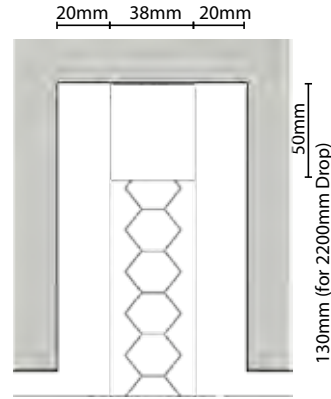

Multi Blind Installation

Maximum Size Guidelines for Block-out Fabric

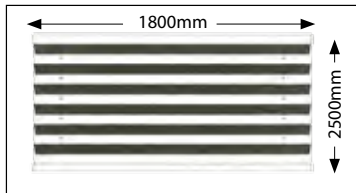

Maximum Size Guidelines for Sun Filtering

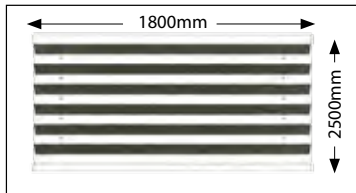

Skylight honeycomb
- fully retracted

Sec. : Blocco
Date: May 2021

Blocco Honeycomb Blind

- Motorisation options & Manual Control

Manual: Control by a push/pull pole with automatic braking at any position.

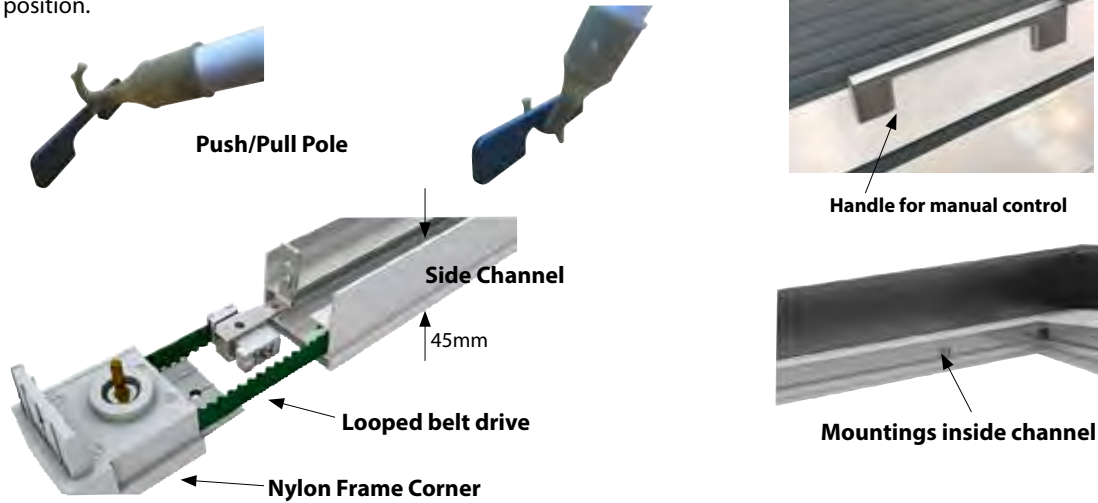

Motorised Operation:

For windows that are out of reach such as conservatories or some commercial installations, Window Treatments can motorise your Blocco Honeycomb blinds with a hard-wired Dooya 12v motor, or by an external rechargeable lithium battery. The raising and lowering of the blind is achieved with a rotating spool within the head rail which is driven by motor.

A small solar panel can also be connected to the battery pack to boost the operational life of the battery.

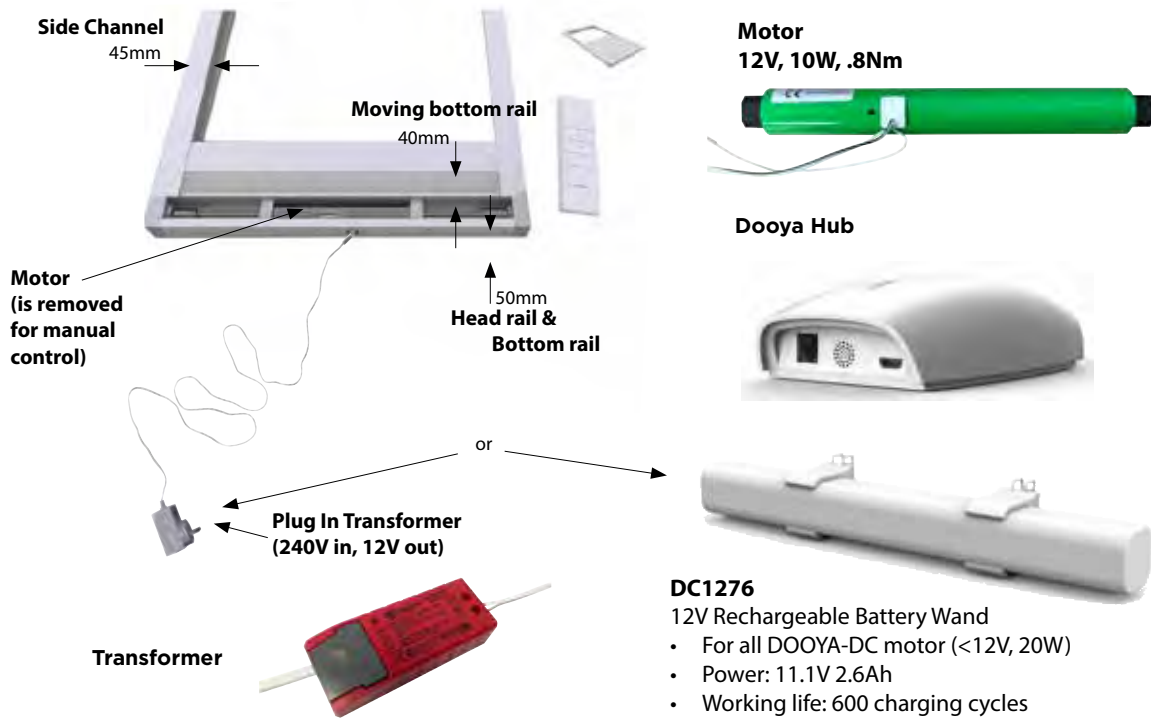

DC1276

- 12V Rechargeable Battery Wand
- For all DOOYA-DC motor (<12V, 20W)
 - Power: 11.1V 2.6Ah
 - Working life: 600 charging cycles
 - Dimension: 225mm x 27.5mm x 27.5mm

DC1289A

- Dooya Solar Panel
- Output voltage: 12.6V
 - Output power: 3W
 - Working Temperature: -20°C ~ + 80°C
 - Service life: 5 years
 - Dimension: 419mm x 54mm x 16mm

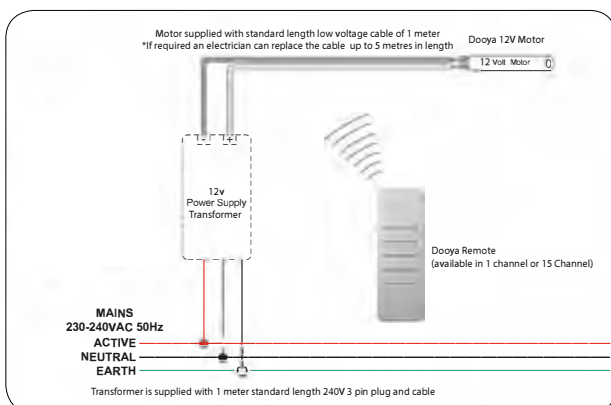

SPECIFICATIONS

Fabrics

A wide range of Honeycomb pleated blind fabrics are available in both block-out and light-filtering fabrics. A special feature of a honeycomb blind is that the cords on the blind are not visible as are fed through through the centre of the Honeycomb cells. Furthermore, both block-out and light-filtering honeycomb fabrics have superior heat retention due to the two layered cell construction. The Sonata range of light filtering fabrics create a soft focus in a stylish contemporary colour range. These fabrics gently filter sunlight, prevent UV damage and provide a flattering ambient light. Our block-out honeycomb fabrics which are 100% polyester non-woven are perfect for controlling light and offer complete privacy. If you prefer some natural light and still retain your heat our light-filtering honeycomb fabrics would provide a perfect solution.



Sonata Block-out and Light Filtering Overview

(recommended for both perpendicular windows and skylight windows)

The Sonata block-out Honeycomb range of 45 colours consists of 2 layers of fabric with a foil lined white backing. The deliberately chosen white rear ensures a uniform appearance to the outside and provides a high degree of light reflectivity. Both the inside and the outside have a subtle textile character. The foil core gives the fabric extra stability, a plus point with the extreme heat that often occurs with skylights. If you prefer some natural light and still retain your heat our Sonata light-filtering honeycomb fabric would provide a perfect solution.

TECHNICAL DATA	Block-out	Light-filtering
COMPOSITION	100% Polyester	100% Polyester
FABRIC THICKNESS	0.16mm	0.25mm
FABRIC WEIGHT	190 gsm	204 gsm
PLEAT HEIGHT	25mm (±0.5mm)	25mm (±0.5mm)
LIGHT FASTNESS	4	4
METALLIZED	Yes	No
BLOCKOUT	Yes	No

Sonata Block-out & Light-filtering (45 colours available)



PLEASE NOTE: Colours shown are indicative only. Fabric Samples are available on request.



Custom Made Curtains



**Left: Sheer Unlined & Sheer Lined curtains.
Top: Opaque Lined curtain
Above: Sheer Unlined curtain**

SPECIFICATIONS

Sec. : Curtains
Date : June
2024



Custom Made Curtains - Overview

Agdljefaf_ ž SVWljdFS[dš YW[UgVWeg` f W eZWVedWWS' UWS' V f W eZWWS' V ljdFS[designs which provide dim-out/T'au] žagf S' V add fZVM_ S' bcbWfVWz5gdFS[eTq[Y eaX' V eS' V eabZ[ef[LSf[a` fa S' k Vélacž AgdljdFS[eSdW_ SVM[@W LVŠS' Vi [fZ S' S^_ aefg` f [fW dš YWaxZ[YZ Xsz[a` fcgS'fk fVf[V eS' V La'agdež

Features of Custom Made Curtains for Domestic & Commercial applications include:

- A choice of stylish curtain pleats and gathering types
- Extensive design & colour range of fabric options which include but are not limited to:
 - Sheer, unlined curtains
 - Lined sheer curtains
 - Thermal lined curtains
 - Dim-out & Block-out curtains
 - Fire retardant curtains
 - Noise dampening curtains
- Custom made curtaining for residential and commercial areas - hotels, hospitality, businesses, offices, rest homes, hospitals
- Multiple fabric combinations to effortlessly control room light & privacy
- Smooth glided track system which can be hand drawn, cord drawn or motorised
- A tracking system that can be top, face or recessed mount
- Anti-ligature tracking systems
- Colour coordinated track & bracket covers
- Dim-out a bedroom with block-out or dim-out lined curtains
- Use double tracks with sheers to filter light during the day and a block-out curtain for night
- Roman blinds to match any décor
- Your options are near limitless

Introduction to fabrics:

Sheers as: Sheer Unlined Curtains

Visually 'light' they soften any space whilst filtering UV and protecting interior furnishings.

Available in:

Note: FR = Fire Retardant



Cavalier Sheers
26 colourways



Coastal Sheers FR
8 colourways



Antipodes Sheers
12 colourways



Martinique Sheers FR
11 colourways



Pilbara Sheers FR
12 colourways



Southport Sheers FR
32 colourways

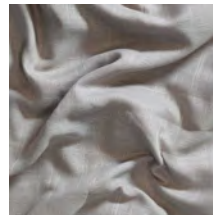

Easton Sheers FR
10 colourways



Sencha Sheers FR
9 colourways

Curtains (no lining required)

Room dimming fabric with block-out or triple weave as part of its construction does not need further lining fabric. Available in:



Halifax Blockout
8 colourways

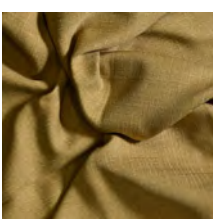

Cato FR
13 colourways

SPECIFICATIONS

Introduction to fabrics continued:

Sheers as: Sheer Lined Curtains

Sheer fabrics can be lined with one of our 3 lining designs. A lined sheer curtain provides the softness of a sheer fabric that is also combined with the insulating advantages of the applied lining. Available in:

Note: FR = Fire Retardant



Cavalier Sheers
26 colourways



Coastal Sheers FR
8 colourways

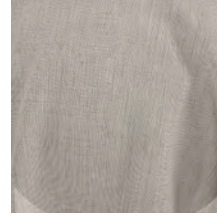

Antipodes Sheers
12 colourways



Martinique Sheers FR
11 colourways



Pilbara Sheers FR
12 colourways



Southport Sheers FR
32 colourways

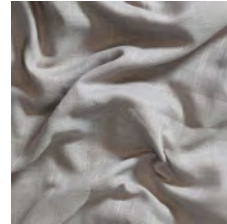

Easton Sheers FR
10 colourways

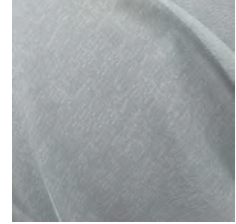

Sencha Sheers FR
9 colourways

Curtains (requires a lining)

Fabrics are lined with your choice of block-out or dim-out lining to enhance their opacity and insulating qualities.

Available in:



Borneo FR
8 colourways



Motion FR
23 colourways

Linings

Linings add weight and fullness to the appearance of your curtains. They add a protective layer which prolongs the life of curtains, and enhances thermal qualities.

Available in:

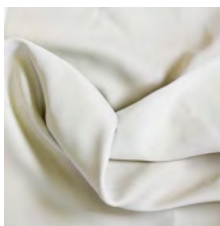

Satinline 3 Pass
Blockout Flock
Coated lining in
Ivory only

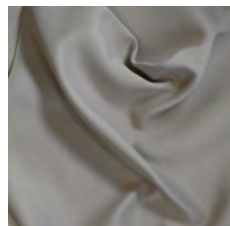

Twilight Triple
Weave Dim-out
Lining FR
15 colourways

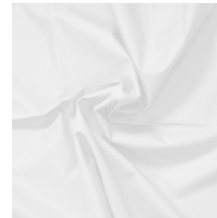

Simplicity
Silicone Block-
out 320cm
23 colourways

Custom Made Curtain Heading Styles



Single Pleat
100mm-120mm apart
Fullness 1:1.85



Double Pleat
100mm-120mm apart
with bar tack stitch
Fullness 1:2



Inverted Pleat
100mm-120mm apart
Fullness 1:1.85



Pencil Pleat
50mm-75mm heading
tape
Fullness 1:2

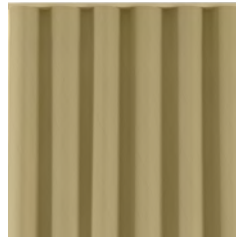

S-Fold Wave Pleat
Nylon clear heading
tape 75mm
Fullness 1:1.85



New York Pleat
100mm-120mm apart
Fullness 1:1.85

Curtain Tracks

Kingtrack Royal Standard Track
For Face Fit, single and double track options

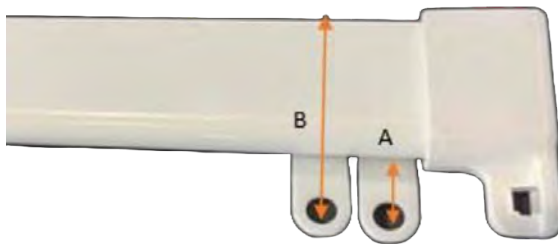

A=10mm

B=35mm



Single Bracket



Double Bracket

120mm-140mm
(70mm-90mm to back track)



Single Bracket

80mm-95mm



White



Canvas



Silver



Black

Note: Tracks can be specified with custom colour

- Use as a single track
- Can be installed on a double face fit bracket = 120-140mm projection, as a front & back track
- Brackets are extruded plastic, projecting:
 - 55-65mm single track
 - 80-95mm single track
 - 120-140mm single or double track
- Covers supplied for Bracket Footing
- Royal Track suitable for 5 heading styles (excluding S-Fold - refer to the Top fix only, tethered glide Fineline track)
- Max length 6.5m
- Bends available:
 - Standard bend
 - Reverse bend
 - Mitred corner
- Cord draw available
- No Motorisation
- Standard Appliance White, Canvas, Black & Silver colours
- Powder coated colouring available

Curtain Tracks continued...

Supreme Track Rod

Face Fit



A= 15mm



White



Canvas



Silver



Black

Note: Tracks can be specified with custom colour

FinelineSystem

Top Fit with Brackets

Standard Glide and Tethered Glide option



- Use as a single track
- Can be installed on a double face fit bracket = 120-140mm projection, as a front rod track
- Brackets are extruded plastic, projecting:
 - 55-65mm single track
 - 80-95mm single track
 - 120-140mm single or double track
- Bracket covers supplied for Bracket Footing
- Suitable for all 4 curtain product types
- Max length 6.5m
- Bends available:
 - Standard bend
 - Mitred corner
- Cord draw available
- No Motorisation
- Standard Appliance White & Canvas colour
- Powder coated colour available

- Use as a single track only
- Install top fix side by side for double track
- Suitable for all 4 curtain product types
- Max length 6.5m
- No Bends
- No Cord draw, hand drawn only
- No Motorisation
- Standard White colour
- All curtain types hang below the track
- For S-Fold Wave styled curtains, use the Fineline **tethered glides** track system

Track Bending Information

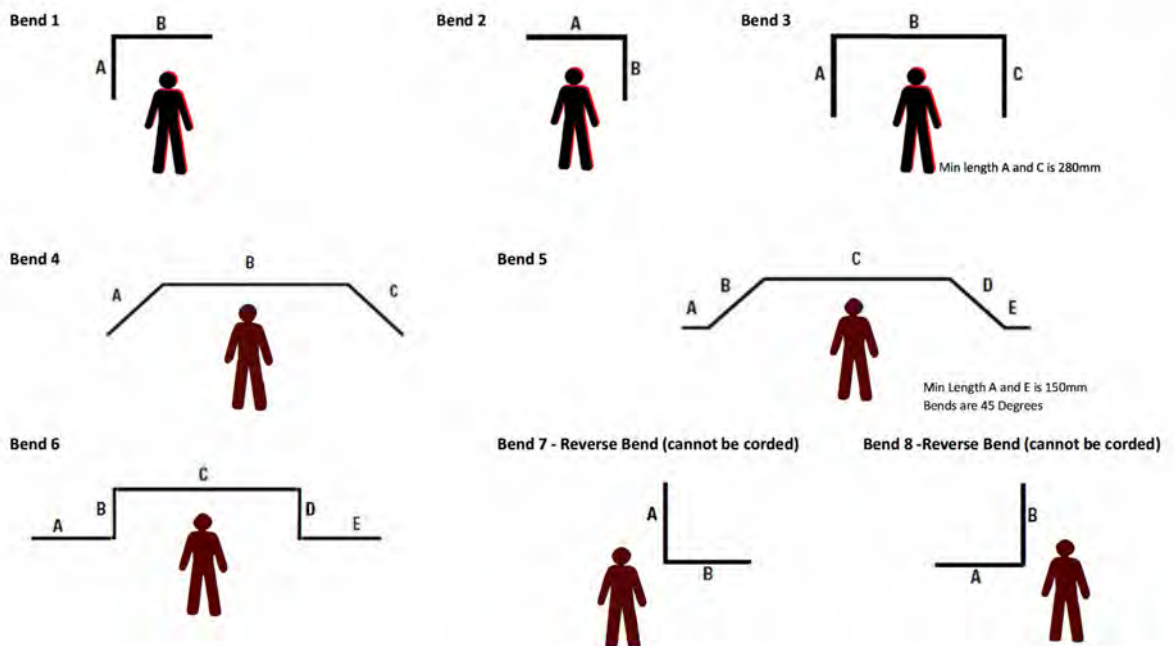

Note: Motorised Tracks are available. Please enquire directly with one of our team.



Mystique® “a curtain and blind in one”



SPECIFICATIONS

Mystique® - Overview



The Mystique® is a recent addition to the Window Treatments product range. A hybrid of a curtain and blind, Mystique® offers block out and light filtering in one. The perfect application for French or sliding doors

Operating Mystique®

Mystique is available with two control options, Manual or Motorised. Both options enable Mystique to be drawn to either side or with a centre opening.

Motorised: The motorised option is manufactured using a unique German designed traversing headrail system. This high-quality head rail system is manufactured under license exclusively by Window Treatments NZ Ltd and is available in three track colours, white, anodized and black. Rotation and traversing control is via a remote or through a building management system. Note: It is normal for the head rail system to emit a mechanical sound during traversing and altering the angle of Mystique®. Motorised Mystique can be manufactured up to a width of 5000mm and drop (height) of up to 2800mm. For new builds, Window Treatments can also supply a ceiling recess aluminium profile to fully conceal the headrail within the ceiling cavity.

Manual: The manual option is manufactured with a premium head rail tracking system from Louvolite United Kingdom. The system enables Mystique to be controlled by a continuous chain loop for rotation and a continuous pull cord for traversing. Note: It is normal for the head rail system to emit a mechanical sound during traversing and rotation of Mystique®. Manual Mystique can be manufactured up to a width of 4000mm and drop (height) of up to 2800mm.



Manual control



Motorised control

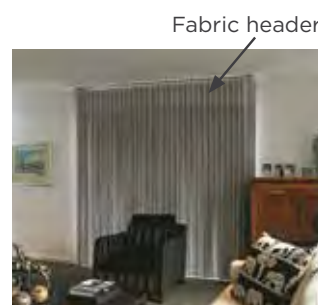
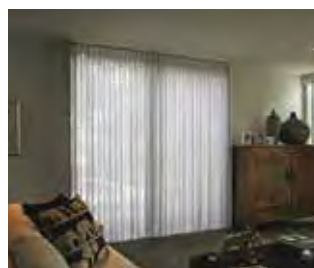
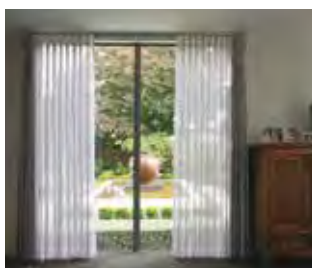

SPECIFICATIONS

Sec. : Mystique®
Date : May 2021

Mystique® - Installation Types

SPECIFICATIONS

Mystique® Fabric Colours:

Colours: Black, Honey, Sand, Dove, Stone, Tusk, Kinetic

TECHNICAL DATA	Black, Dove, Honey, Sand, Stone	Tusk, Kinetic
COMPOSITION	100% Polyester	100% Polyester
FABRIC THICKNESS	0.37mm & 0.18mm	0.35mm & 0.14mm
FABRIC WEIGHT	204 gsm	251 gsm
LIGHT FASTNESS	<4	<4

Head Rail and Componentry Options

The Mystique® head rail, Control and Idle ends and operating chain are available in three standard colours; White, Black and Anodised/Grey. Head rail custom colours are available on request with a small surcharge.

Motors are available in white, black and grey and cannot be custom coloured. Travellers for motorised are available in grey only. Travellers for manual control are white only.

Head Rail Sizes

There are three different head rail sizes which are selected based on the following factors:

- The fixing position (see below)
- Motorised or manual operation

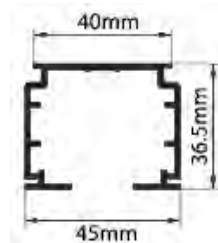

Low Profile - Motorised for recess Fix

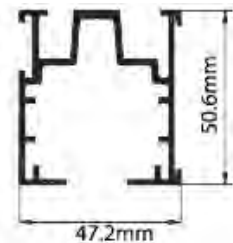

High Profile - Motor for Face Fix

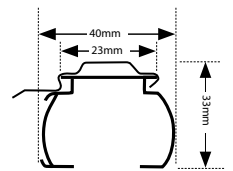

New Profile - for "Manual Control"

Fixing Position

Mystique® offers five different fixing positions to best suit your application.

1. Top Fix

One of our most common fixing position is top fix inside a reveal, recessed or fixed directly to the ceiling.



Manual control

< Manual Operation -
Low profile head rail

Motorised Operation - >

High profile head rail
(screwed through profile into fixing)



2. Top Fix with extension brackets

Installations in narrow reveals where clearance may be needed for protruding handles or mullions, we can top fix the head rail with extension brackets. Extension brackets are used allowing Mystique® to clear any objects that may affect its operation.



Manual Operation - Low Profile Head Rail



Front View
Motorised version only - High Profile Head Rail



Rear View

Mystique® - Installation Types



3. Face Fix

Face fix allows for installation outside of the window frame. Mystique® can either be fixed on or above the reveal with extension brackets used to clear any protruding objects.



Manual Operation - Low Profile Head Rail



Front View
Motorised version only - High Profile Head Rail



Rear View

4. Recess Head Rail Fix

Motorised Mystique® can be recessed into a recess channel for the low profile head rail, designed to fit seamlessly into the ceiling cavity. This option completely conceals the head rail within the recess providing a full uninterrupted drop of fabric from the ceiling to the floor.

The recess channel is only available for low profile motorised versions. The motor is positioned on top of the Mystique® head rail rather than at the back of the head rail. This means that at the motor end of the head rail, extra clearance above the head rail of 52mm(H) x 350mm(L) is required to accommodate the motor.

The recess channel requires a clearance of 110mm from centre of channel to the interior, and 60mm clearance from the centre of the channel to the glass.



Motorised version only
Low Profile Head Rail & Recess Channel

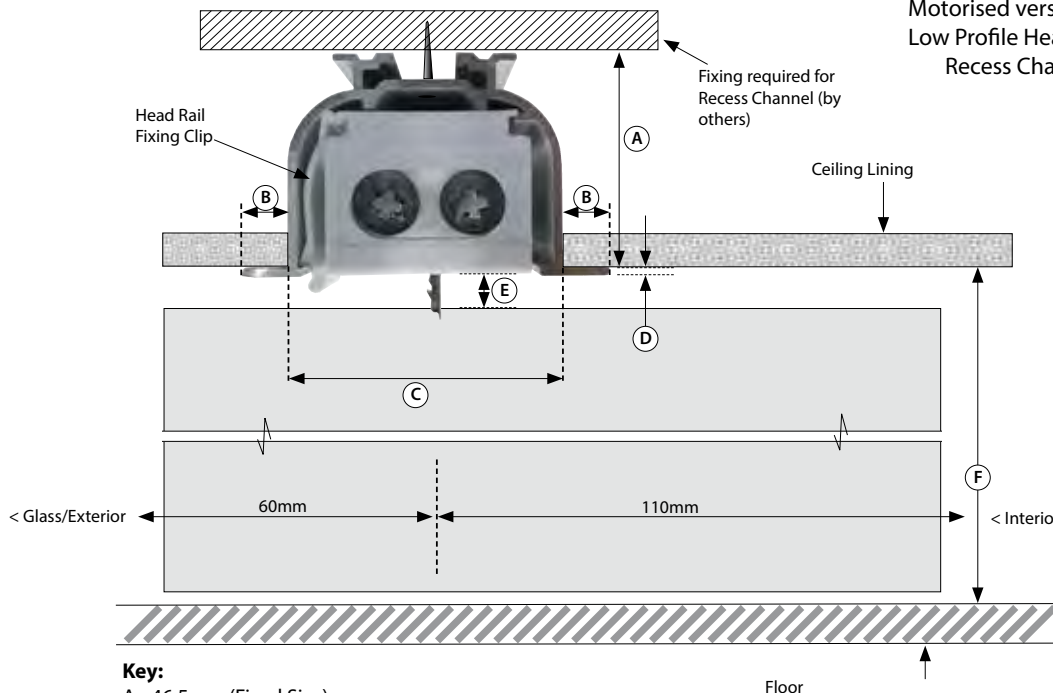

Key:

- A. 46.5mm (Fixed Size)
- B. 9.5mm (Fixed Size)
- C. 60mm (Fixed Size)
- D. 2.3mm (Fixed Size)
- E. 16mm (Fixed Size - Light Gap)
- F. Measurement required from underside of ceiling lining to the floor. Note: Window Treatments will make the necessary deduction/additions for the Head Rail/Recess Channel and floor clearance. Ceiling lining and floor should be checked for parallel.

Sec. : Mystique®
Date : May 2021

SPECIFICATIONS

5. Recess Head Rail Fix and fabric

Both the Mystique® head rail and the fabric can be completely recessed into a customised cavity providing the cavity has a minimum depth of 170mm. All head rail options are available for a recess however, if it is motorised and a low profile head rail is selected, there needs to be an extra clearance of 52mm(H) x 350mm (L) (at the motor end) above the head rail to accommodate the motor. Alternately if a high profile head rail is selected then the motor is positioned behind the head rail and therefore no extra space is required.

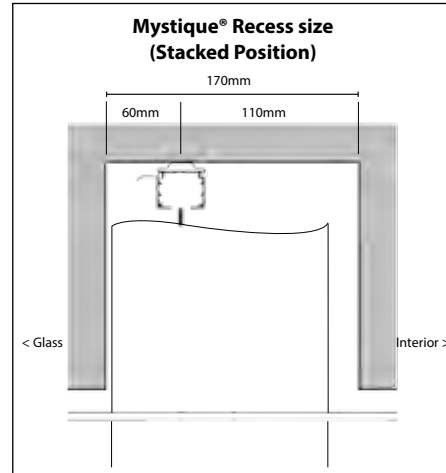

Drawing Options

There are two draw options for Mystique®: one-way draw and split draw. One-way draw allows you to choose the direction mystique® is drawn.

This option is ideal for left or right opening sliding doors as it keeps Mystique's® fabric away from thoroughfares. Split draw is a good choice for center opening doors because it keeps Mystique's® fabric to both sides making center opening doors more accessible. Note: If a split draw is selected, there will always be a gap between both sets of fabric when the Mystique is drawn over the opening. The gap can be closed by rotating the angle of Mystique using the rotation chain.



Stacking width formula

To calculate the width of Mystique's® fabric in the drawn position (stacking width) the formula below can be used:

Divide Width by 5.5 then add 50mm per side of stacking

(e.g. 2000mm one way draw / 5.5 + 50mm = 415mm Stack)

(e.g. 2000mm two way draw / 5.5 + 100mm = 464/2 = 232mm Stack per side)

Maximum & minimum size guidelines

Mystique's® maximum width is 5000mm (motorised operation) or 4000mm (manual chain control) with a maximum drop of 2800mm. If you require a larger blind, two separate mystique's® can be ordered, each with a one way draw.

Mystique's® minimum width is 400mm, and minimum drop is 400mm.

Face Fix dimensions:

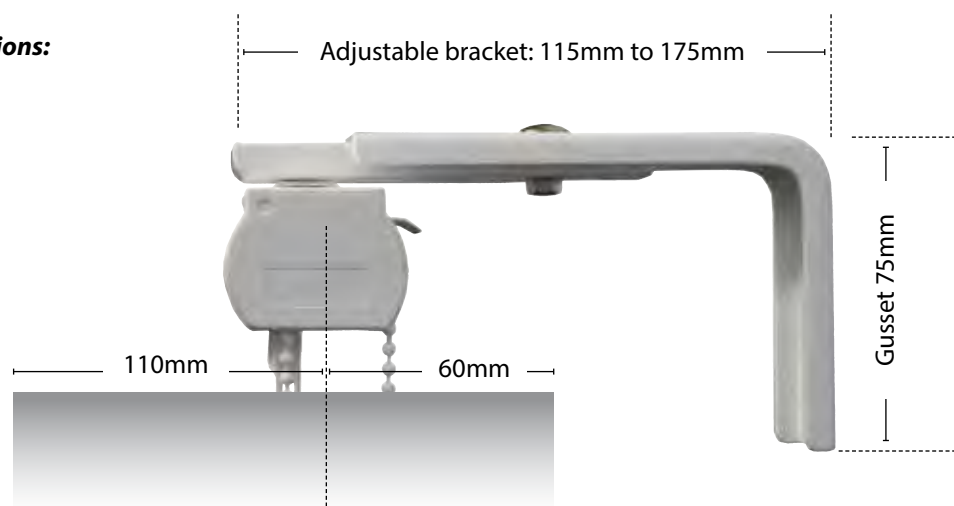



Horizontal Blinds



SPECIFICATIONS

Horizontal Blinds - Overview

Window Treatments' horizontal blind range consists of several different types: **Aluminium, Painted Timber, Stained Timber and New Image.**

Aluminium blinds are available in slat widths of 25mm & 50mm. The finish is a brushed metallic in colours to complement your decor and setting. If you are looking for a venetian blind that offers tighter closure, **privacy venetians** are manufactured using a smaller pitch 18mm ladder string which provides more overlap of the aluminium slats. All privacy venetians (irrespective of slat colour) are made with White only ladder strings.



Painted or Stained timber blinds: There are many colour options to choose from for both painted or stained timber blinds (refer chart over page). Timber blinds are ideal for your home or office décor. With all the benefits of longevity, thermal insulating and acoustic properties combined with the strengths of natural durability, our painted and stained timber blinds offer the best of both worlds. We employ the latest technology in our paint division to achieve a high quality finish on our painted timber blinds. This seamless finish means your timber blinds are water resistant and the ultra-smooth surface ensures ease of cleaning.

New Image: The most hardwearing blind in our stable has to be the **New Image** venetian blind. We have developed the New Image venetian blinds in both 50mm & 63mm slat widths for light control in high usage areas and demanding environments such as cafes, public areas and offices, and all domestic environments. A stylish, quality blind that has both the look and feel of painted wood, and with the practicality of a synthetic finish. **New Image** venetian blinds are also very cost effective and work equally well in commercial or domestic situations where a strong blind is required and budget limitations may apply. Incredibly durable, **New Image** venetian blinds are also water resistant and ideal for bathrooms and smaller windows. They are available in eight fashionable colours including three wood look colours.

Aluminium



Timber



New Image

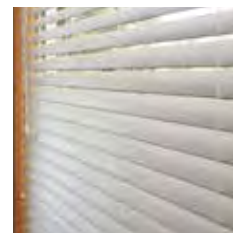

Controls for raising and tilting can be manufactured on the left or right. With the exception of aluminium blinds, fascias are standard. For face fix applications the fascia cover returns 90deg on either side. For securing the bottom rail on doors or opening windows, hold-down clips are available. For special shaped windows, horizontal blinds can be manufactured to suit raked, tapered or triangle windows.

Motorisation

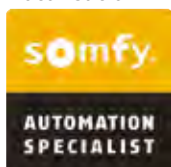

Motorisation is available on 25mm & 50mm aluminium blinds and also New Image 50mm & 63mm blinds. Blind systems can be automated via Somfy's range of Sonesse motors. These ultra quiet motors set the standard for internal blind automation. Somfy's wide range of control options include hand held radio remote control with a scroll wheel for precision tilt positioning, timers, sensors and even a full building management system. Refer to Motorisation Section. Window Treatments NZ Ltd is an Authorised Somfy Automation Specialist.



SPECIFICATIONS

Quick Glance

Type	Premium Aluminium	Privacy Aluminium	Aluminium 50mm
Slat Size	25mm	25mm	50mm
Slat Material	Hi-Tensile Aluminium	Hi-Tensile Aluminium	Hi-Tensile Aluminium
Controls	Left or Right (see notes 1, 2 & 3)	Left or Right (see notes 1, 2 & 3)	Left or Right (see notes 1, 2 & 3)
Finish	Standard Colours: Almond Frost, B10 Indigo, Bright Silver, Chinchilla, Gloss White, Krypton, Moderato (Z3), Napa, New Honey, New White, Nickel, Onyx, Silver Sand, Sparkling Alabaster, T6 Ivory, U6 Metal, Z2 Matte Black, Perforated also available	Standard Colours: Almond Frost, B10 Indigo, Bright Silver, Chinchilla, Gloss White, Krypton, Moderato (Z3), Napa, New Honey, New White, Nickel, Onyx, Silver Sand, Sparkling Alabaster, T6 Ivory, U6 Metal, Z2 Matte Black,	Gloss White Hunter Green Indigo U6 Metal Neon Blue New Honey Ruby
Maximum Width	2400mm	2400mm	2400mm
Minimum Width (see notes 1, 2 & 3)	200mm	350mm	200mm
Maximum Drop (see note 3)	2700mm	2700mm	2400mm
Minimum Drop	200mm	270mm	200mm
Maximum m² with 3 yr warranty and manageable pull up weight	6.5m ²	6.5m ²	5.5m ²
Fascia	Nil	Nil	Nil
Head Box	Aluminium	Aluminium	Steel
Bottom Rail	Aluminium	Aluminium	Steel
Hold Down Clips	Yes	Yes	Yes
Special shapes	Yes	No	Yes
Cavity Blinds	Yes	No	No
Motorisation	Yes	No	Yes
Stacking Height Formula	Drop (mm) x 0.023 + 30mm = stacking height (mm)	Drop (mm) x 0.023 + 30mm = stacking height (mm)	Drop (mm) x 0.023 + 70mm = stacking height (mm)
Special note 1)	A blind with width between 200mm and 269mm has no cord lock so cannot be raised but can be tilted.		A blind with width between 200mm and 269mm has no cord lock so cannot be raised but can be tilted.
Special note 2)	A blind with width between 270mm and 349mm can be raised and tilted however the cord lock and tilt control must be on opposite sides of the head rail.		A blind with width between 270mm and 349mm can be raised and tilted however the cord lock and tilt control must be on opposite sides of the head rail.
Special note 3)	Maximum and minimum measurements are our recommendations only. It may be possible to manufacture Venetians Blinds outside these guidelines, please contact us if in doubt.	Maximum and minimum measurements are our recommendations only. It may be possible to manufacture Venetians Blinds outside these guidelines, please contact us if in doubt.	Maximum and minimum measurements are our recommendations only. It may be possible to manufacture Venetians Blinds outside these guidelines, please contact us if in doubt.
Special note 4)			
Special note 5)			

Sec. : Horizontal
Date : Dec 2020

Quick Glance

Type	Timber Painted	Timber Stained	Timber Painted	Timber Stained	New Image
Slat Size	50.8mm	50.8mm	63.5mm	63.5mm	50mm & 63mm
Slat Material	Wood	Wood	Wood	Wood	Polystyrene
Ladder Cord or Cloth Tape	Privacy Ladder Cord or Cloth Tape (see notes 6 & 7)	Privacy Ladder Cord or Cloth Tape (see notes 6 & 7)	Privacy Ladder Cord or Cloth Tape (see notes 6 & 7)	Privacy Ladder Cord or Cloth Tape (see notes 6 & 7)	Standard Ladder cord
Controls	Left or Right (see notes 1, 2 & 3)	Left or Right (see notes 1, 2 & 3)	Left or Right (see notes 1, 2 & 3)	Left or Right (see notes 1, 2 & 3)	Left or Right (see notes 1, 2 & 3)
Finish	Painted Standard Colours: Pure White, Silk White, Pearl, Crisp Linen, String, Sea Mist, Hall Gray, Stone Gray, Brown Gray, Clay, Decorators White, Storm Gray, Taupe Gray, Chelsea Gray	Stained Standard Colours: Rustic Gray, Weathered Teak, Limed White, Taupe, Oak Mantel, Cherry, Dark Teak, Cordovan, Mahogany, New Ebony, Black Walnut, Red Oak, Old Teak, Dark Mahogany, Wenge, Matte Black, French Oak (see note 4)	Painted Standard Colours: Pure White, Silk White, Pearl, Crisp Linen, String, Sea Mist, Hall Gray, Stone Gray, Brown Gray, Clay, Decorators White, Storm Gray, Taupe Gray, Chelsea Gray	Stained Standard Colours: Rustic Gray, Weathered Teak, Limed White, Taupe, Oak Mantel, Cherry, Dark Teak, Cordovan, Mahogany, New Ebony, Black Walnut, Red Oak, Old Teak, Dark Mahogany, Wenge, Matte Black, French Oak (see note 4)	Standard colours: White Wash, Appliance White, Decorator White, Silk White, Crisp Linen Pearl, Red Oak, French Oak, Textured Black
Maximum Width (see note 3)	2700mm	2400mm	2700mm	2400mm	2400mm
Minimum Width (see notes 1, 2 & 3)	175mm	175mm	175mm	175mm	200mm
Maximum Drop (see note 3)	3048mm	3048mm	3048mm	3048mm	2550mm
Minimum Drop	254mm	254mm	254mm	254mm	200mm
Maximum m² with 3 yr warranty and manageable pull up weight	7.43m ²	7.43m ²	7.43m ²	7.43m ²	3.5m ²
Fascia	Wood	Wood	Wood	Wood	Polystyrene
Head Box	Steel	Steel	Steel	Steel	Steel
Bottom Rail	Wood	Wood	Wood	Wood	Polystyrene
Hold Down Clips	Yes	Yes	Yes	Yes	Yes
Special shapes	No	No	No	No	No
Cavity Blinds	No	No	No	No	No
Motorisation	No	No	No	No	Yes
Stacking Height Formula	Drop (mm) x 0.1 + 75mm = stacking height (mm)	Drop (mm) x 0.1 + 75mm = stacking height (mm)	Drop (mm) x 0.08 + 60mm = stacking height (mm)	Drop (mm) x 0.08 + 60mm = stacking height (mm)	Drop (mm) x 0.1 + 75mm = stacking height (mm)

SPECIFICATIONS



SPECIFICATIONS

Type	Timber Painted	Timber Stained	Timber Painted	Timber Stained	New Image
Slat Size	50.8mm	50.8mm	63.5mm	63.5mm	50mm & 63mm
Special note 1)	A blind with width of 175mm to 314mm has no cord lock so cannot be raised but can be tilted.	A blind with width of 175mm to 314mm has no cord lock so cannot be raised but can be tilted.	A blind with width of 175mm to 314mm has no cord lock so cannot be raised but can be tilted.	A blind with width of 175mm to 314mm has no cord lock so cannot be raised but can be tilted.	A blind with width between 200mm and 269mm has no cord lock so cannot be raised but can be tilted.
Special note 2)	A blind with width between 315mm and 468mm can be raised and tilted however the cord lock and tilt control must be on opposite sides of the head rail.	A blind with width between 315mm and 468mm can be raised and tilted however the cord lock and tilt control must be on opposite sides of the head rail.	A blind with width between 315mm and 468mm can be raised and tilted however the cord lock and tilt control must be on opposite sides of the head rail.	A blind with width between 315mm and 468mm can be raised and tilted however the cord lock and tilt control must be on opposite sides of the head rail.	A blind with width between 270mm and 349mm can be raised and tilted however the cord lock and tilt control must be on opposite sides of the head rail.
Special note 3)	Maximum and minimum measurements are designed to ensure trouble free operation.	Maximum and minimum measurements are designed to ensure trouble free operation.	Maximum and minimum measurements are designed to ensure trouble free operation.	Maximum and minimum measurements are designed to ensure trouble free operation.	Maximum and minimum measurements are designed to ensure trouble free operation.
Special note 4)			Stain colour ND246 Matt Black – A one-off surcharge per order of \$100 is to be applied for an order that includes 1 to 10 blinds, and 11 plus blinds per order is a \$200 surcharge	Stain colour ND246 Matt Black – A one-off surcharge per order of \$100 is to be applied for an order that includes 1 to 10 blinds, and 11 plus blinds per order is a \$200 surcharge	
Special note 5)	The slats on a 50.8mm Wood blind with privacy ladder cords, do not have slot cut-outs. This provides improved closure/privacy and less light intrusion, however the slats will not align as consistently as the Cloth tape option (refer below)	The slats on a 50.8mm Wood blind with privacy ladder cords, do not have slot cut-outs. This provides improved closure/privacy and less light intrusion, however the slats will not align as consistently as the Cloth tape option (refer below)	The slats on a 63.5mm Wood blind with privacy ladder cords , do not have slot cut-outs. This provides improved closure/privacy and less light intrusion, however the slats will not align as consistently as the Cloth tape option (refer below)	The slats on a 63.5mm Wood blind with privacy ladder cords , do not have slot cut-outs. This provides improved closure/privacy and less light intrusion, however the slats will not align as consistently as the Cloth tape option (refer below)	
Special note 6)	The slats on a 50.8mm Wood blind with cloth tape, have slot cut-outs. The decorative cloth tape conceals the cut-outs which reduces light intrusion and helps ensure the slats will always align. There is less closure/privacy with the decorative cloth tape compared to the Privacy Ladder cord option (refer above)	The slats on a 50.8mm Wood blind with cloth tape, have slot cut-outs. The decorative cloth tape conceals the cut-outs which reduces light intrusion and helps ensure the slats will always align. There is less closure/privacy with the decorative cloth tape compared to the Privacy Ladder cord option (refer above)	The slats on a 63.5mm Wood blind with cloth tape , have slot cut-outs. The decorative cloth tape conceals the cut-outs which reduces light intrusion and helps ensure the slats will always align. There is less closure/privacy with the decorative cloth tape compared to the Privacy Ladder cord option (refer above)	The slats on a 63.5mm Wood blind with cloth tape , have slot cut-outs. The decorative cloth tape conceals the cut-outs which reduces light intrusion and helps ensure the slats will always align. There is less closure/privacy with the decorative cloth tape compared to the Privacy Ladder cord option (refer above)	
Special note 7)	Cloth tape colour options: T001A White T401A Cherry T501A Wheat T303A Dark Mulberry T002A Ivory T402A Light Cocoa 5124A Dusty Gray T201A Black T003A Bone T403A Ecru 5416A Chocolate 5507A Natural T169A Gray Beige 5414A Brown 5434A Dark Sienna 5462A Black Brown	Cloth tape colour options: T001A White T401A Cherry T501A Wheat T303A Dark Mulberry T002A Ivory T402A Light Cocoa 5124A Dusty Gray T201A Black T003A Bone T403A Ecru 5416A Chocolate 5507A Natural T169A Gray Beige 5414A Brown 5434A Dark Sienna 5462A Black Brown	Cloth tape colour options: T001A White T401A Cherry T501A Wheat T303A Dark Mulberry T002A Ivory T402A Light Cocoa 5124A Dusty Gray T201A Black T003A Bone T403A Ecru 5416A Chocolate 5507A Natural T169A Gray Beige 5414A Brown 5434A Dark Sienna 5462A Black Brown	Cloth tape colour options: T001A White T401A Cherry T501A Wheat T303A Dark Mulberry T002A Ivory T402A Light Cocoa 5124A Dusty Gray T201A Black T003A Bone T403A Ecru 5416A Chocolate 5507A Natural T169A Gray Beige 5414A Brown 5434A Dark Sienna 5462A Black Brown	

Sec. : Horizontal
Date: Feb 2023

Aluminium - Technical Data



Aluminium Technical Data

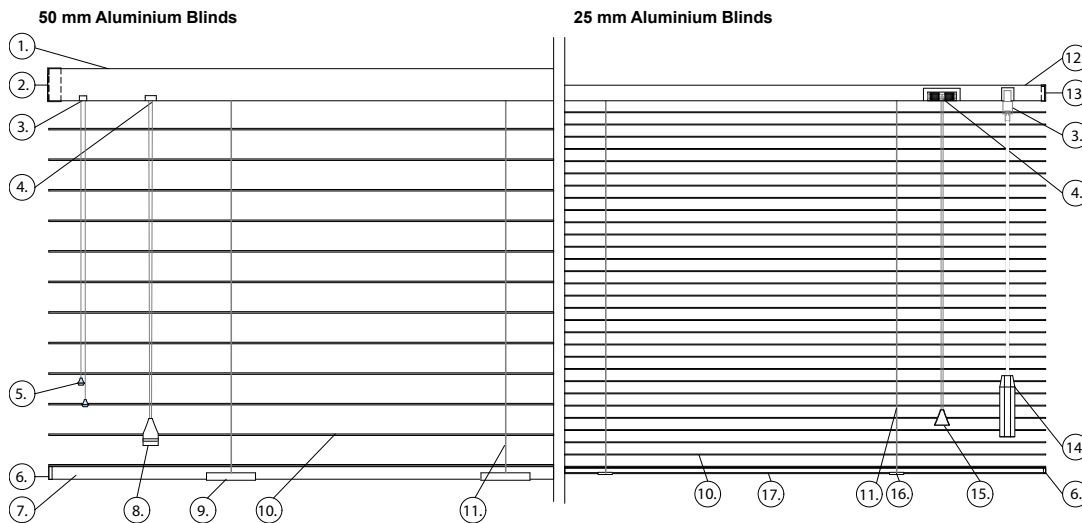

Key

- | | |
|-----------------------------|----------------------------------|
| 1. Head Rail – Metal | 10. 50 & 25mm Slat – Aluminium |
| 2. Mounting Bracket – Metal | 11. 50 & 25mm Ladder – Polyester |
| 3. Tilt Cord – Polyester | 12. Head Rail – Aluminium |
| 4. Cord Lock - Metal | 13. Mounting Bracket – Plastic |
| 5. Tilt Cord Toggle – Wood | 14. Tilt Wand |
| 6. End Cap - Plastic | 15. Cord Lock Toggle – Plastic |
| 7. Fascia Clip – Plastic | 16. Bottom Clip – Plastic |
| 8. Cord Lock Toggle – Wood | 17. Bottom Rail - Aluminium |
| 9. Bottom Clip - Metal | |

50 mm Aluminium Blinds

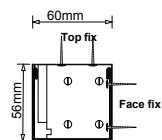

25 mm Aluminium Blinds

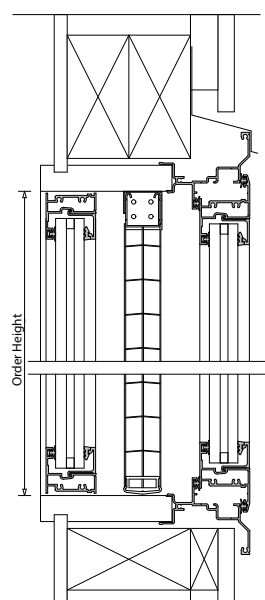
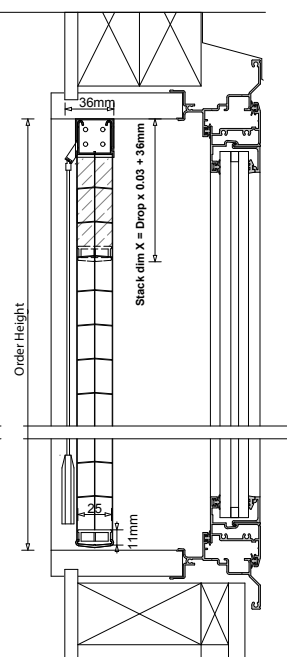
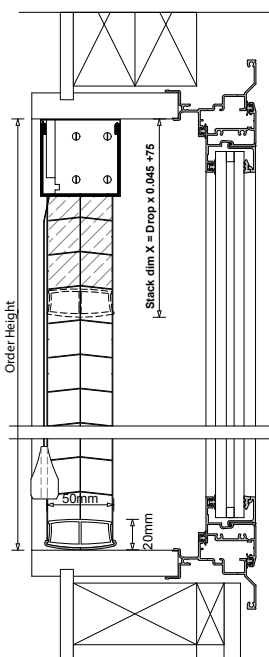
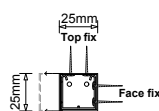

Cavity Blinds (25mm Aluminium)

Permanently sealed motorised venetian blinds within the cavity are the perfect application for hospitals, medical centres, government buildings and schools. Sealed in this totally dust free environment makes them low maintenance and extremely hygienic.

SPECIFICATIONS

Sec. : Horizontal
Date: May 2021

Timber, New Image

- Technical Data

SPECIFICATIONS

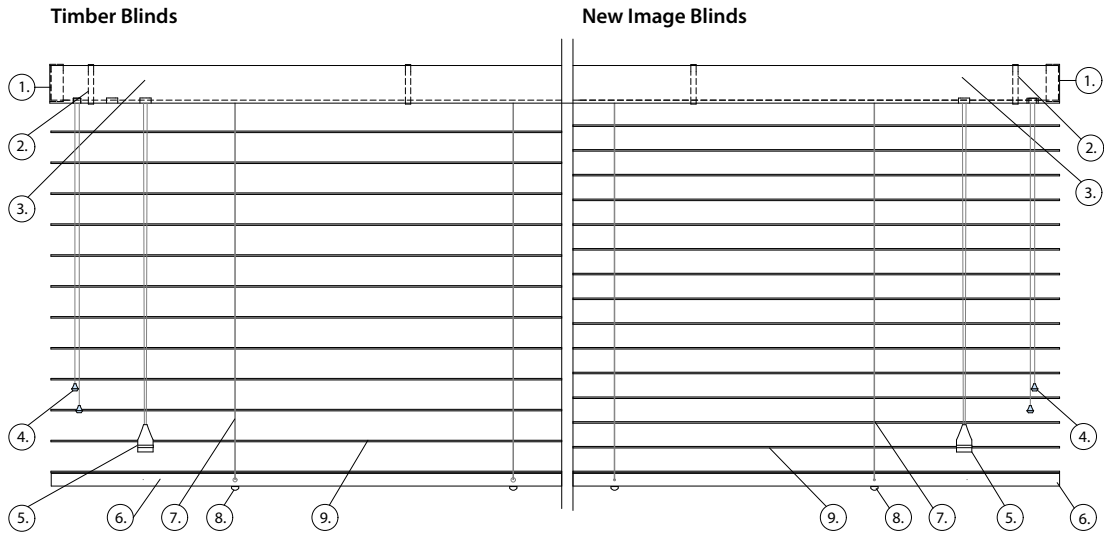

Key

- 1. Mounting Bracket – Metal
- 2. Fascia Clip – Plastic
- 3. Head Rail - Metal
- 4. Tilt Cord Pull & Toggle – Polyester & Wood
- 5. Cord Lock Pull & Toggle – Polyester & Wood
- 6. Bottom Rail – Wood Blinds - Wood
- 6. Bottom Rail - New Image - Polyester
- 7. Ladder – Polyester
- 8. Pin Button - Wood
- 9. Wood Slat
- 9. New Image (Polystyrene Slat)



Typical Blind Detail

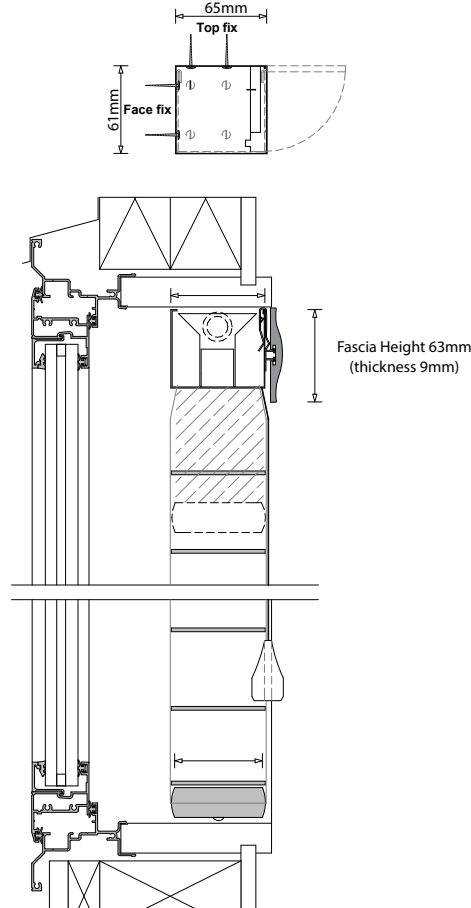

Horizontal Blinds - Motorisation

Horizontal Blinds - Motorisation

Motorisation control is available on Aluminium 25mm & 50mm venetians and New Image 50mm & 63mm Blinds. Automation is via Somfy's range of Sonesse motors. These ultra-quiet motors set the standard for internal blind automation. Somfy's wide range of control options include hand held radio remote control with a scroll wheel for precision tilt positioning, timers, and even a full building management system. Window Treatments NZ Ltd is an authorized Somfy automation specialist.

240 Volt AC Motor: Sonesse 40

Performances	Sonesse 3/30	Sonesse 6/20	Blind Type >	Aluminium 50mm	New Image
Torque	3nm	6nm	Min Width	665mm	665mm
Nominal Voltage	230v	230v	Max Width	2400mm	1800mm
Rated Current	0.44	0.55	Min Drop	300mm	300mm
Rated Power	95W	120W	Max Drop	2400mm	2100mm
Speed	30RPM	20RPM			
Thermal Protection	4 Min	4 Min			
Radio Frequency	433.42	433.42			
Sound Level (DB)	42	45			
Cable Length	2500mm	2500mm			
IP Rating	IP 44	IP 44			
Insulation Class	II	II			

24 Volt DC Concept 25 System - Motor: LV25

Performances	LV25 - B44	Blind Type >	Aluminium 25mm (Short Cone)	Aluminium 25mm (Long Cone)
Torque	0.4nm	Min Width	600mm	670mm
Speed	40rpm	Max Width	2400mm	2400mm
Rated Voltage	24V	Min Drop	300mm	300mm
Rated Current	0.3A	Max Drop	1700mm	3000mm
Running time before thermal cut off	7 Min			
Motor Weight	0.145kg			
IP Rating	IP 40			

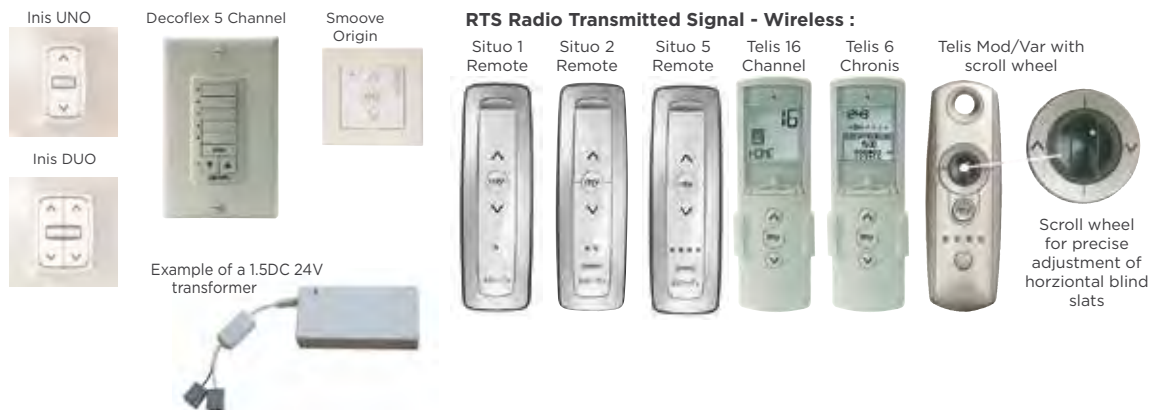

Wall switches or Remote controls can be used to manage a blind or groups of blinds with tilting slats equipped with RTS technology as well as activate or take control of a sun sensor. With the Telis Mod/Var with Scroll Wheel, slats are precisely positioned using a central thumbwheel. Up, down, stop and preferred position settings are achieved using the « my » key. Available in Pure, Silver and in single channel model

Sec. : Horizontal
Date : Feb 2023

SPECIFICATIONS



SPECIFICATIONS

Sec. : Horizontal
Date: May 2021



Honeycomb Pleated Blinds



SPECIFICATIONS

Sec. : Honeycomb
Date : Nov 2022



Honeycomb Pleated Blinds

SPECIFICATIONS



Product - Overview



Product Overview



Honeycomb Pleated Blinds offer excellent insulation with an attractive combination of high fashion, good value, easy installation and convenient operation. Simply styled and designed, Honeycomb blinds are an economical option in soft window coverings. Choose from a selection of decorative block-out or light-filtering fabrics. The head and bottom rails are manufactured from extruded aluminium alloy and fixed to the window with steel brackets. In addition to standard free hanging rectangular blinds, we offer a range of shapes that deliver solutions for many typical windows. For skylight blinds please refer to our Blocco Section (Blocco Honeycomb)

Motorised Operation: refer to Motorisation page later in this section

Manual Operation options for Honeycomb Pleated Blinds:

1. Cord Lock: Operation with a cord lock is very similar to Venetian blinds. Raising and lowering of the blind is achieved by means of colour co-ordinated pull cords. There are three configuration options available with the Cord Lock operation:

a. Cord Lock: The honeycomb blind can be locked in any position between fully raised and fully lowered and the cords can be situated at either the left or right side of the blind.

b. Top Down, Bottom Up: This configuration requires two cord locks on the one blind (one at each end) and an additional mid-rail. This allows the blind to be stacked in any position, between the top of the window frame and the bottom of the window frame. As an example, the blind could be positioned so that the top of the fabric which is attached to the additional mid-rail, is mid-way up the window with the remaining lower section, covering the lower half of the window.

c. Day Night (using two differing Honeycomb Fabrics): This configuration also requires two cord locks on the one blind (one at each end) and an additional mid-rail. This configuration allows for two fabrics on the one blind rather than only one. The combination of fabrics selected are most often a light filtering fabric for day time use, and a block out fabric for night time use. This means that there are effectively two blinds covering the window providing both day and night time light control.

2. Cordless: A new generation control option to raise and lower the blind. Operation of a "Cordless" honeycomb pleated blind is done by raising and lowering the blind using a small handle which is attached to the bottom rail. The blind can be stopped at any position (auto brake) and as there are no cords, this option provides the optimum in child safety. There are a further two additional configuration options available with the Cordless operation:

a. Top Down, Bottom Up: This configuration is manufactured with an additional mid-rail. This allows the blind to be stacked in any position, between the top of the window frame and the bottom of the window frame. As an example, the blind could be positioned so that the top of the fabric which is attached to the additional mid-rail, is mid-way up the window with the remaining lower section, covering the lower half of the window.

b. Day Night: This configuration is manufactured with an additional mid-rail. This configuration allows for two fabrics on the one blind rather than only one. The combination of fabrics selected are most often a light filtering fabric for day time use, and a block out fabric for night time use. This means that there are effectively two blinds covering the window providing both day and night time light control.



3. Clutch: With a Clutch Control, the raising and lowering of the blind is by rotating the looped cord on the side of the blind. The cord rotates a high ratio gear inside the headrail which makes the raising and lowering of the blind very easy for large blinds. Installation:

Installation: Face fit or Inside fit for all system types.

Fabrics

The Sonata range of 45 Honeycomb pleated blind colours are available in both 25mm & 38mm block-out and light-filtering options. A special feature of a honeycomb blind is that the cords on the blind are not visible as they are fed through through the centre of the Honeycomb cells. Furthermore, both block-out and light-filtering honeycomb fabrics have superior heat retention due to the two layered cell construction. The Sonata range of light filtering fabrics create a soft focus in a stylish contemporary colour range. These fabrics gently filter sunlight, prevent UV damage and provide a flattering ambient light. Our block-out honeycomb fabrics which are 100% polyester non-woven are perfect for controlling light and offer complete privacy. If you prefer some natural light and still retain your heat our light-filtering honeycomb fabrics would provide a perfect solution.

SPECIFICATIONS

Sec. : Honeycomb
Date : May 2021

Honeycomb Pleated Blind

- 25mm & 38mm Honeycomb single cell, Cord Lock Control

SPECIFICATIONS

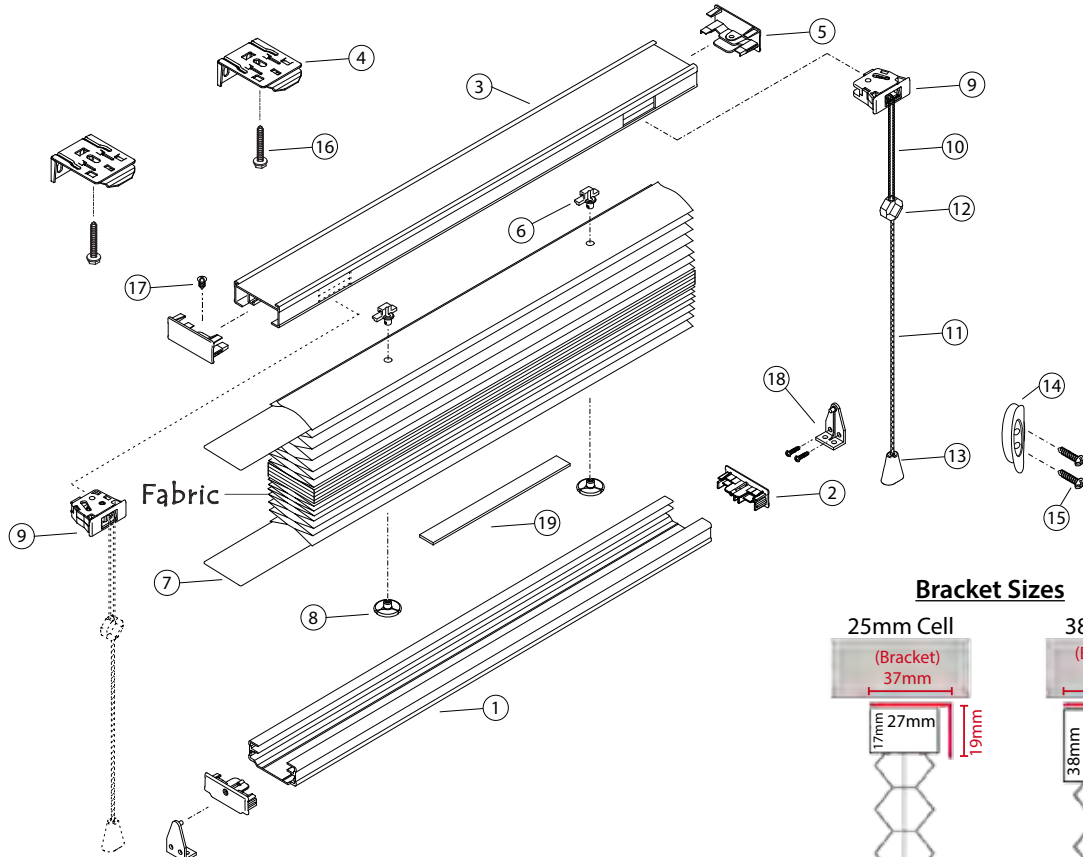

Key Numbers

- | | |
|-----------------------------------|---|
| 1. Aluminium Bottom Rail | : Colour co-ordinated
D 27mm x H 12mm - 25mm Cell
D 41mm x H 12mm - 38mm Cell |
| 2. Bottom Rail End Cap | : Colour co-ordinated |
| 3. Aluminium Head Rail | : D 27mm x H 17mm - 25mm Cell - Colour co-ordinated
D 46mm x H 38mm - 38mm Cell - White, Black colour co-ordinated, Grey Sheen colour co-ordinated, (with Fabric Insert on face) |
| 4. Mounting Bracket | : Zinc Plated |
| 5. Head Rail End Cap | : Colour co-ordinated |
| 6. Cord Guide | |
| 7. Rail Insert | |
| 8. Fix Button | : Plastic |
| 9. Cord Lock (Left/Right) | : Colour co-ordinated |
| 10. Cord (O.D. = 0.9mm) | : Colour co-ordinated |
| 11. Pulling Cord (O.D. = 1.8mm) | : Colour co-ordinated |
| 12. Stop Ball | : Colour co-ordinated |
| 13. Tassel | : Colour co-ordinated |
| 14. Cord Cleat | : Clear |
| 15. Screw for Cord Cleat | : Zinc Plated |
| 16. Screw for Mounting Bracket | : Zinc Plated |
| 17. Screw for Rail Insert | : Zinc Plated |
| 18. Hold down bracket | : (screws - zinc plated) |
| 19. Weights with double face tape | |

Bracket Sizes

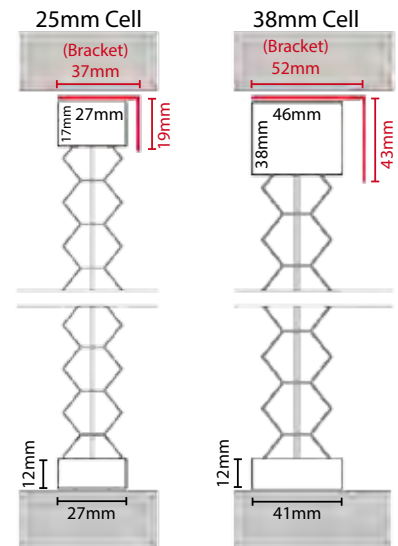

Recess Measurements

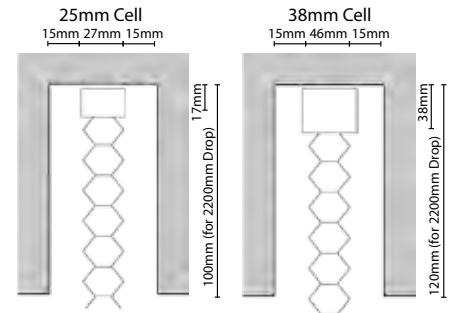

Honeycomb Pleated - Maximum Size Specifications						
Control Type		Honeycomb Type (single cell)	Min / Max Blind Size			
			Max m ²	Min Width	Max Width	Max Drop
Cord Lock (cord lock on one side)	Standard	25	6.75 m ²	200mm	2700mm	2500mm
Cord Lock (cord lock on one side)	Standard	38	6.75 m ²	200mm	2700mm	3600mm
Cord Lock (2 cord locks, 1 at each end)	Top down, bottom up	25	6.75 m ²	450mm	2700mm	2500mm
Cord Lock (2 cord locks, 1 at each end)	Top down, bottom up	38	6.75 m ²	450mm	2700mm	3600mm
Cord Lock (2 cord locks, 1 at each end)	Day & Night	25	4.56 m ²	450mm	2700mm	2500mm
Cord Lock (2 cord locks, 1 at each end)	Day & Night	25	4.56 m ²	450mm	2700mm	3600mm

Sec. : Honeycomb
Date : Nov 2022

Honeycomb Pleated Blind

- 25mm & 38mm Honeycomb single cell, Cordless

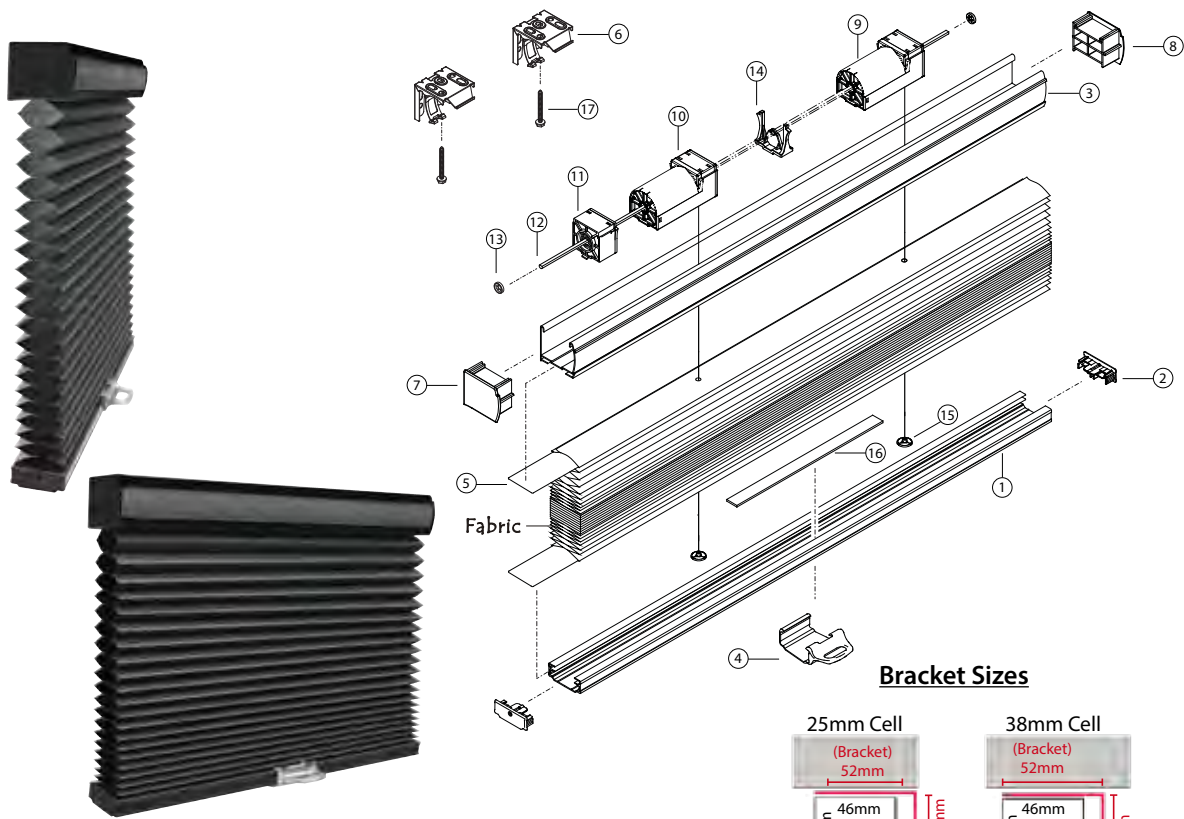

Key Numbers

- | | |
|------------------------------------|---|
| 1. Aluminium Bottom Rail | : Colour co-ordinated
D 27mm x H 12mm - 25mm Cell
D 41mm x H 12mm - 38mm Cell |
| 2. Bottom Rail End Cap | : Colour co-ordinated |
| 3. Aluminium Head Rail | : D 46mm x H 38mm - 25mm Cell- White, Black colour co-ordinated, Grey Sheen colour co-ordinated, (with Fabric Insert on face)
D 46mm x H 38mm - 38mm Cell - White, Black colour co-ordinated, Grey Sheen colour co-ordinated, (with Fabric Insert on face) |
| 4. Bottom Rail Handle | : Clear |
| 5. Rail Insert | |
| 6. Mounting Bracket | : Zinc Plated Only |
| 7. Head Rail End Cap | : Off-white |
| 8. Head Rail End Cap | : Off-white |
| 9. Cordless Module with spring | : For all Shades Width |
| 10. Cordless Module without spring | : For shade width is less than 610mm Width |
| 11. Tension Spring Module | |
| 12. Tilter Rod | : Zinc Plated |
| 13. Tilter Rod End Washer T | : Stainless |
| 14. Tilter Rod Support | : Plastic |
| 15. Fix Button | : Plastic |
| 16. Weights with Double Face Tape | |
| 17. Screw for Mounting Bracket | : Zinc Plated |

Bracket Sizes

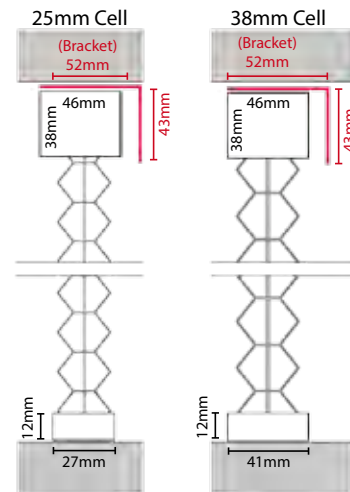

Recess Measurements

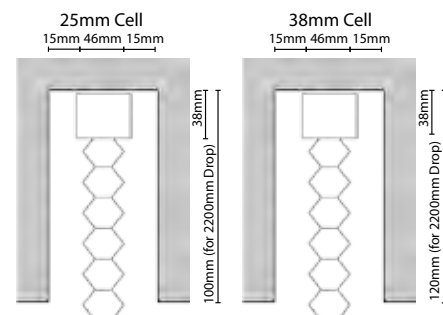

Honeycomb Pleated - Maximum Size Specifications

Control Type		Honeycomb Type (single cell)	Min / Max Blind Size			
			Max m ²	Min Width	Max Width	Max Drop
Cordless	Standard	25 mm	3.6 m ²	250mm	2000mm	1800mm
Cordless	Standard	38 mm	3.6 m ²	250mm	2000mm	1800mm
Cordless	Top down, bottom up	25 mm	3.6 m ²	550mm	2000mm	1800mm
Cordless	Top down, bottom up	38 mm	3.6 m ²	550mm	2000mm	1800mm
Cordless	Day & Night	25 mm	3.6 m ²	550mm	2000mm	1800mm
Cordless	Day & Night	38 mm	3.6 m ²	550mm	2000mm	1800mm

Sec. : Honeycomb
Date : Nov 2022

SPECIFICATIONS

Honeycomb Pleated Blind

- 25mm & 38mm Honeycomb single cell, Clutch & Motorised

SPECIFICATIONS

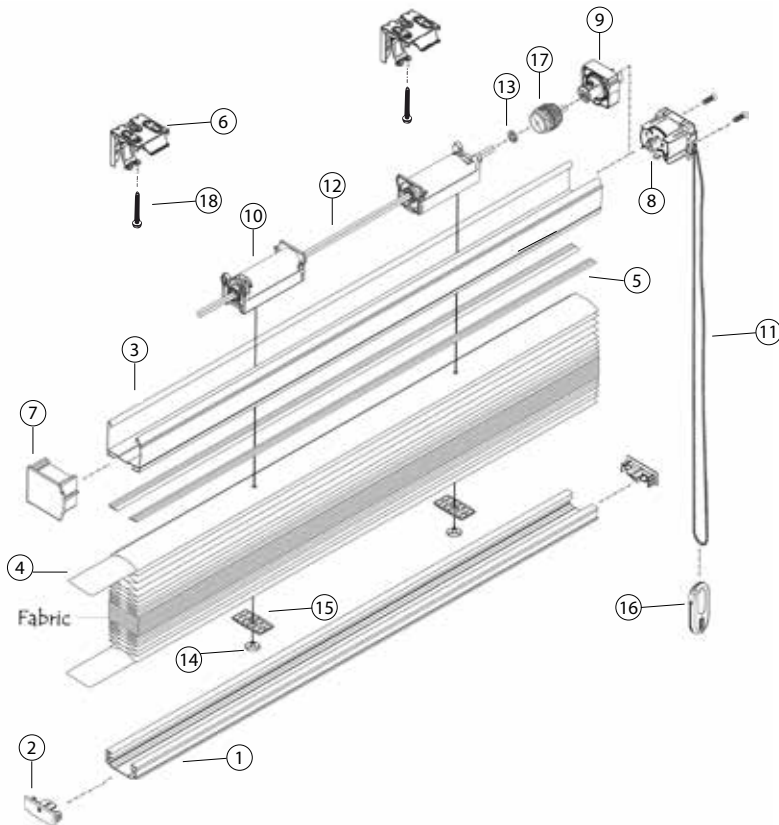

Clutch



Motorised

Key Numbers

- | | |
|---|---|
| <ul style="list-style-type: none"> 1. Aluminium Bottom Rail 2. Bottom Rail End Cap 3. Aluminium Head Rail 4. Rail Insert 5. Aluminium F Rail 6. Mounting Bracket 7. Head Rail End Cap 8. Clutch 9. Gear Box PL 10. Cordless Module Housing 11. Control Cord PL 12. Tilter Rod 13. Tilter Rod End Washer 14. Cord 15. Fix Button 16. Tension Device 17. Separator 18. Screw for Mounting Bracket | <ul style="list-style-type: none"> : Colour co-ordinated
D 27mm x H 12mm - 25mm Cell
D 41mm x H 12 mm - 38mm Cell : Colour co-ordinated
: D 46mm x H 38mm - 25mm Cell - White, Black colour co-ordinated, Grey Sheen colour co-ordinated, (with Fabric Insert on face)
D 46mm x H 38mm - 38mm Cell - White, Black colour co-ordinated, Grey Sheen colour co-ordinated, (with Fabric Insert on face) : Zinc Plated : Off-white : Off-white : For W X D \geq 3.24m² : Without Spring : Loop : Zinc Plated : Stainless : Colour coordinated : Plastic : Clear : Plastic : Zinc plated |
|---|---|

Bracket Sizes

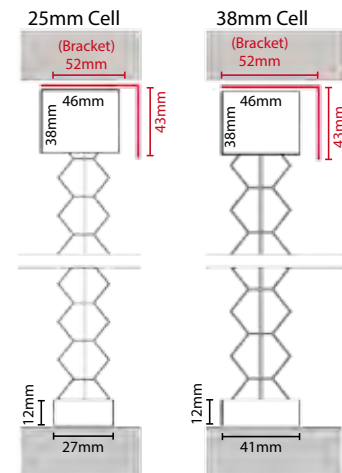

Recess Measurements

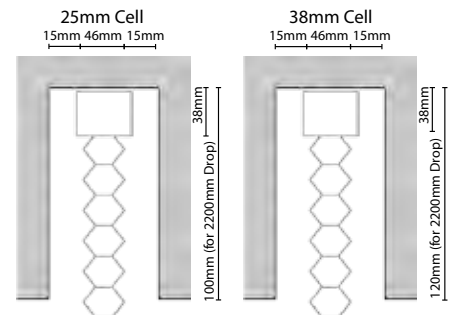

Honeycomb Pleated - Maximum Size Specifications

Control Type	Honeycomb Type (single cell)	Min / Max Blind Size			
		Max m ²	Min Width	Max Width	Max Drop
Clutch (cord on one side)	25mm	6.75 m ²	300mm	2700mm	2500mm
Clutch (cord on one side)	38mm	6.75 m ²	300mm	2700mm	3000mm
Motorised 12v with 230v transformer	25mm	6.75 m ²	840mm	2700mm	2500mm
Motorised 12v with Rechargeable Battery	38 mm	6.75 m ²	840mm	2700mm	2500mm

Sec. : Honeycomb
Date : Nov 2022

Honeycomb Pleated - Motorisation

Motorised Operation:

For windows that are out of reach such as conservatories or some commercial installations, Window Treatments can motorise your Honeycomb pleated blinds with a hard-wired Dooya 12v motor, or by an external rechargeable lithium battery. The raising and lowering of the blind is achieved with a rotating spool within the head rail which is driven by motor.

A small solar panel can also be connected to the battery pack to boost the operational life of the battery.

Control options: The blinds can be operated by remote and/or integrated into a BMS system via a Dooya HUB.

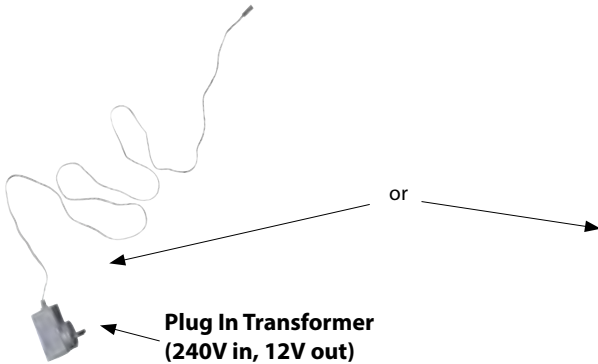

- DC1276**
12V Rechargeable Battery Wand
- For all DOOYA-DC motor (<12V, 20W)
 - Power: 11.1V 2.6Ah
 - Working life: 600 charging cycles
 - Dimension: 225mm x 27.5mm x 27.5mm

Dooya Hub



Motor
12V, 10W, .8Nm



- DC1289A**
Dooya Solar Panel
- Output voltage: 12.6V
 - Output power: 3W
 - Working Temperature: -20°C ~ + 80°C
 - Service life: 5 years
 - Dimension: 419mm x 54mm x 16mm

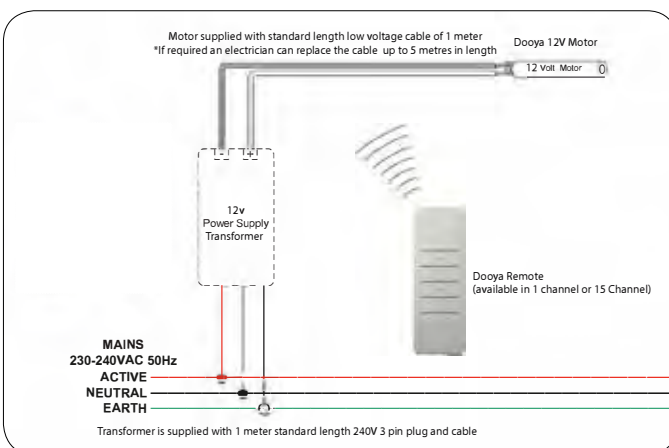

Head rail configuration

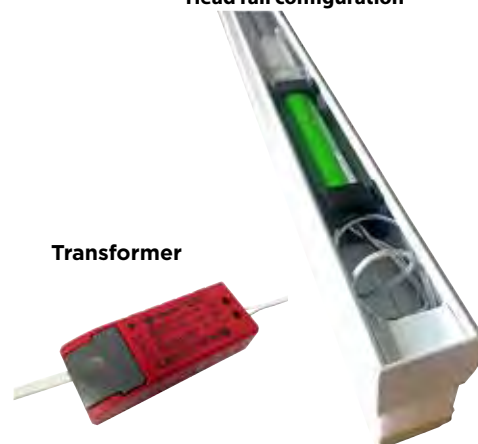

Honeycomb Pleated - Maximum Size Specifications

Control Type	Honeycomb Type (single cell)	Min / Max Blind Size			
		Max m ²	Min Width	Max Width	Max Drop
Clutch (cord on one side)	25mm	6.75 m ²	300mm	2700mm	2500mm
Clutch (cord on one side)	38mm	6.75 m ²	300mm	2700mm	3000mm
Motorised 12v with 230v transformer	25mm	6.75 m ²	840mm	2700mm	2500mm
Motorised 12v with Rechargeable Battery	38 mm	6.75 m ²	840mm	2700mm	2500mm

SPECIFICATIONS

Sec. :Honeycomb Pleated
Date : May 2021



Honeycomb Pleated - Fabric Specification

Sonata Block-out and Light Filtering Overview

The Sonata block-out Honeycomb range of fabric is available in 25mm and 38mm width pleat and 45 colours. It consists of 2 layers of fabric with a foil lined white backing . The deliberately chosen white on the reverse (the window side), ensures a uniform appearance from the outside and provides a high degree of light reflectivity. Both the inside and the outside have a subtle textile character. The foil core gives the fabric extra stability, a plus point with the extreme heat that often occurs with skylights.

If you prefer some natural light and still retain your heat our Sonata light-filtering honeycomb fabric would provide a perfect solution.

Note: The entire Sonata range is suitable for both perpendicular and skylight windows.

Sonata Block-out and Light filtering

TECHNICAL DATA	Block-out	Light-filtering
COMPOSITION	100% Polyester	100% Polyester
FABRIC THICKNESS	0.16mm	0.25mm
FABRIC WEIGHT	190 gsm	204 gsm
PLEAT HEIGHT	25mm & 38mm	25mm & 38mm
LIGHT FASTNESS	4	4
METALLIZED	Yes	No
BLOCKOUT	Yes	No

Sonata Block-out & Light-filtering (45 colours available)



SPECIFICATIONS



Shutters



SPECIFICATIONS



Shutters - Index

SPECIFICATIONS

Shutters Introduction 1-2

- Quick Glance

Basswood & Cedar Shutters..... 3

- Tilt Rod, Louvre Size & Style 4
- Stile options..... 5
- Light stop, Square Frames 6
- L Frames, T-Post 7
- Z Frame, U Channel, Corner Post 8
- Panel Types-Hinged 9-10
- Fixed Shutters 11
- Basswood Plantation Specifications... 12
- Basswood Plantation Construction..... 13
- Basswood Plantation Clearview 14
- Cedar Plantation Specifications 15
- Cedar Plantation Construction 16
- Special Shape Shutters 17
- Hardware Tracking Systems, Hinges.. 18
- Hardware Sliding Single Run 19
- Hardware Multi-fold 20

Aluminium Shutters 21

- Tilt Rod, Louvre Size & Style 22
- Light stop, L Frames, T Frames 23
- U Channel, Corner Post, Bay window . 24
- Panel Types-Hinging options 25
- Fixed Shutters 26
- Hardware Tracking Systems, Hinges.. 27
- Hardware Sliding Single Run 28
- Hardware Multi-fold 29

PVC Shutters..... 31

- Tilt Rod, Louvre Size & Style 32
- Light stop, L Frames, T Frames 33
- Z Frame, U Channel, Corner Post, Bay window 34
- Panel Types-Hinged, 35-36
- Fixed Shutters 37
- Hardware Tracking Systems, Hinges.. 38
- Hardware Sliding Single Run 39
- Hardware Multi-fold 40

Motorised Shutters..... 41

Shutters - Introduction



Opening Window:

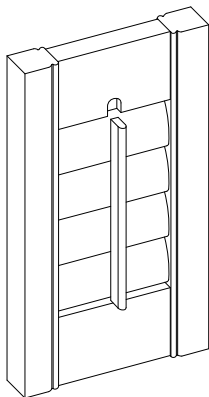

Window Treatments' traditional European styled shutters includes both interior shutters (used on the inside of a house or building) and exterior shutters (used on the outside of a structure). Depending on your application, shutters can be constructed from either Basswood, Cedar, Aluminium or PVC.

Shutters may be used for a variety of reasons: visibility and airflow, including controlling the amount of sunlight that enters a room, to provide privacy, security and to enhance the aesthetics of a building or terrace access adding to the practicality and mood of any interior or exterior.

Shutters can be either fixed permanently in place, hinged, bi-fold or sliding and come with various types of hardware and tracking systems. Depending on your requirements, shutters can be fitted inside or outside of the window opening and can be supplied with various types of frames (Z, L, T, rectangle or square). Shutters can be configured in a single tier unit that has one shutter top to bottom of a window opening as well as multiple tiers. Multiple tier units feature separate shutters on each tier which allows the top shutters to be opened independently from the bottom shutters. Café type shutters refers to shutters

that only cover the lower portion of a window. Full height shutters are made with a horizontal divider (mid-rail) which separates the upper and lower portions of the shutter. With operable louvred shutters this gives greater control as the louvres above the mid-rail can be operated independently from the louvres below the mid-rail.

Window Treatments' shutters consist of a frame of vertical stiles and horizontal rails (top, middle and bottom). Set within this frame, louvres can be adjustable or fixed within the shutter frame. Full height shutters are made with a mid-rail which separates the upper and lower portions of the shutter. A tilt bar is used for adjusting louvre position and to keep the louvres in a uniform position. Alternatively a Clear View metal tilt rod is placed on the reverse side of the shutter allowing for cleaner lines in the front. The Clear View system is commonly used for sliding shutter applications as this decreases light gap measurements and allows each shutter leaf to sit closer to one another.

Quick Glance

Type		Basswood	Cedar	Aluminium	PVC
Louvres	Louvre Size	47.6mm (aerofoil only), 64mm, 89mm, 114mm (aerofoil & flat blade)	68mm, 90mm	89mm	64mm, 89mm, 114mm
Tilt Bar	Tilt Bar Position Clear View	Centre, Left or Right Yes	Centre, Left or Right Yes	N/A Yes	Centre, Left or Right Yes
Style	Hinged Bi-fold Straight Sliding Fixed Louvres (ventilated) Fixed Louvres (non-ventilated) Special Shape Shutters	Yes Yes Yes Yes Yes Yes	Yes Yes Yes Yes Yes Yes	Yes Yes Yes Yes Yes No	Yes Yes Yes Yes Yes No
Stile Options	Square Rabbet D-mould	Yes Yes Yes	Yes Yes Yes	Yes No Yes	Yes Yes Yes
Motorised Option		Yes	Yes	Yes	Yes
Hardware	Tracking Systems Hardware	Yes Yes	Yes Yes	Yes Yes	Yes Yes
Frame Options	Stiles Mid-rail Light Stop Hang Strips L Frames Z Frames T Post U Channel Corner Post Bay Window Post	Yes Yes Yes Yes Yes Yes Yes Yes Yes Yes	Yes Yes Yes Yes Painted Only Yes Painted Only Painted Only Yes	Yes Yes *Yes - constructed from Basswood No Yes No Yes Yes *Yes - constructed from Basswood *Yes - constructed from Basswood	Yes Yes *Yes - constructed from Basswood *Yes - constructed from Basswood Yes Yes *Yes - constructed from Basswood *Yes - constructed from Basswood *Yes - constructed from Basswood
Finish	Stained Oiled Lacquered Painted Powder coated	Yes No No Yes, Stnd colours or custom No	No Yes Yes Yes, Stnd colours or custom No	No No No No Yes, Stnd colours only	No No No Yes, Stnd colours or custom No

SPECIFICATIONS

Material Type

Window Treatments' Shutter range is available in Aluminium, PVC and two types of wood, Basswood and Cedar both of which come from sustainable forests and are renowned as the most durable hardwood and softwood timbers for manufacturing shutters (this is due to their resistance to warping, fine grains, durability and acceptance of a variety of finishes).

Basswood Overview	Cedar Overview
Basswood is a hardwood, durable and lightweight. The characteristics are a fine straight grain material with an even texture, consistent colour and low resin content. Basswood has good finishing properties, accepts oil-based paint and exterior stain for longer finishes.	Cedar is an exceptional wood with many characteristics. Cedar is recognized for its natural beauty and physical properties such as its distinguishing aroma, rich colour, durability, insulating properties, workability and acoustics. Cedar has exceptionally good finishing properties, accepts exterior paint, lacquer and oil. Gives long service with little maintenance and is ideal around moist areas.
Aluminium Overview	PVC Overview
The hard wearing powder coated Aluminium shutter can be used internally, but is particularly suited for external applications. A range of standard colours are available or if requested aluminium shutters can be painted to match any Resene colour from the Resene chart.	PVC shutters look like our wooden shutters but offer a longer life span and a more affordable price tag. Will not absorb moisture, delaminate, split, crack and are excellent for kitchens and bathrooms where moisture may be a problem.

Finishes

Basswood comes in a range of standard stain and painted colour options or custom colour of your choice. PVC comes in Standard paint colours or can be custom painted. Aluminium is available in standard powder coated colours only. Cedar finishes can be oiled, lacquered or painted. Colour on actual shutters may vary slightly from samples provided, due to natural colour variance in the wood species and paint age.

Finish/Colours	Painted	Stained
Basswood	White-101, Snow-105, Swiss Coffee-107, Creamy-110, Butter-120, Super White-130, Pearl White-131, Egg-shell-132, Pearl-133, Bristle Half-134, Antique White-136, White On White-137, Black-020	Nature-200, Oak-205, Rose-216, Mahogany-220, Black Walnut-230, Desert-252, Ash-253, Gumnut-254, Maple-256, Coffee Bean-258
PVC	White-101, Snow-105, Swiss Coffee-107, Creamy-110, Butter-120, Super White-130, Pearl White-131, Egg-shell-132, Pearl-133, Bristle Half-134, Antique White-136, White On White-137, Black-020 or custom painted to any Colour	N/A
Aluminium - (Powder Coated)	Pearl White-PC-1, Birch-PC-B-2, Black-PC-B-3, Silver-PC-B-4	N/A

Finish/Colours	Lacquered	Oiled	Painted
Cedar	Light to Medium Medium to Dark Natural	Light to Medium Medium to Dark Natural	Colour match to any Resene Colour Chart

Louvre Size and Tensioning Screw

Various size louvres are available with a choice of two profiles. The first is elliptical in shape, sculptured where the louvre is thicker in the middle and tapered to the front and back. An elliptical louvre is stronger than the alternative traditional flat 68mm louvre. *For technical data, refer to pages 14, 15, 16, 17, 18, 19, 20, 21.*

For Basswood shutters, we have a unique tensioning screw which is used to adjust the tension of the louvres. This comes into its own specifically for full height shutters where adjusting the tensioning screw allows the movement of louvres with ease. *For technical data, refer to page 18.*

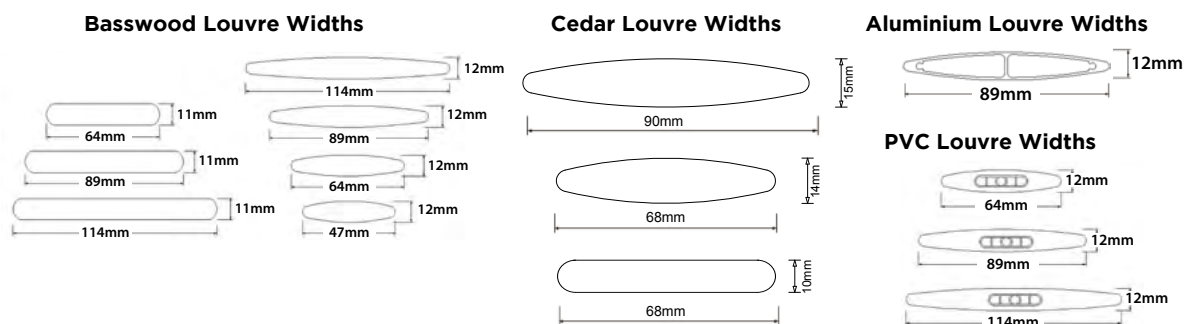

Basswood & Cedar Shutters

Introduction

Basswood and Cedar Shutters may be used for a variety of reasons: visibility and airflow, controlling the amount of sunlight that enters a room, privacy, security and the ability to enhance the aesthetics of a building or terrace access adding to practicality and mood of any interior. Window Treatment's traditional European styled Basswood & Cedar shutters are an aesthetically pleasing and versatile window management system. Cedar is recognized for its natural beauty, rich colour, durability, insulating properties and acoustics. Basswood is a hardwood which is durable, lightweight and has a fine straight grain material with an even texture, consistent colour and low resin content. Both Cedar and Basswood have good finishing properties which accept oil based paint and exterior stain for long lasting finishes.

Basswood & Cedar Shutters can be either fixed permanently in place, hinged, bi-fold or sliding depending on your preference and application. Louvres can be adjustable or fixed within the shutter frame. Full height shutters are made with a mid-rail which separates the upper and lower portions of the shutter, with operable louver shutters this gives greater control as the louvres above the mid-rail can be operated independently from the louvres below the mid-rail. A tilt bar is used for adjusting louver position and to keep louvres in uniform position. Alternatively a clear view metal tilt rod is placed on the reverse side of the shutter allowing you to adjust all louvres position by tilting one louver. This also allows for cleaner lines on the front of the shutter and helps to decrease light gap measurements on sliding shutter applications.



Quick Glance

Type		Basswood	Cedar
Louvres	Louvre Size	47.6mm (Aerofoil only), 64mm, 89mm, 114mm (Flat Blade or Aerofoil)	68mm (Flat blade), 68mm, 90mm (Aerofoil)
Tilt Bar	Tilt Bar Position Clear View	Centre, Left or Right Yes	Centre, Left or Right Yes
Style	Hinged Bi-fold Straight Sliding Fixed Louvres (ventilated) Fixed Louvres (non-ventilated) Special Shape Shutters	Yes Yes Yes Yes Yes Yes	Yes Yes Yes Yes Yes Yes
Stile Options	Square Rabbit D-mould	Yes Yes Yes	Yes Yes Yes
Motorised Option		Yes	Yes
Hardware	Tracking Systems Hardware	Yes Yes	Yes Yes
Frame Options	Stiles Mid-rail Light Stop Hang Strips L Frames Z Frames T Post U Channel Corner Post	Yes Yes Yes Yes Yes Yes Yes Yes Yes	Yes Yes Yes Yes Yes Painted Only Yes Painted Only Painted Only
Finish	Stained Oiled Lacquered Painted Powder coated	Yes No No Yes No	No Yes Yes Yes No

SPECIFICATIONS

Basswood & Cedar Shutters

Tilt Rod, Louvre Size, Louvre Style,

Tilt Rod Control Position:

Plantation

Standard position for the tilt bar control on Plantation shutters is centred within the frame. Alternatively, the tilt bar can be positioned off-centred left or right. The off-centred option is mainly used for bi-fold panels to allow the panels to fold onto each other without hitting the tilt bar. A tilt rod (in conjunction with a hooked push pole) is also used for high/out of reach and special shaped shutters.

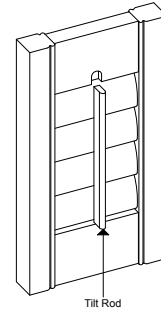

Plantation

Clear View

The Clear View control option for Basswood and Cedar shutters is a metal tilt rod rebated into the side of the louvre blade on the reverse side of the panel. This allows for cleaner lines and a clear view through the shutter once the louvres are opened or closed. The standard Clear View tilt bar position is on the hinged stile side of the louvre blades. The Clear View option is also used for sliding shutter applications as this decreases light gap measurements and allows each shutter panel to sit closer to one another reducing the depth of the shutters when stacked.

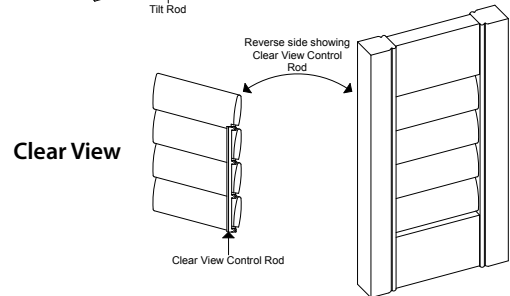

Clear View

Louvre Size and Tensioning Screw

Various size louvres are available with a choice of two profiles. The first is an aerofoil blade which is elliptical in shape (i.e. thicker in the middle and tapered to the front and back). An aerofoil louvre is stronger than the alternative traditional flat blade 68mm louvre. Note Flat blade is not available in 50mm louvre size.

For Basswood shutters, we have a unique tensioning screw which is used to adjust the tension of the louvres. This comes into its own specifically for full height shutters where adjusting the tensioning screw allows the movement of louvres with ease.

Basswood Louvre Widths

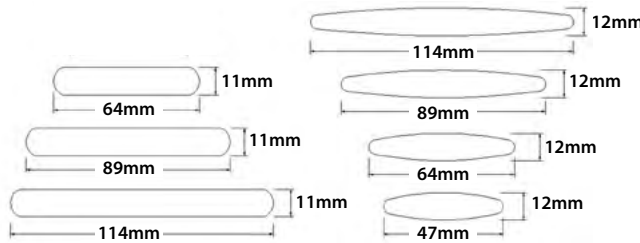

Cedar Louvre Widths

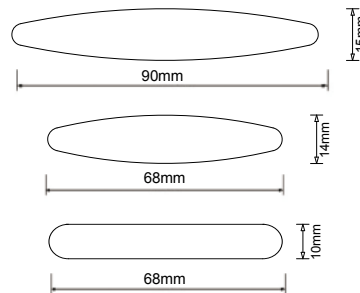

Louvre Style for Special Shape Shutters

For Basswood and Cedar special shape shutters, Window Treatments supplies 3 louvre style options. Note Flat blade is not available in 50mm louvre size.

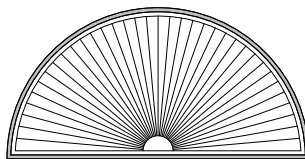

Sector 89mm
Available louvre - 89mm

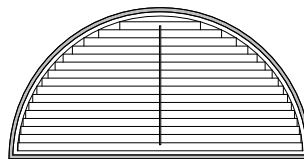

Full Open
Available louvres - 50, 64, 68, 89, 90mm

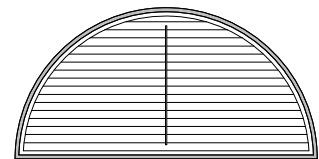

Half Open
Available louvres - 50, 64, 89mm

Type	Option	Available Louvre Size
Basswood	Sector 89	89mm
	Full Open	50mm, 64mm, 89mm
	Half Open	50mm, 64mm, 89mm

Type	Option	Available Louvre Size
Cedar	Full Open	68mm, 90mm

Basswood & Cedar Shutters

- Stile options

Stiles

Window Treatments supplies 3 stile options: Square, Rabbet, and D-mould. For light gaps, Rabbet or D-mould stiles are used to provide a light block where two panels overlap or interlock.

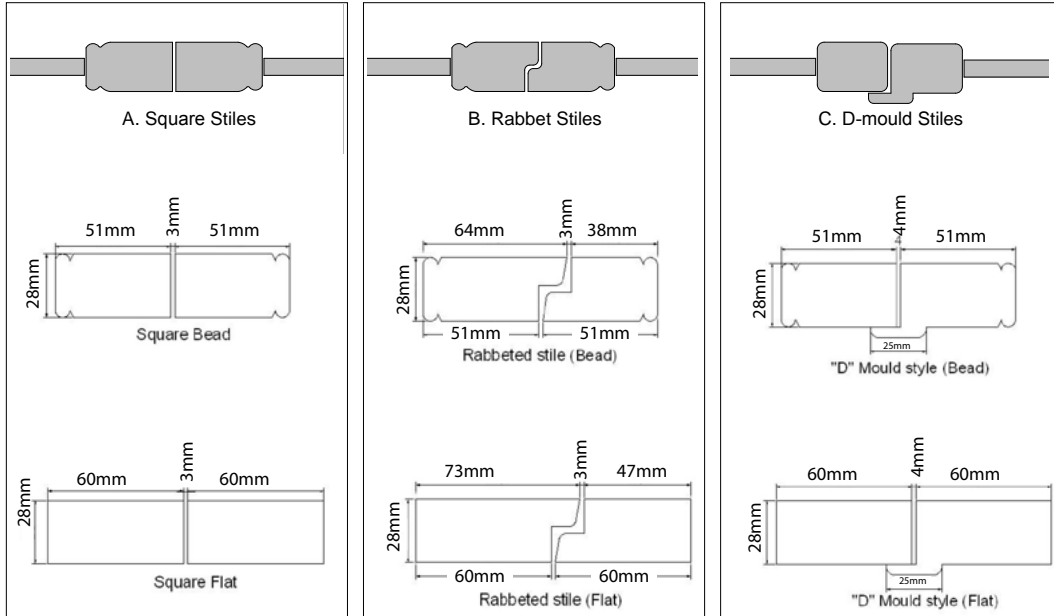

Please Note: If there is only one panel then only square stile is available. When the shutter has 2 panels connected with hinges, all stile options are available.

Square stile (Flat)



Square Stile (Bead)

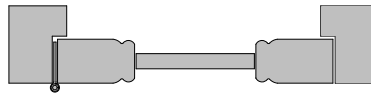

Square Stiles (Bead)



Square & Rabbet Stiles

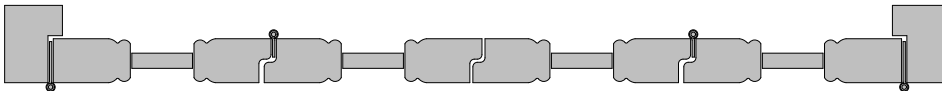

Square Stile



Square & D-mould



SPECIFICATIONS

Basswood & Cedar Shutters

- Light stop & Mount types, Square frames & Mount types

SPECIFICATIONS

Light Stop

Shutter Type	Type	Frame Options	Benefit
Basswood or Cedar	Light Stop	A4, A9,	Provides a light block where panels are hinged.

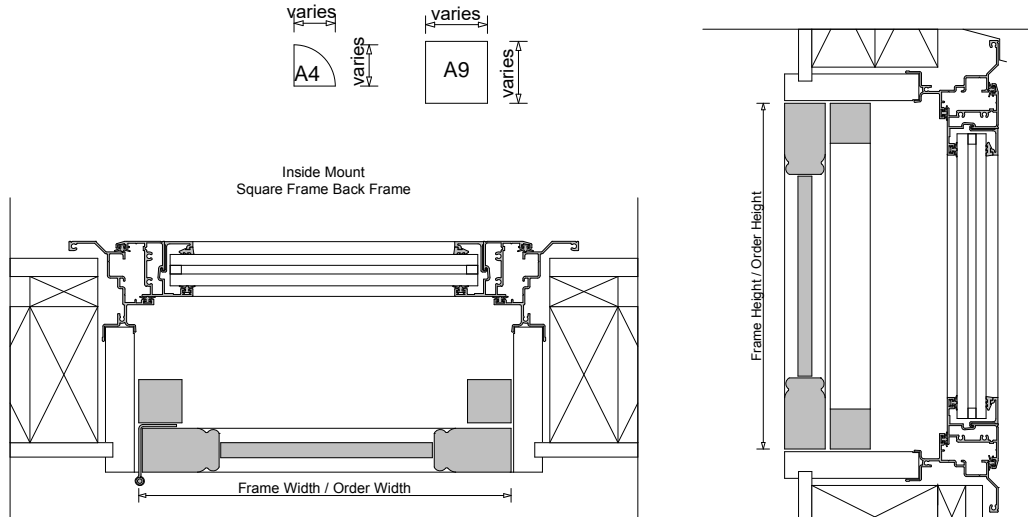

Square Frame

Shutter Type	Type	Frame Options	Benefit
Basswood or Cedar	Square Frame	B1-1 Standard, B2-1 Beaded	2 Style options are available: Standard and Beaded. Our Standard square frame is best suited to an outside mount application. Our Beaded square frame is best suited to an inside mount application. Using our Standard square frame with a Steadman hinge allows you to protrude the panel past the window opening, giving the ability to hang the shutter panel square in the frame.

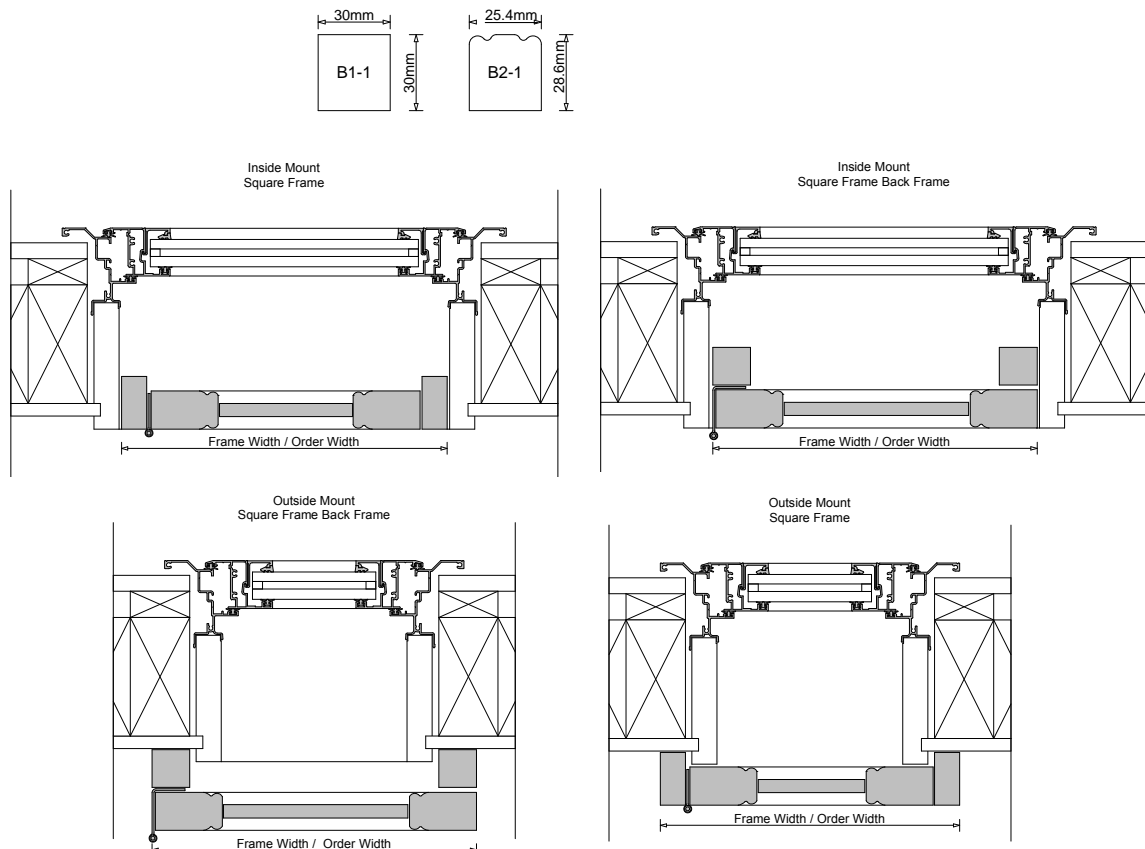

Basswood & Cedar Shutters

L Frames & Mount types, T-Posts & Mount types

L Frame

Shutter Type	Type	Frame Options	Benefit
Basswood or Cedar	L Frame	Standard, Beaded, Pre-drilled	L Frames are used to provide hanging options for single and multiple panels for outside and inside mount applications using a Butt or Steadman hinge. Using Standard and Beaded L Frames with a Steadman hinge allows you to protrude panel past window opening. This gives you the ability to hang the shutter panel square in the frame and closes light gap for flush mounted hinges. Ideal when there is no architrave in the opening.

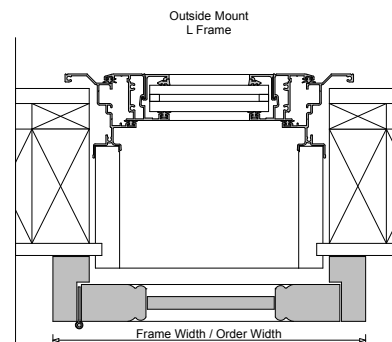
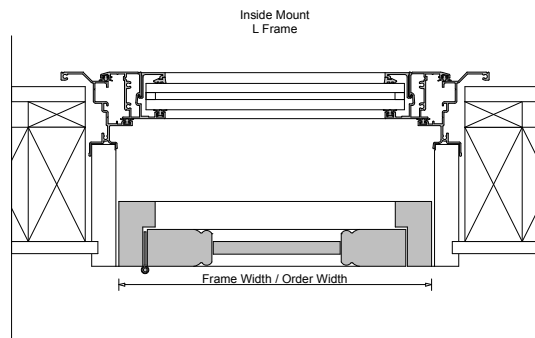
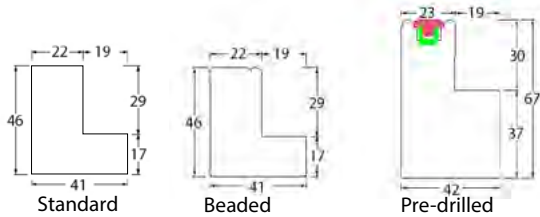

T Post

Shutter Type	Type	Frame Options	Benefit
Basswood or Cedar	T Post	T1-1 Standard (wide), T2-1 Beaded (wide), Standard (narrow), Beaded (narrow)	T Posts are used to provide hanging options for single and multiple panels for outside and inside mount applications using a Butt hinge. They give you the ability to hang the shutter panel square in the frame. The T Post closes the light gap for flush mounted hinges. Ideal when there is no architrave in the opening.

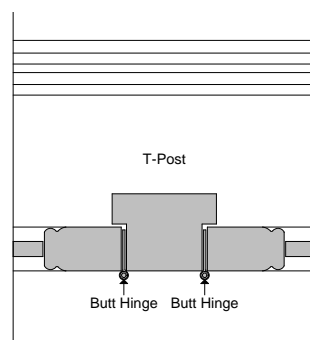
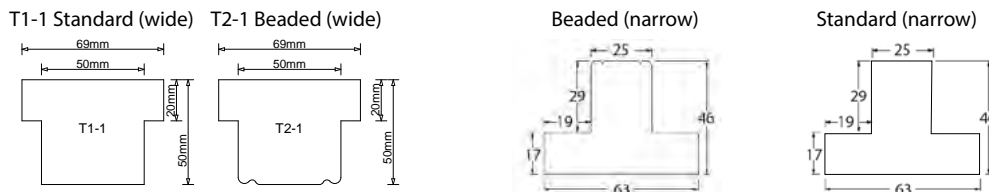

SPECIFICATIONS

Basswood & Cedar Shutters

Z Frames, U Channel, Corner Post & Mount types

SPECIFICATIONS

Z Frame

Shutter Type	Type	Frame Options	Benefit
Basswood or Cedar	Z Frame	Standard (short lipped) Standard (plain) Colonial (Basswood only)	Z Frames are used to provide hanging options for single and multiple panels within an opening. Plumbing the window frame closes the light gap for flush mounted hinges. The Z frame wraps around the reveal edge, making it ideal for covering out-of-square windows. 2 style options are available: Standard or Colonial.

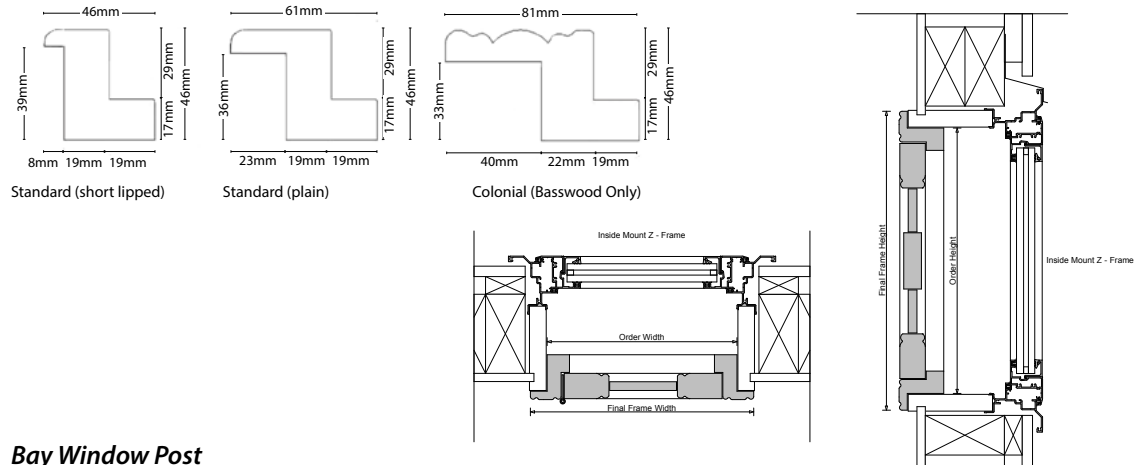

Bay Window Post

Shutter Type	Type	Frame Options	Benefit
Basswood or Cedar	Bay Window Post	Bay Window Post	Bay Corner Posts are used to provide hanging options for single and multiple panels within a bay window application. Closes light gap for flush mounted hinges. Bay Window Posts are manufactured according to the size required for each installation.

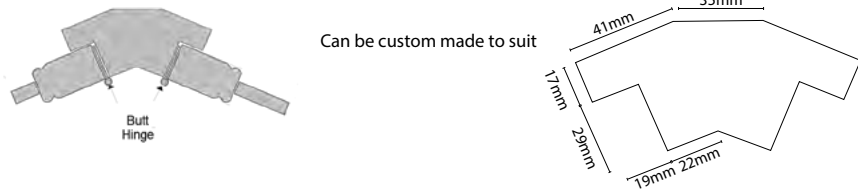

U Channel

Shutter Type	Type	Frame Options	Benefit
Basswood or Cedar	U Channel	Top, Bottom	Top and bottom 'U Channels' are ideal for incline roof applications or when access to windows is not required. The louvres can open and close and the panel can easily be removed by lifting the shutter up into the top channel and out at the bottom. To refit the reverse applies.

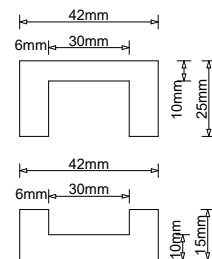

Corner Post

Shutter Type	Type	Frame Options	Benefit
Basswood or Cedar	Corner Post	CO-PO	Corner Posts are used to provide hanging options for single and multiple panels within a corner application. Closes light gap for flush mounted hinges. Corner Posts are manufactured according to the size required for each installation.

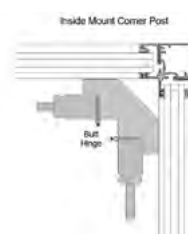
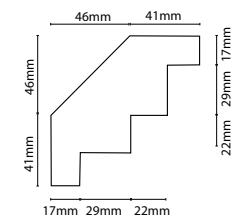

Basswood & Cedar Shutters

Panel types - Hinged, L Frame & T Post Hinged

Panel Types

Panel Types refers to the variations of each type of shutter: single panel fixed, single panel hinged, bi-folds, L Frame and T Post, straight sliding and bi-fold track variations.

The type of hinge used for a single panel, bi-fold, L Frame and T Post and for Rabbet stiles applications is a Butt hinge. However, if you require your panel to protrude past the window opening, a Steadman hinge is required hinged from a hang strip.

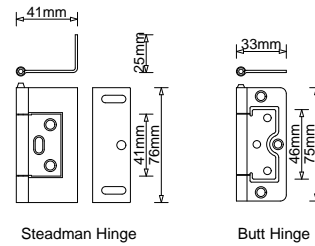

Hinged

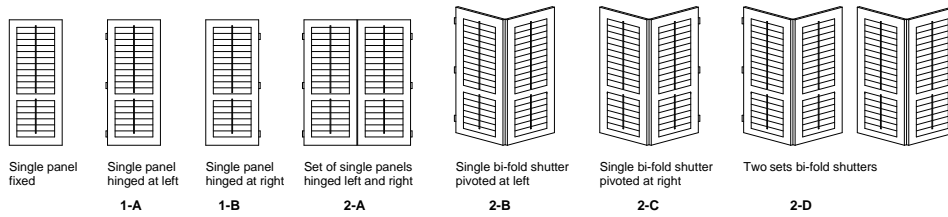

L Frame and T Post Hinged

When tracks are not feasible, L Frame and T Posts are used to provide hanging options for single and multiple panels within an opening or outside the opening window.

Basswood & Cedar (L Frame)

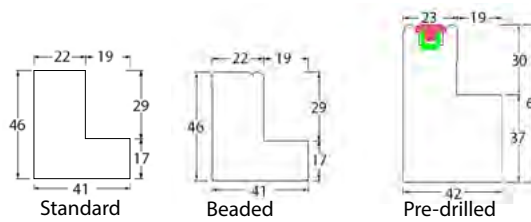

Basswood & Cedar (T Post)

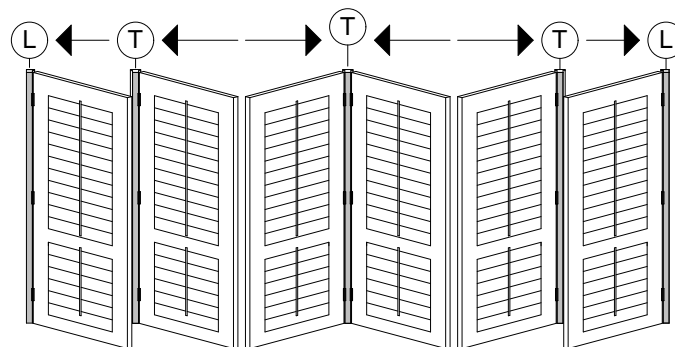
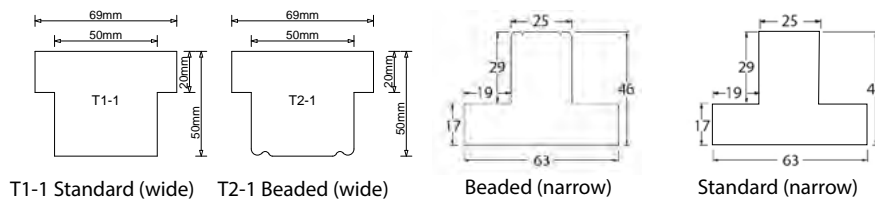

L Frame & T Post hinge options

SPECIFICATIONS

Basswood & Cedar Shutters

Panel types - Hinged, L Frame & T Post Hinged - Contd.

L Frame and T Post Hinged - cont.

Key

T means	Panel is hinged from a T Post or closes onto a T Post
L means	Panel is hinged from a L Frame or closes onto a L Frame
means	Panel direction to the right
means	Panel direction to the left

One Panel

Variations:

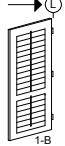
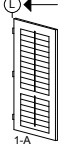

Two Panel - Individually Hinged

Variations:

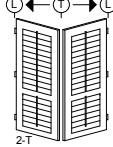
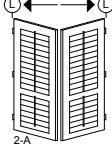

Two Panel - Bi-fold

Variations:

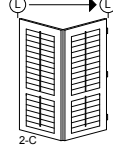
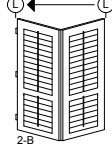

Three Panel - Individually Hinged

Variations:

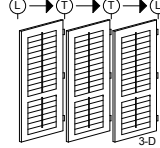
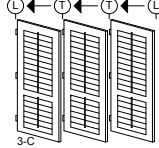
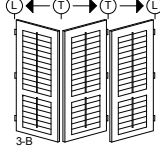
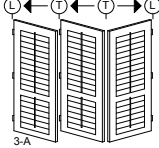

Three Panel - Bi-fold

Variations:

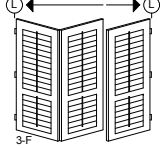
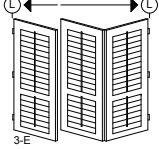

Four Panel - Individually Hinged

Variations:

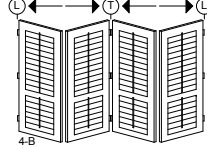
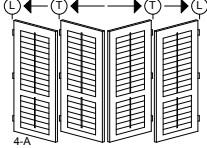

Four Panel - Bi-fold

Variations:

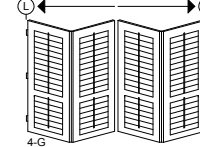
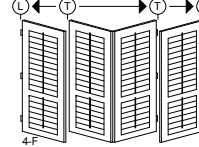
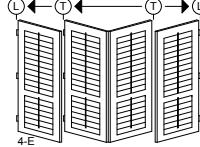
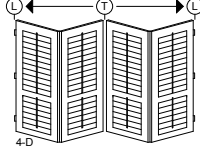
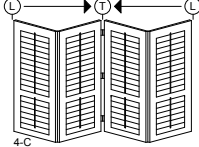

Six Panel - Individually Hinged

Variations:

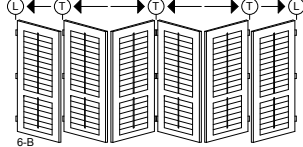
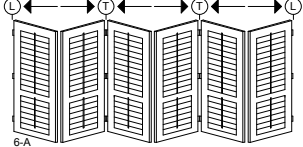

Six Panel - Bi-fold

Variations:

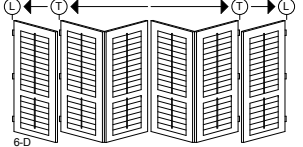
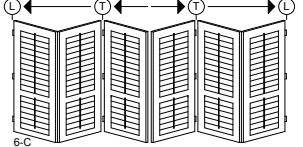

Basswood & Cedar Shutters

Fixed Shutters

Fixed Shutters

Fixed louvres are permanently open (ventilated) or permanently shut (non-ventilated). Permanently open means that there is always ventilation while blocking line of sight. Fixed louvres may be employed for a variety of reasons: to control the amount of sunlight that enters a room, to provide privacy and security, protect against weather, unwanted intrusion or damage and to enhance the aesthetics of a building.

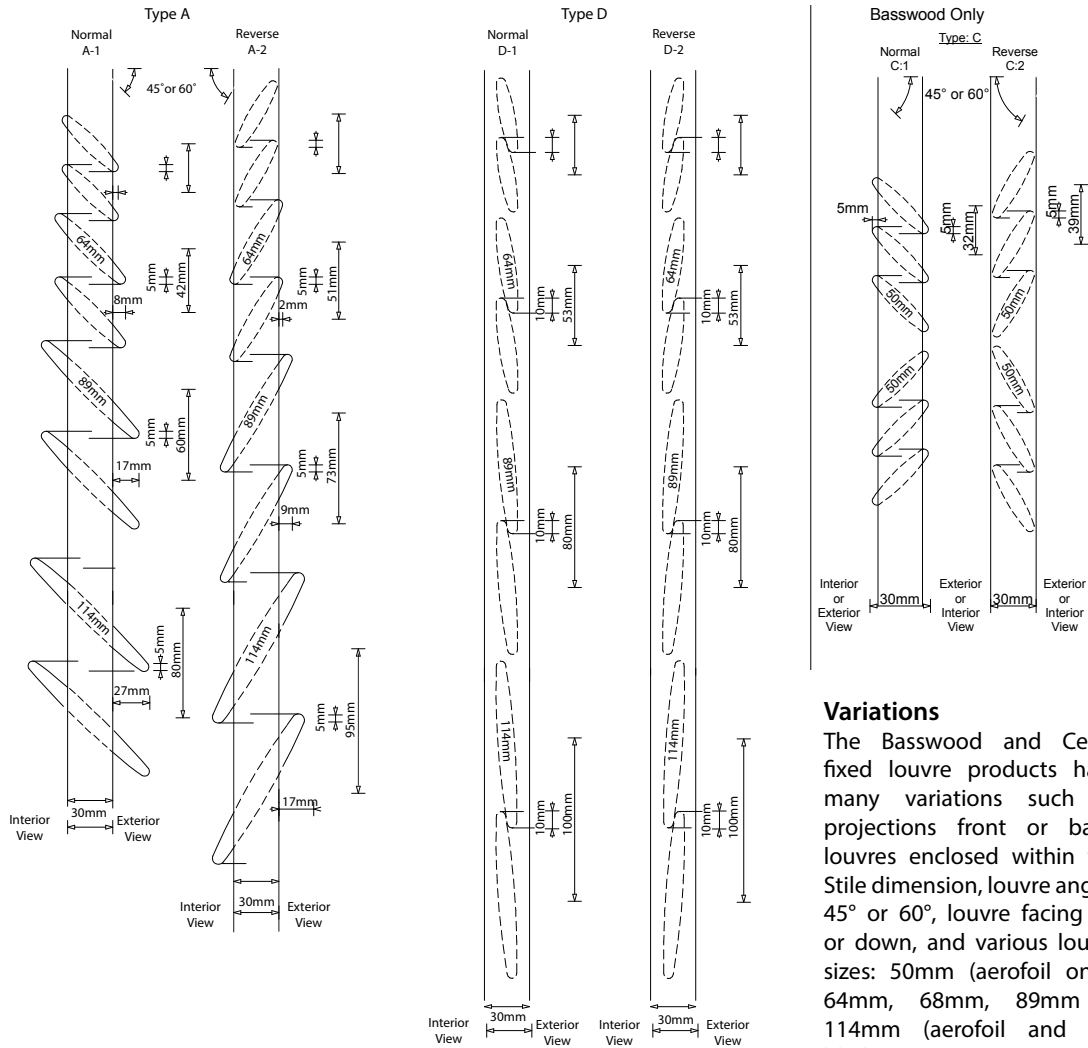

Variations

The Basswood and Cedar fixed louvre products have many variations such as projections front or back, louvres enclosed within the Stile dimension, louvre angles 45° or 60°, louvre facing up or down, and various louvre sizes: 50mm (aerofoil only), 64mm, 68mm, 89mm & 114mm (aerofoil and flat blade).

	Type A		Type C		Type D	
	Normal A-1	Reverse A-2	Normal C-1	Reverse C-2	Normal D-1	Reverse D-2
Stile (Basswood)	50 x 30mm	50 x 30mm	50 x 30mm	50 x 30mm	50 x 30mm	50 x 30mm
Stile (Cedar)	60 x 30mm	60 x 30mm			60 x 30mm	60 x 30mm
Louvres (Basswood) Aerofoil	50, 64, 89, 114mm	50, 64, 89, 114mm	50mm	50mm	50, 64, 89, 114mm	50, 64, 89, 114mm
Louvres (Basswood) Flat Blade	64, 89, 114mm	64, 89, 114mm			64, 89, 114mm	64, 89, 114mm
Louvres (Cedar)	68, 90mm	68, 90mm			68, 90mm	68, 90mm
Angles	45° or 60°	45° or 60°	45° or 60° Normal	45° or 60° Reverse	85° Normal	85° Reverse
Louvre Facing	Normal	Reverse				
Projection (Basswood)	4, 8, 17, 27mm	0, 2, 9, 17mm				
Projection (Cedar)	8, 9, 17mm	0, 3, 9mm				
Finish (Basswood)	Painted, Stained	Painted, Stained	Painted, Stained	Painted, Stained	Painted, Stained	Painted, Stained
Finish (Cedar)	Painted, Oiled or Lacquered	Painted, Oiled or Lacquered			Painted, Oiled or Lacquered	Painted, Oiled or Lacquered
Note: For Flat blade louvres (both Basswood & Cedar) add 2mm to above Projection sizes						

SPECIFICATIONS



Basswood Shutters

Plantation Specifications

Basswood Plantation Specifications

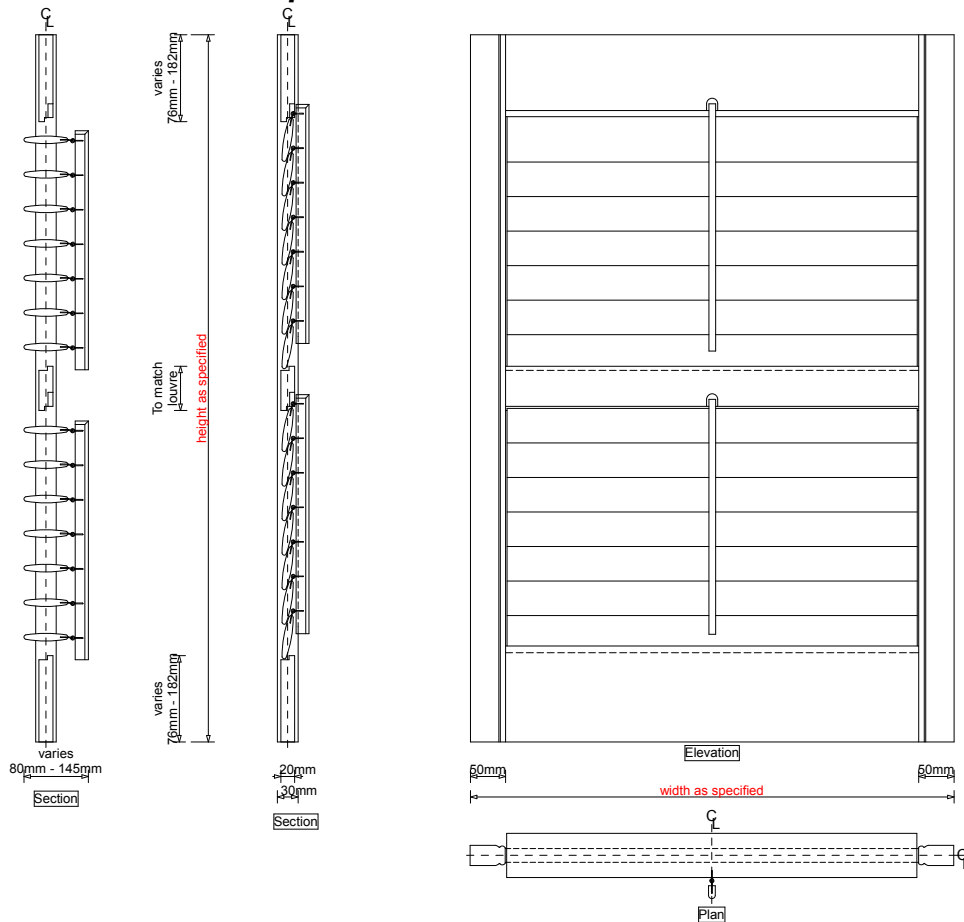

Louvre Size		
Type	Size	Options
Louvre - Aerofoil	47.6mm x 12mm	Half Open, Fixed, Ventilated, Fixed Non-Ventilated
Louvre - Aerofoil	64mm x 12mm	" " " " " " " " " "
Louvre - Aerofoil	89mm x 12mm	" " " " " " " " " "
Louvre - Aerofoil	114mm x 12mm	" " " " " " " " " "
Louvre - Flat blade	64mm x 12mm	" " " " " " " " " "
Louvre - Flat blade	89mm x 12mm	" " " " " " " " " "
Louvre - Flat blade	114mm x 12mm	" " " " " " " " " "

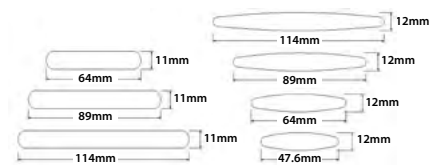

Finish	
Type	Options
Stain	Nature, Oak, Rose, Mahogany, Black walnut, Desert, Ash, Gum-nut, Maple, Coffee bean, Black, or custom colour
Painted	White, Snow, Swiss coffee, Creamy, Butter, Super white, Pearl white, Eggshell, Pearl, Bristle half, Antique white, White on white or custom painted

Width & Height Hinged	
Type	Size
Maximum Width	900mm (Single Panel hinged)
Maximum Width	650mm (Bi-fold Panel)
Maximum Width	1000mm (Sliding or Fixed)
Minimum Width	250mm (Single Panel)
Minimum Height	260mm
Maximum Height	2800mm

Stile & Rails		
Type	Size	Options
Stile	50mm x 30mm Colonial	Square, Rabbet, D-mould
Top Rail	70mm - 160mm x 20mm (varies, depends on height of panel)	
Mid Rail	64, 90, 114mm x 20mm (varies, depends on Louvre size)	
Bottom Rail	70mm - 160mm x 20mm (varies, depends on height of panel)	
Tilt Bar	19mm x 12mm centred	Left, Centre, Right Clear View

Recess	
Size	Please Note: Varies, depending on louvre size. Size of 150mm based on 114mm louvre
100mm - 150mm	

Construction	
Type	Size
Joints	Mortise and Tenon (Top, Middle, Bottom Rail)
Tension Screw & Spring for Louvre	8g x 70mm Wood Screw Stainless Steel
Louvre Dowels & Spring	Ø4 & Ø 6, 2 Plastic Dowels, Carbon Steel Spring
Eye Screw	Stainless Steel
Pin for Metal Tilt Rod	2g x 20mm, Brass
Clear View Tilt Rod	3mm x 14mm, Metal

Track Systems		
Type	Multi-fold 25	Single Run 60
Maximum Width	650mm per Panel (maximum 8 x Panels on each side)	900mm per Panel (maximum 6 x Panels on each track)
Maximum Height	3000mm	3000mm
Maximum Weight	25kg per Panel	60kg per Panel

SPECIFICATIONS

Basswood Shutters

Plantation Construction

Basswood Plantation Construction

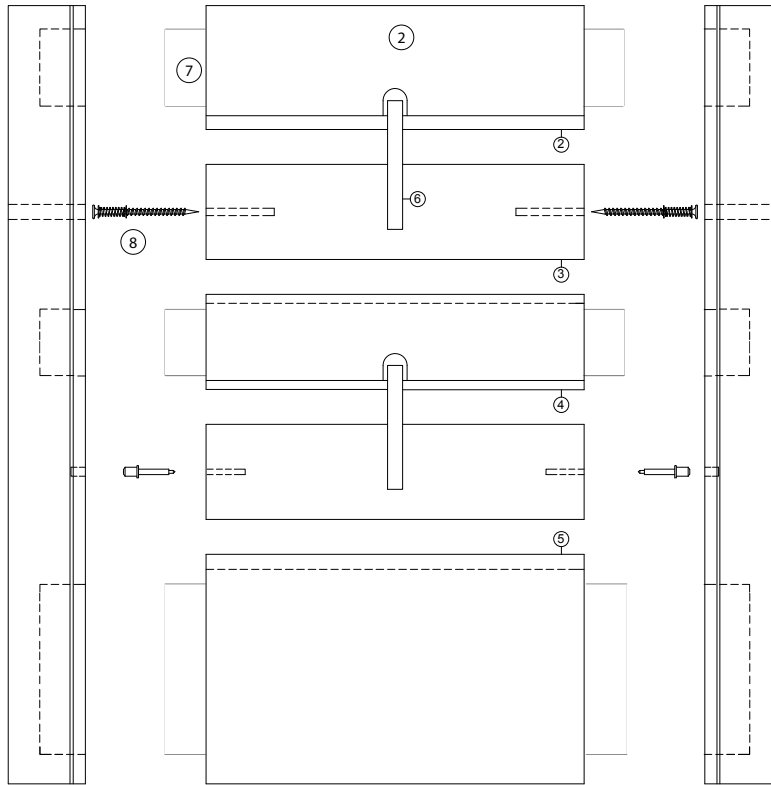

Component List

1. Stile
2. Top Rail
3. Louvre
4. Mid Rail
5. Bottom Rail
6. Tilt Bar
7. Mortise & Tenon joint
8. Tension Screw
9. Louvre Dowel
10. Eye Screw

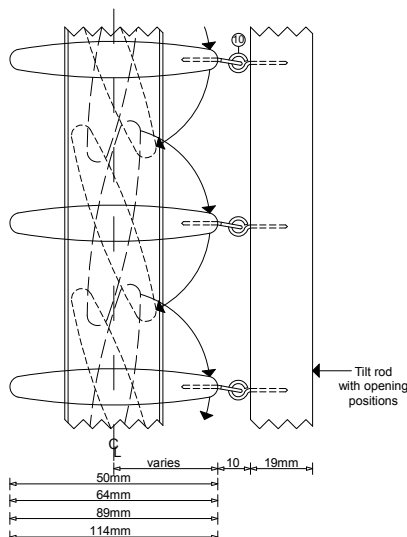
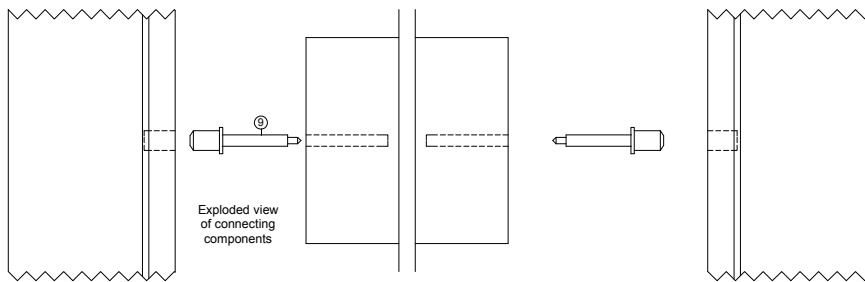

Construction

The Basswood shutter is constructed using a mortise and tenon joint to join the stiles, middle rail and bottom rail together as one frame. As the shutter height and rail size increase so does the size of the mortise and tenon joint. This strengthens, braces and prevents the frame from twisting, bowing or sagging. The louvres are mounted to the stile using the louvre dowel components, the tilt bar is then mounted to the louvres with the eye screws. The tension screw is then mounted through the stile into the louvre and tensioned. The mid rail must be used when the shutter is over 1800mm in height. This is designed to give greater strength to the shutter frame. The benefit of the mid rail option is that it allows the shutter louvres to have two sections at different angles for privacy, light and airflow. Maximum panel height for Basswood shutters with a mid rail is 2800mm, without a mid rail maximum height is 1800mm.

SPECIFICATIONS

Basswood Shutters

Plantation Clear View Construction

Basswood Clear View Construction

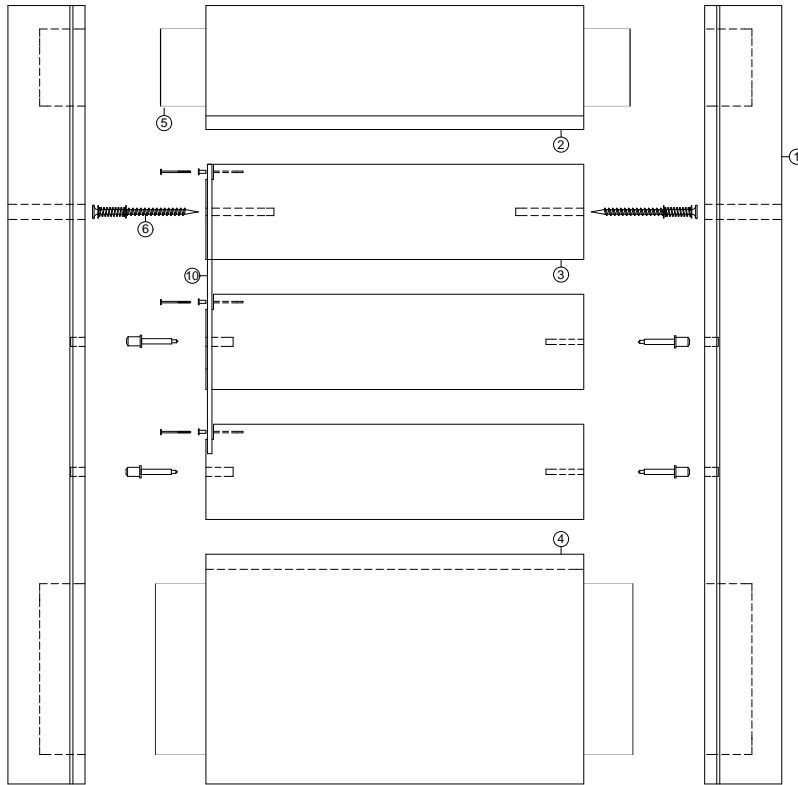

Component List

1. Stile
2. Top Rail
3. Louvre
4. Bottom Rail
5. Mortise & Tenon Joint
6. Tension Screw
7. SS Nail
8. SS Nut
9. LouvreDowel
10. Clear View Aluminium

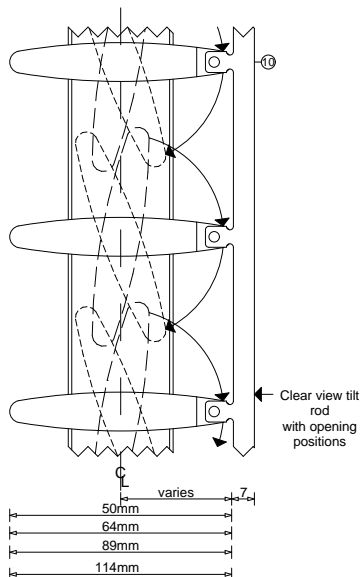
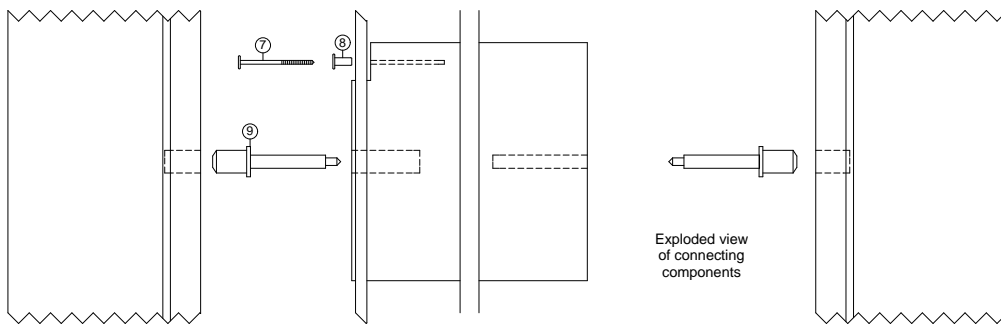

Construction

The Clear View shutter is constructed the same way as the standard Plantation shutter with the exception of the tilt bar which is replaced with the Clear View metal tilt rod option. This tilt bar is rebated into the side of the louvre blade (on the reverse side of the panel) allowing for cleaner lines with unobtrusive view through the shutter when the louvres are open or closed. This option is ideal for sliding shutter applications as this decreases light gap measurements and allows each shutter panel to sit closer to one another.

Cedar Shutters

- Cedar Plantation Specifications

Cedar Plantation Specifications

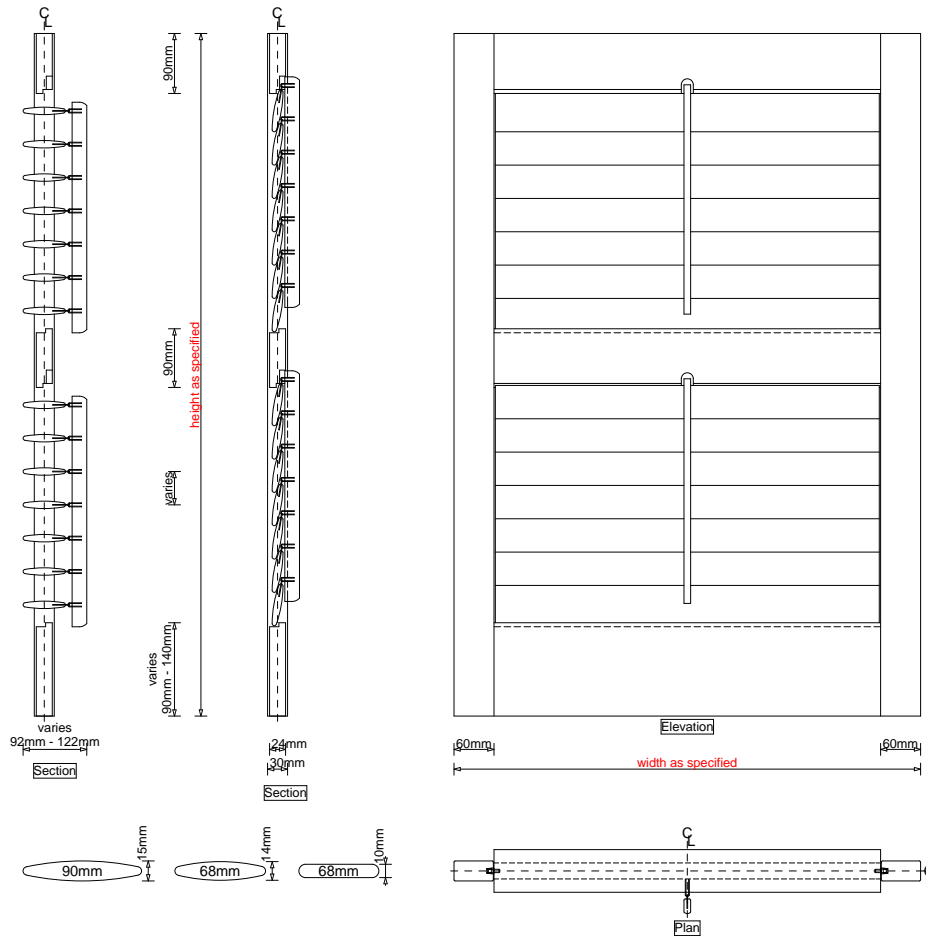

Louvre Size Type Louvre - Standard Louvre - Aerofoil Louvre - Aerofoil Size 68mm x 10mm 68mm x 14mm 90mm x 15mm Options Half Open, Fixed, Ventilated, Fixed Non-Ventilated " " " " " " " " " "		
Width & Height Hinged Type Maximum Width Maximum Width Minimum Width Minimum Height Maximum Height Size 950mm (Single Panel) 500mm (Bi-fold Panel) 250mm (Single Panel) 260mm 3000mm		Construction Type Joints Pivot Pin for Stile/Louvre Bush for Stile/Louvre Staples for Tilt Bar/Louvre Size Ø10 Dowels (Top, Middle, Bottom Rail) Ø10 x 18mm Pin (Nylon T66) Ø8 x 10mm Bush (Nylon T66) 12mm for Tilt Bar (Steel) 8mm for Louvre (Steel)
Finish Type Oiled Lacquered Painted Options Clear (polyurethane) Range standard colours or custom colour		Stile & Rails Type Stile Top Rail Mid Rail Bottom Rail Tilt Bar Size 60mm x 30mm 90mm x 24mm 90mm x 24mm 90mm - 140mm x 24mm (varies, depends on height of panel) 22mm x 12mm centred Options Square Rabbet D-mould Left, Centre, Right or Clear View
Recess Size 92mm - 122mm Please Note: Varies, depends on Louvre size. Size, 122mm based on 90mm		
Track Systems Type Maximum Width Maximum Height Maximum Weight Multi-fold 620mm per Panel (maximum 8 x Panels on each side) 3000mm 25kg per Panel Single Run 950mm per Panel (maximum 6 x Panels on each track) 3000mm 60kg per Panel		

SPECIFICATIONS

Cedar Shutters

- Cedar Plantation Construction

Cedar Plantation Construction

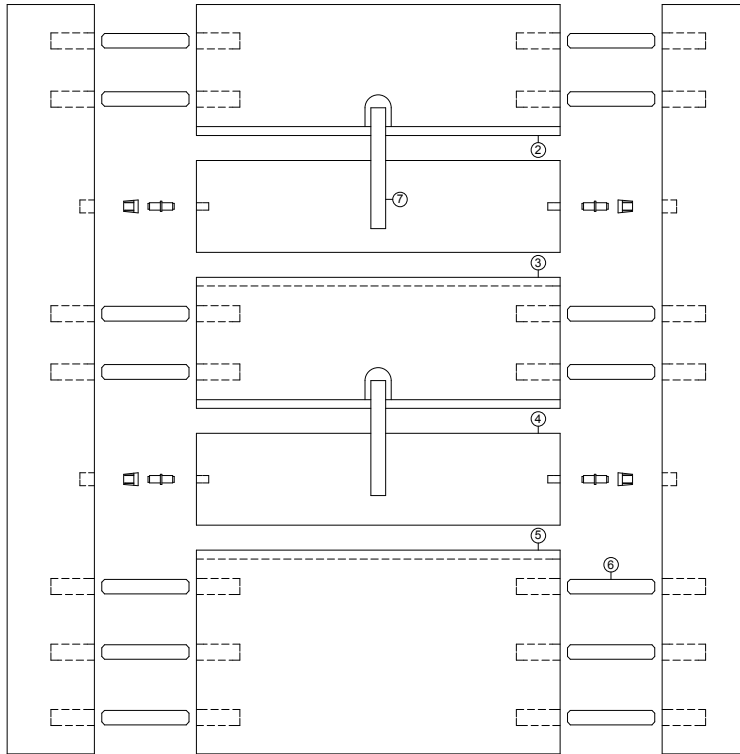

Component List

1. Stile
2. Top Rail
3. Mid Rail
4. Louvre
5. Bottom Rail
6. Dowel Joint
7. Tilt Bar
8. Pivot Bush
9. Pivot Pin
10. Staples

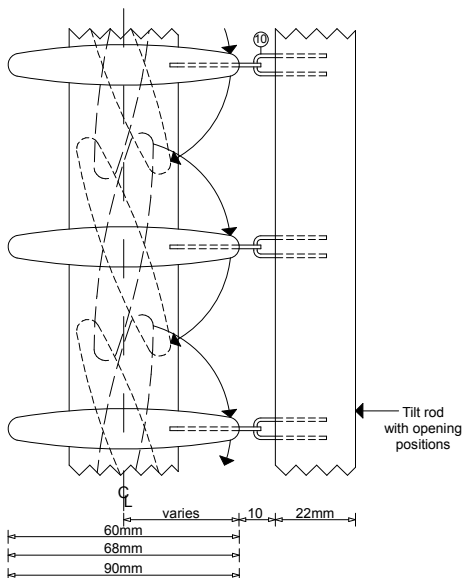
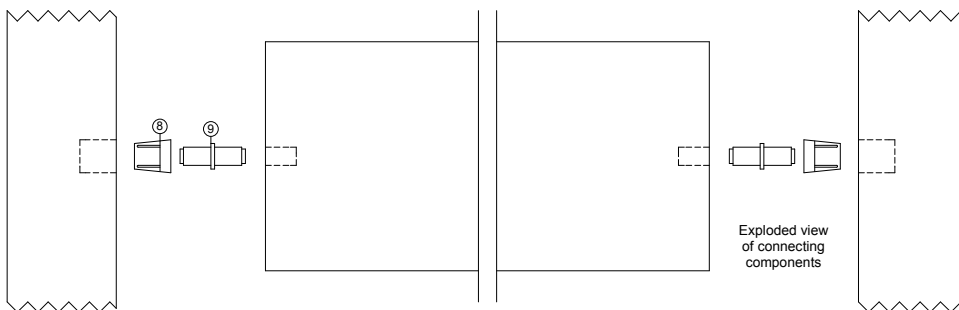

Construction

The Cedar shutter is constructed using hardwood dowelled joints and water based glue that are glued in place to join the stiles, middle rail and bottom rail together as one frame. The dowel size is Ø10mm. All rails have 2 dowels which strengthens, braces and prevents the frame from twisting, bowing or sagging. The louvres are mounted to the stile using the louvre pivot pin and stile bush components. The tilt bar is then mounted to the louvres with staples. A mid-rail must be used when the shutter is over 1500mm in height. This is designed to give greater strength to the shutter frame. Mid rails also allow the shutter louvres to have two sections at different angles for privacy, light and airflow. If the shutter is over 2950mm in height, two mid rails will be necessary.

Basswood & Cedar Shutters

- Special Shape Shutters

Special Shape Shutters

Shaped panels are designed to cover architecturally or irregular designed windows or openings. Their main attraction is the ability to follow the shape of these openings, keeping the integrity of the design.

(note: not available in Basswood 50mm Flat Blade)

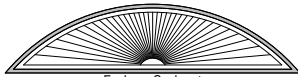

Eyebrow Sunburst
Available louvre - 89mm

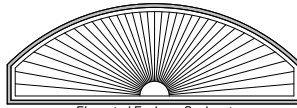

Elongated Eyebrow Sunburst
Available louvre - 89mm

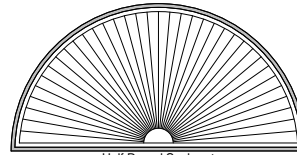

Half Round Sunburst
Available louvre - 89mm

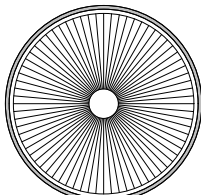

Circle Sunburst
Available louvre - 89mm

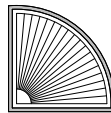

Quarter Sunburst
Available louvre - 89mm

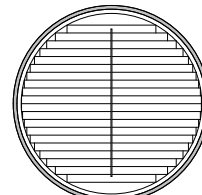

Circle with Horizontal Louvres
Available louvres - 50mm, 64mm, 89mm
Louvre open style - Full open or Half open
Tilt Rod - Plantation only

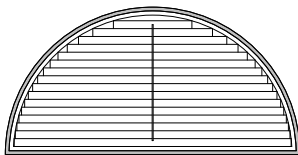

Sunburst with Horizontal Louvres
Available louvres - 50mm, 64mm, 89mm
Louvre open style - Full open or Half open
Tilt Rod - Plantation only

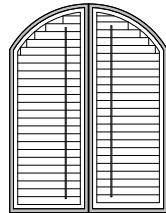

Arch
Available louvres - 50mm, 64mm, 89mm
Louvre open style - Full open or Half open
Tilt Rod - Plantation or Clear View

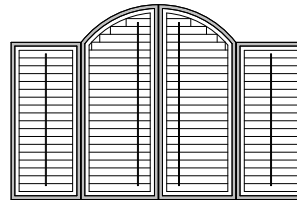

Arched Shutters with panel to both sides
Available louvres - 50mm, 64mm, 89mm
Louvre open style - Full open or Half open
Tilt Rod - Plantation or Clear View

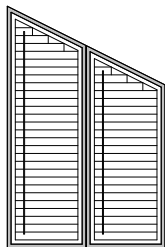

Rake
Available louvres - 50mm, 64mm, 89mm
Louvre open style - Full open or Half open
Tilt Rod - Plantation or Clear View

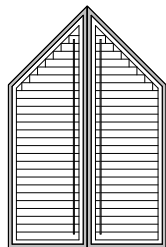

Triangle
Available louvres - 50mm, 64mm, 89mm
Louvre open style - Full open or Half open
Tilt Rod - Plantation or Clear View

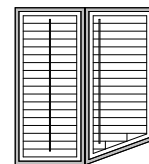

Tapered Shutters
Available louvres - 50mm, 64mm, 89mm
Louvre open style - Full open or Half open
Tilt Rod - Plantation or Clear View

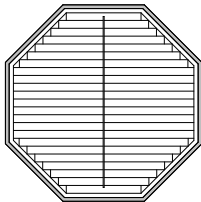

Octagon
Available louvres - 50mm, 64mm, 89mm
Louvre open style - Full open or Half open
Tilt Rod - Plantation

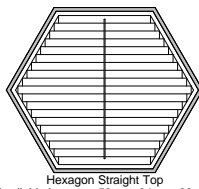

Hexagon Straight Top
Available louvres - 50mm, 64mm, 89mm
Louvre open style - Full open or Half open
Tilt Rod - Plantation

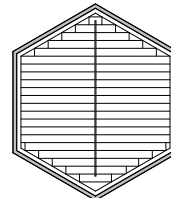

Hexagon Straight Sides
Available louvres - 50mm, 64mm, 89mm
Louvre open style - Full open or Half open
Tilt Rod - Plantation

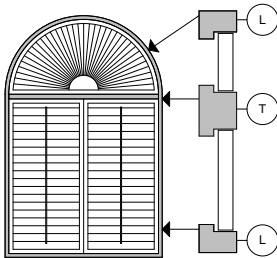

Sunburst at top with T-post and Standard Shutter at bottom
Available Louvres in bottom shutter - 50mm, 64mm, 89mm
Available louvres in Sunburst - 89mm
Bottom Tilt Rod - Plantation or Clear View

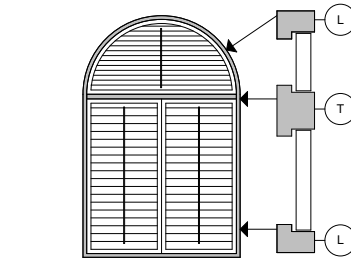

Sunburst with Horizontal Louvres at top with T-post and Standard Shutter at bottom
Available louvres in bottom shutter - 50mm, 64mm, 89mm
Available louvres in Sunburst - 89mm
Bottom Tilt Rod - Plantation or Clear View

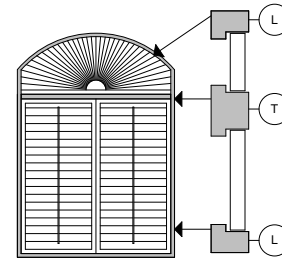

Elongated Eyebrow Sunburst at top with T-post and Standard Shutter at bottom
Available louvres in bottom shutter - 50mm, 64mm, 89mm
Available louvres in Sunburst - 89mm
Bottom Tilt Rod - Plantation or Clear View

SPECIFICATIONS

Basswood & Cedar Shutters

Hardware Technical - Tracking systems, Hinges

Hardware Overview

Tracking Systems

Window Treatments supplies two tracking systems: Multi-fold for bi-fold shutters, and Single Run for straight sliding shutters. For special applications Window Treatments can supply various track options to suit your requirements.

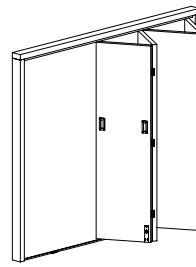

Multi-fold for Bi-fold shutters

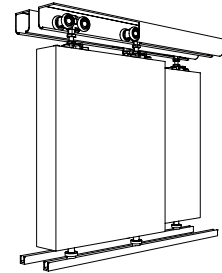

Single Run for straight sliding

Hinges

Depending on the type of shutter installation, Butt Hinge and Steadman Hinge are the standard hinges. For special applications, Window Treatments also supplies various hinge options such as Handle hinges to suit your requirements.

Butt Hinge

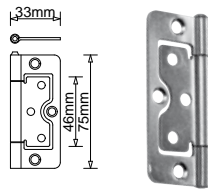

Steadman Hinge

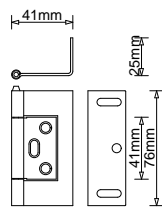

Handle Hinge

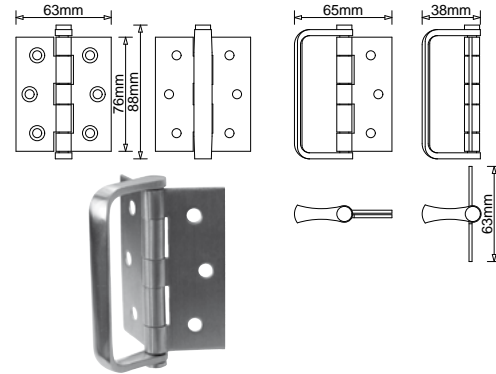

Barrel Bolt

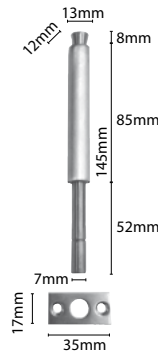

Magnetic Catch

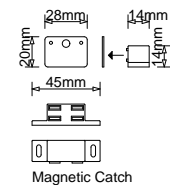

Magnetic Catch

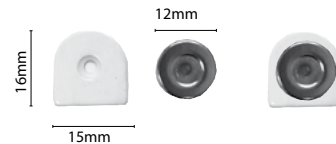

Ball Stop

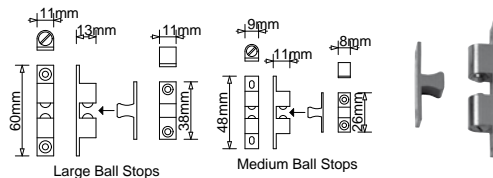

Type	Colours Available	Suitable for
Butt Hinge	Stainless Steel, Silver, Cream, White, Black, Antique Brass, Bright Brass	Square, Rabbet, T Post, L Frame
Steadman Hinge	Stainless Steel, Silver, Cream, White, Black, Antique Brass, Bright Brass	Hang Strip, protruding past window opening
Handle Hinge	Stainless Steel	Bi-fold, assists panel movement
Barrel Bolt	Stainless Steel	Bi-fold, Sliding, Panel
Ball Stops	Brass, Chrome	Securing Fixed Panel
Magnetic Catch	Brown, White, Black	Securing Bi-fold Panel

Basswood & Cedar Shutters

Hardware Technical - Sliding Single Run

Application

- Widely used in lighter commercial and industrial applications
- To cover any width of opening, any number of panels can be used
- To accommodate different building designs, panels can slide to one or both sides
- Hinged panel for easy access may be incorporated into a sliding panel
- Where panels are fitted externally, a canopy is recommended



Panel Specification

Track System: Single Run (individual Panels)

Max Panel Height: Basswood 3000mm
Cedar 2700mm

For ease of operation it is recommended that the panel width should not exceed 75% of the panel height.

Panels for interior use can be of flush construction or glazed. Panels for industrial applications should be framed, ledged and braced.

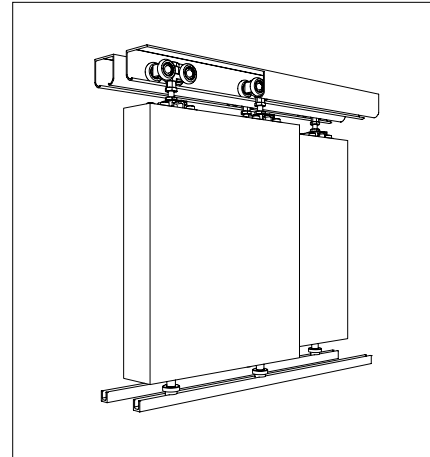

Hardware Specification

Track : 80A
Material : Aluminium
Standard lengths : 2000mm, 3000mm, 4000mm, 6000mm
Aluminium track available in mill or clear anodised finish.

Door Stop : 20DS (Stainless Steel)

Hangers (2 per door) :
Interior : No. 57EN Hamger
Hangers supplied with fixing plate and nylon tyred precision bearings. Vertical adjustment is simple and positive. Nylon tyre wheel hangers should not be used on installation involving temperatures exceeding 80°C.

Guide : No. 801S
Spring loaded guide, nylon body and tip with stainless steel shaft and spring.
Designed to slide in the No. 92 Threshold

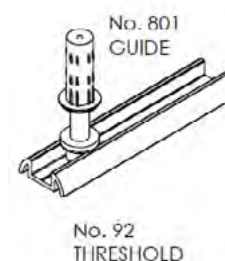
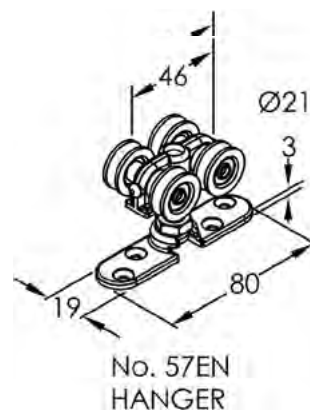
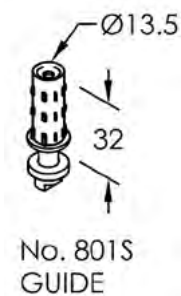
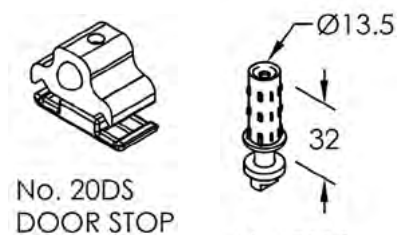

SPECIFICATIONS

Basswood & Cedar Shutters

Hardware Technical - Multi-fold

Application

- Suitable for residential and light commercial folding shutters with all panels of equal width. Panels can fold to one or both sides of the opening
- Pivot hardware enables a folding exterior shutter to be designed using equal width panels with no cutting down of the panel adjacent to the post.
- To cover any width opening, any number of folding units can be used.



Panel Specification

Track System: Multi-fold (individual leaves)

Max Leaf Height:	Basswood	2500mm
	Cedar	2500mm
Max Leaf Width:	Basswood	700mm
	Cedar	750mm

Units of up to six panels can be pivoted to each side of the opening. A guide system across the floor must be used on units of three panels or more. Floating units consist of four to six panels. Shutters should be constructed to provide secure fitting for the pivot sets, hangers, hinges and guides.

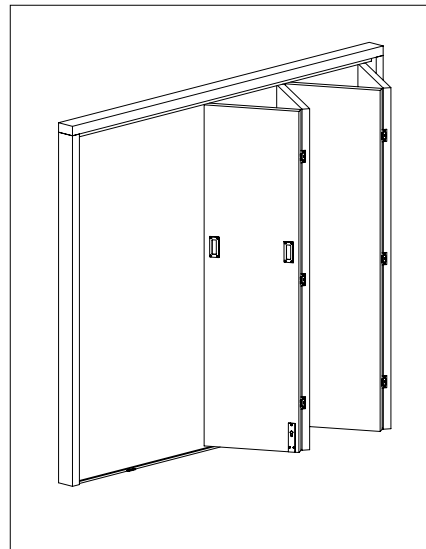

Hardware Specification

Track - punched for soffit fitting: 80A
 Material : Aluminium
 Standard lengths : 2000mm, 3000mm, 4000mm, 6000mm

Top Pivot Assembly : 21EPNC Steel, Zinc dichromated, Nylon

Bottom Pivot : 21EPNC Steel, Zinc dichromated, Nylon

Door Stop : 20DS (Stainless Steel)

Hangers : No. 57EN Hanger
 The hanger is fitted with four nylon tyred ballrace wheels. The adjustment bolt is attached to the top plate and secured in place with a blocking clip which allows easy installation. All steel parts are zinc dichromated.

Guide : No. 801S
 Spring loaded guide for use with No.92 Threshold. Guide is nylon and stainless steel.

Threshold : No. 92
 Threshold, aluminium, available in 2100mm, 3000mm, 4000mm, 6000mm

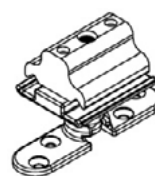

No.21EPNC
Top Pivot

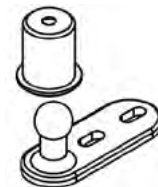

No. 21EPNC
PIVOT



No. 20DS
DOOR STOP

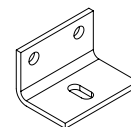

No. ADP1/60 Bracket

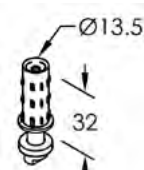

No. 801S
GUIDE



No. 92
THRESHOLD

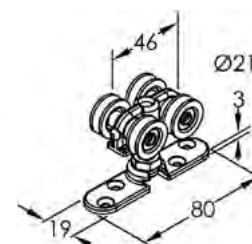

No. 57EN
HANGER

SPECIFICATIONS

Aluminium Shutters



Introduction

Window Treatment's traditional European styled Aluminium shutters are an aesthetically pleasing and versatile window management system suitable for both interior and exterior applications. The hardwearing powder coated aluminium is available in four baked enamel colours; silver, satin black, pearl white and new birch.

Aluminium shutters may be used for a variety of reasons: visibility and airflow, controlling the amount of sunlight that enters a room, privacy, security and the ability to enhance the aesthetics of a building or terrace access adding to practicality and mood of any interior or exterior area. They can be either fixed permanently in place, hinged, bi-fold or sliding depending on your preference and application. Louvres can be adjustable or fixed within the shutter frame. Full height shutters are made with a mid-rail which separates the upper and lower portions of the shutter, with operable louver shutters this gives greater control as the louvres above the mid-rail can be operated independently from the louvres below the mid-rail. A clear view metal tilt rod is used placed on the reverse side of the shutter allowing you to adjust all louvres at once by simply tilting one louver on the front side of the shutter. The clear view mechanism provides cleaner lines, preserves the view and helps to decrease light gap measurements on sliding shutter applications. Note that a front mounted tilt bar can not be used on our aluminium shutters.



Quick Glance

Type		Aluminium
Louvres	Louvre Size	89mm
Tilt Bar	Tilt Bar Position Clear View	N/A Yes
Style	Hinged Bi-fold Straight Sliding Fixed Louvres (ventilated) Fixed Louvres (non-ventilated) Special Shape Shutters	Yes Yes Yes Yes Yes No
Stile Options	Square Rabbit D-mould	Yes No Yes
Motorised Options		Yes
Hardware	Tracking Systems Hardware	Yes Yes
Frame Options	Stiles Mid-rail Light Stop Hang Strips L Frames Z Frames T Post U Channel Corner Post Bay Window Post	Yes Yes *Yes - constructed from Basswood No Yes No Yes Yes *Yes - constructed from Basswood *Yes - constructed from Basswood
Finish	Stained Oiled Lacquered Painted Powder coated	No No No No Yes

SPECIFICATIONS

Aluminium Shutters

- Tilt Rod, Louvre Size, Louvre Style,

Tilt Rod Control Position:

Clear View

The Clear View control for Aluminium shutters is a metal tilt rod rebated into the side of the louvre blade on the reverse side of the panel. This allows for cleaner lines and a clear view through the shutter once the louvres are opened or closed.

The standard Clear View tilt bar position is on the hinged stile side of the louvre blades. Aluminium shutters that are installed in hard to reach places will come with a hooked pole and have a small eyelet screwed into the bottom louvre which allows the louvres to be repositioned easily using the pole provided. The Clear View mechanism when used in sliding shutter applications decreases the light gap measurements and allows each shutter panel to sit closer to one another reducing the depth of the shutters when stacked.

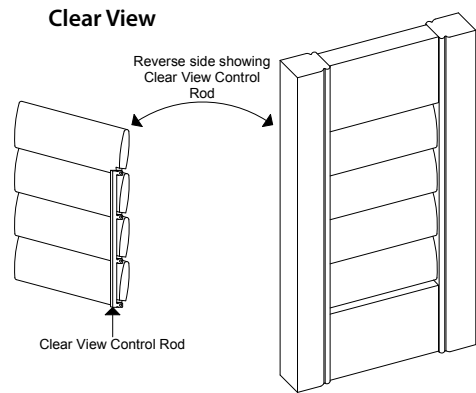

Louvre Size and Type

Aluminium shutters are available in an areofoil blade which is elliptical in shape (i.e. thicker in the middle and tapered to the front and back).

Type	Size	Thickness
Aluminium Aerofoil	89mm x 11mm	1.4mm

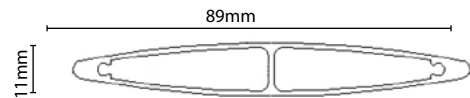

Louvre Style for Special Shape Shutters

Special shapes are not available in Aluminium shutters. Please refer to our Basswood and Cedar Shutter sections if special shapes are required.

Stiles

Window Treatments supplies 2 stile options for Aluminium shutters: Square, and D-mould. D-mould stiles are used to provide a light block where two panels overlap or interlock.

Aluminium Square Stile

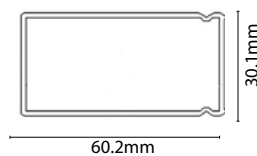

Aluminium D-mould Sti

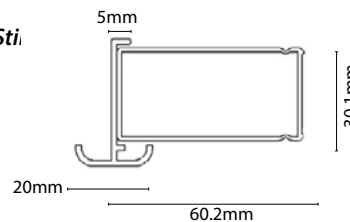

Square stile



Square Stile



Square & D-mould



Aluminium Shutters

Light stop, L frames, T frames & Mount types

Light Stop

Shutter Type	Type	Frame Options	Benefit
Aluminium	Light Stop	Varies	Provides a light block where panels are hinged. Note: constructed from Basswood

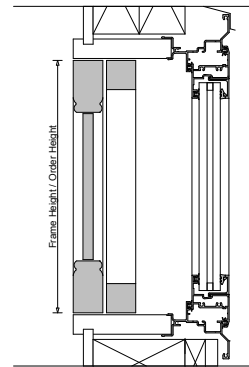
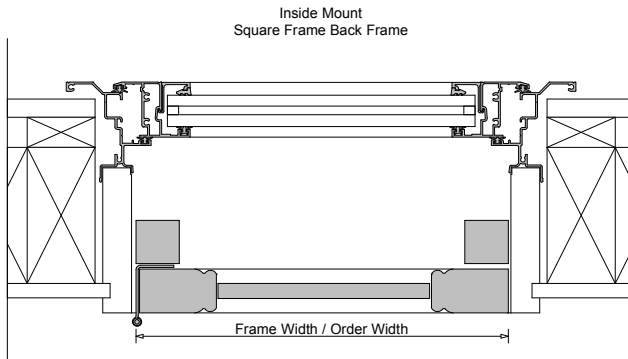

L Frame

Shutter Type	Type	Frame Options	Benefit
Aluminium	L Frame	Standard	L Frames are used to provide hanging options for single and multiple panels for outside and inside mount applications using a Butt or Steadman hinge. Using a standard frame with a Steadman hinge allows you to protrude the panel past the window opening. This gives you the ability to hang the shutter panel square in the frame and closes light gap for flush mounted hinges. Ideal when there is no architrave in the opening.

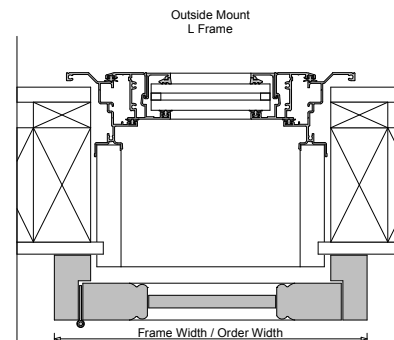
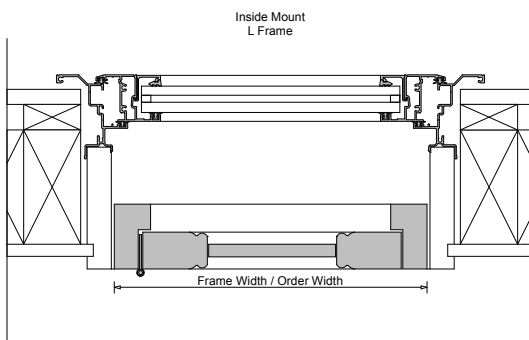
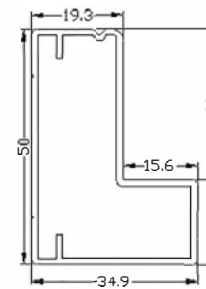

T Post

Shutter Type	Type	Frame Options	Benefit
Aluminium	T Post	Standard	T Post are used to provide hanging options for single and multiple panels for outside and inside mount applications using a Butt hinge. Gives you the ability to hang the shutter panel square in the frame. The T Post closes the light gap for flush mounted hinges. Ideal when there is no architrave in the opening. Available as Standard.

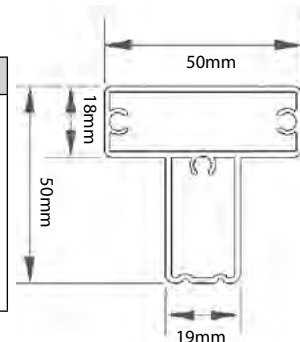

SPECIFICATIONS

Aluminium Shutters

- U Channel, Corner Post, Bay Window Post & Mount types, Panel Types

U Channel

Shutter Type	Type	Frame Options	Benefit
Aluminium	U Channel	Top, Bottom	Top and bottom 'U Channels' are ideal for incline roof applications or when access to windows is not required. The louvres can open and close and the panel can easily be removed by lifting the shutter up into the top channel and out at the bottom. To refit the reverse applies.

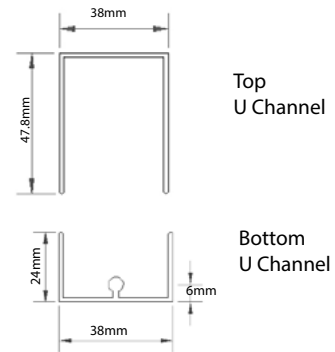

Corner Post

Shutter Type	Type	Frame Options	Benefit
Aluminium	Corner Post	Corner Post	Corner Posts are used to provide hanging options for single and multiple panels within a corner application. Closes light gap for flush mounted hinges. Corner Posts are manufactured according to the size required for each installation. Note: constructed from Basswood

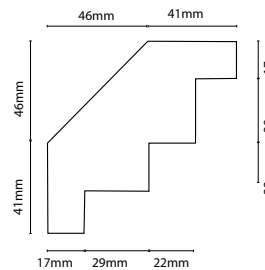
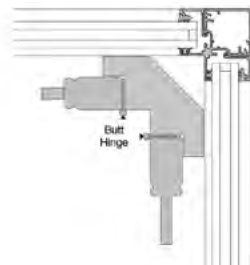

Bay Window Post

Shutter Type	Type	Frame Options	Benefit
Aluminium	Bay Window Post	Bay Window Post	Bay Corner Posts are used to provide hanging options for single and multiple panels within a bay window application. Closes light gap for flush mounted hinges. Bay Window Posts are manufactured according to the size required for each installation. Note: constructed from Basswood



Can be custom made to suit

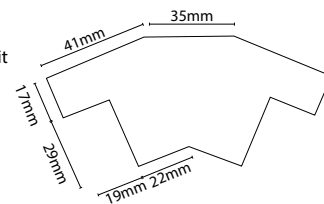

Panel Types & Hinging Options

Panel types refers to the variations of each type of shutter; single panel fixed, single panels hinged, bi-folds, L Frame, T Post, Straight sliding, and bi-foldomg variations.

The type of hinge used for a single panel, bi-fold, L frame and T post applications is a butt hinge. However if you require your panel to protrude past the window opening then a Steadman hinge is required hinged from a hang strap.

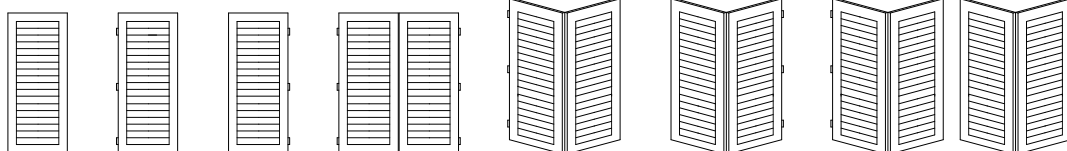
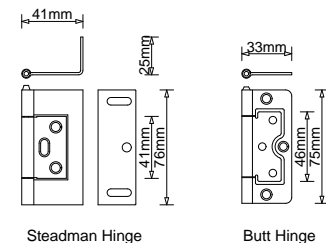

Single panel fixed

Single panel hinged at left

Single panel hinged at right

Set of single panels hinged left and right

Single bi-fold shutter pivoted at left

Single bi-fold shutter pivoted at right

Two sets bi-fold shutters

1-A

1-B

2-A

2-B

2-C

2-D

Aluminium Shutters

- Panel Types & Hinging options contd.

L Frame and T Post Hinged options

When tracks are not feasible, L frame and T Posts are used to provide options for single and multiple panels within an opening or outside the opening window (see examples below).

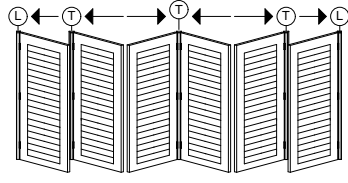

L & T Post Hinged

Key

T means	Panel is hinged from a T Post or closes onto a T Post
L means	Panel is hinged from a L Frame or closes onto a L Frame
→ means	Panel direction to the right
← means	Panel direction to the left

One Panel variations:

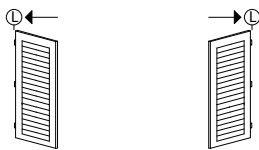

Two Panel individually hinged & Two Panel bi-fold variations:

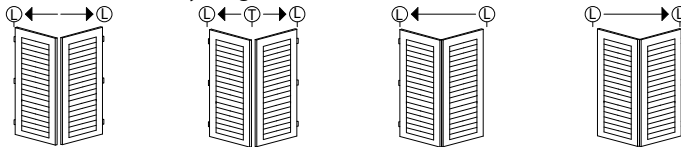

Three Panel individually hinged variations:

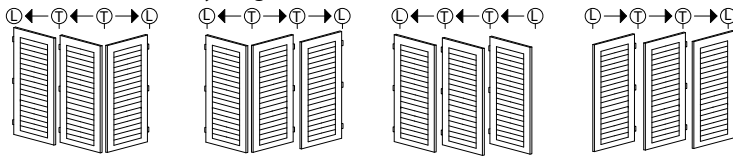

Three Panel bi-fold variations:

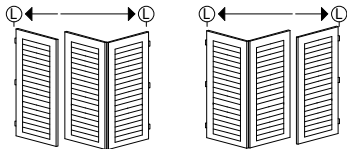

Four Panel individually hinged variations:

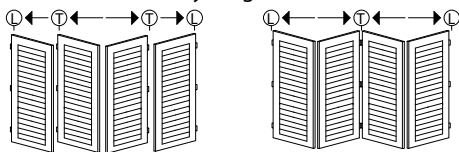

Four Panel bi-fold variations:

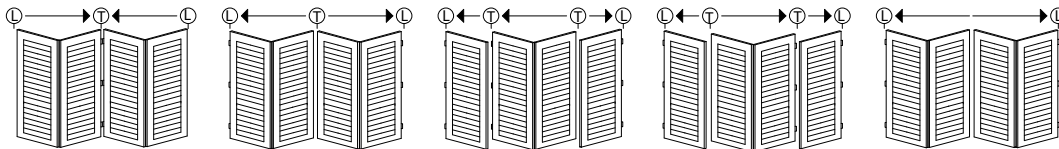

Six Panel individually hinged variations:

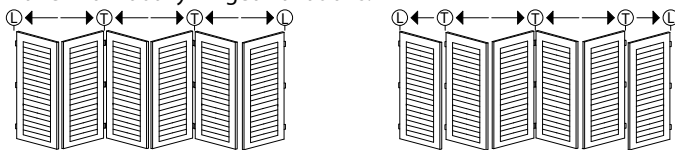

Six Panel bi-fold variations:

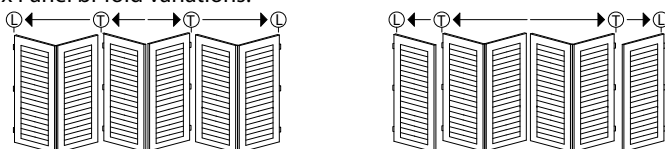

SPECIFICATIONS

Aluminium Shutters

Fixed Louvre Shutters, Overview specifications

Fixed Shutters

Fixed louvres are permanently open (ventilated - Type A) or permanently shut (non-ventilated - Type D). Permanently open means that there is always ventilation while blocking line of sight. Fixed louvres may be employed for a variety of reasons: to control the amount of sunlight that enters a room, to provide privacy and security, protect against weather, unwanted intrusion or damage and to enhance the aesthetics of a building.

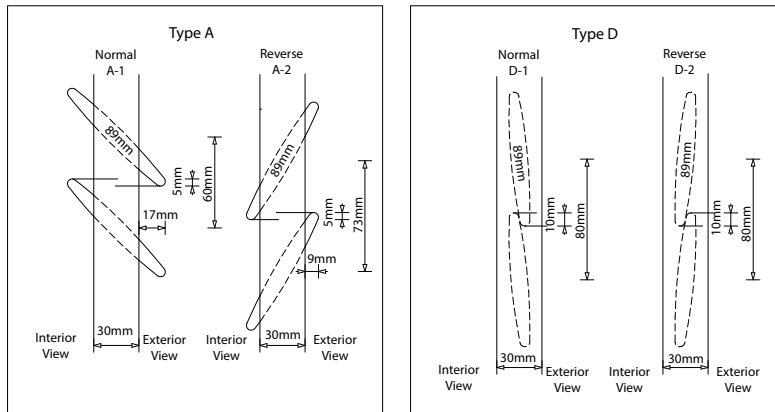

	Type A		Type D	
	Normal A-1	Reverse A-2	Normal D-1	Reverse D-2
Stile (Aluminium)	60 x 30mm	60 x 30mm	60 x 30mm	60 x 30mm
Louvres (Aluminium)	89mm	89mm	89mm	89mm
Angles	45° or 60°	45° or 60°	85°	85°
Louvre Facing	Normal	Reverse	Normal	Reverse
Projection (Aluminium)	17mm	9mm		
Finish (Aluminium)	Powder coated	Powder coated	Powder coated	Powder coated

Overview Aluminium Shutter Specifications:

Louvre Size		
Type	Size	Options
Louvre - Aerofoil	89mm x 11mm	Half Open, Fixed, Ventilated, Fixed Non-Ventilated

Width & Height Hinged	
Type	Size
Maximum Width	1100mm (Single Panel)
Maximum Width	700mm (Bi-fold Panel)
Minimum Width	300mm (Single Panel)
Minimum Height	300mm
Maximum Height	2700mm
Note: Shutters over 1800mm in height will be constructed with a mid-rail	

Finish		Stile & Rails		
Type	Colours	Type	Size	Options
Powder Coated	Silver, Satin black, Pearl white, New birch	Stile	60mm x 30mm	Square D-mould
Recess		Top Rail	25mm x 78.6mm	
Size	Louvre size 89mm	Mid Rail	25mm x 81.6mm	
122mm		Shutters over 1.800mm 1 mid-rail		
		Bottom Rail	72.4mm - 141mm x 25mm	
		(varies, depends on height of panel)		
		Tilt Rod	Rebated on reverse side of panel	Clear View only

Track Systems		
Type	Multi-fold	Single Run
Maximum Width	700mm per Panel (maximum 8 x Panels on each side)	1200mm per Panel (maximum 6 x Panels on each track)
Maximum Height	2700mm	2700mm
	Note: Shutters over 1800mm in height will be constructed with a mid-rail	Note: Shutters over 1800mm in height will be constructed with a G mid-rail

Aluminium Shutters

Hardware Technical - Tracking systems, Hinges

Hardware Overview

Tracking Systems

Window Treatments supplies two tracking systems: Multi-fold for bi-fold shutters, and Single Run for straight sliding shutters. For special applications Window Treatments can supply various track options to suit your requirements.

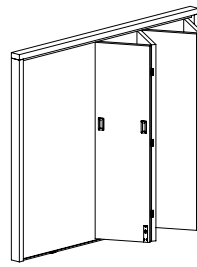

Multi-fold for Bi-fold shutters

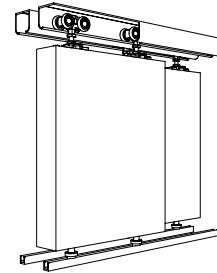

Single Run for straight sliding

Hinges

Depending on the type of shutter installation, Butt Hinge and Steadman Hinge are the standard hinges. For special applications, Window Treatments also supplies various hinge options such as Handle hinges to suit your requirements.

Butt Hinge

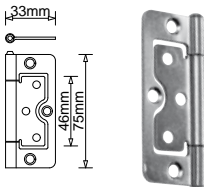

Steadman Hinge

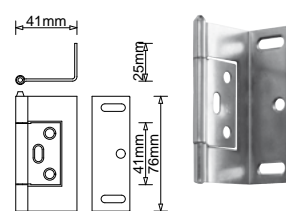

Handle Hinge

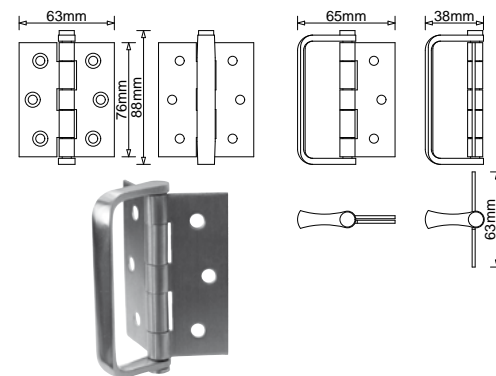

Barrel Bolt

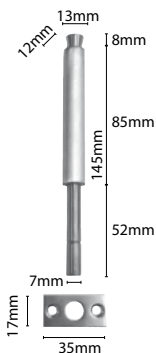

Magnetic Catch

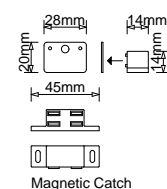

Magnetic Catch

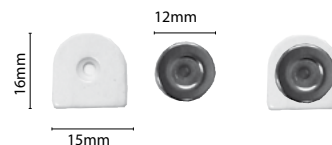

Ball Stop

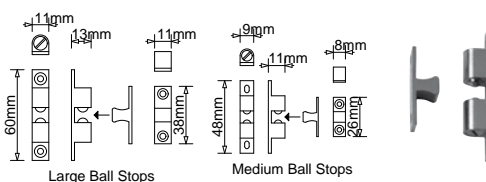

Type	Colours Available	Suitable for
Butt Hinge	Stainless Steel, Silver, Cream, White, Black, Antique Brass, Bright Brass	Square, Rabbet, T Post, L Frame
Steadman Hinge	Stainless Steel, Silver, Cream, White, Black, Antique Brass, Bright Brass	Hang Strip, protruding past window opening
Handle Hinge	Stainless Steel	Bi-fold, assists panel movement
Barrel Bolt	Stainless Steel	Bi-fold, Sliding, Panel
Ball Stops	Brass, Chrome	Securing Fixed Panel
Magnetic Catch	Brown, White, Black	Securing Bi-fold Panel

SPECIFICATIONS

Aluminium Shutters

- Hardware Technical - Sliding Single Run

Application

- Widely used in lighter commercial and industrial applications
- To cover any width of opening, any number of panels can be used
- To accommodate different building designs, panels can slide to one or both sides
- Hinged panel for easy access may be incorporated into a sliding panel
- Where panels are fitted externally, a canopy is recommended



Panel Specification

Track System: Single Run (individual Panels)

Max Panel Height: 2700mm

For ease of operation it is recommended that the panel width should not exceed 75% of the panel height.

Panels for interior use can be of flush construction or glazed. Panels for industrial applications should be framed, ledged and braced.

Aluminium panels should be constructed of box section, channel or angle framing, well braced and clad with flat or corrugated sheets.

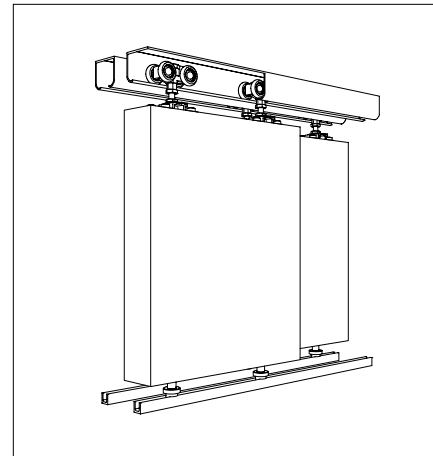

Hardware Specification

Track : 80A
 Material : Aluminium
 Standard lengths : 2000mm, 3000mm, 4000mm, 6000mm
 Aluminium track available in mill or clear anodised finish.

Door Stop : 20DS (Stainless Steel)

Hanger sets : No. 52EN/4-A
 Stainless Steel hangers are fitted with nylon wheels on precision stainless steel ball race bearings. Vertical adjustment is simple and positive.

Guide : No. 21ER-A
 With precision stainless bearing.

Channels
 Aluminium & Polypropylene : 94PPA Mill or clear anodised
 Standard lengths : 2000mm, 3000mm, 4000mm, 6000mm

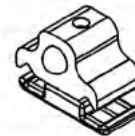

No. 20DS
DOOR STOP

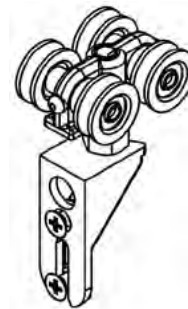

No. 52EN/4-A
INTERMEDIATE
HANGER



No. 21ER-A
END GUIDE

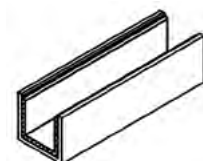

No. 94PPA
CHANNEL

SPECIFICATIONS

Aluminium Shutters

- Hardware Technical - Multi-fold

Application

- Suitable for residential and light commercial folding shutters
- Leaves can be either end folding or centre folding
- Leaves can fold to one or both sides of the opening
- Pivot hardware enables an end folding internal partition to be designed using standard width panels with no need to reduce the width of the leaf adjacent to the post.
- To cover any width opening, any number of folding units can be used.



Panel Specification

Track System: Multi-fold (individual leaves)

Max Leaf Height: 2700mm

Max Leaf Width: 700mm

Designed to suit aluminium folding screens with all panels of equal width. Panels can fold to one or both sides of the opening. Pivot hardware enables an end folding internal partition to be designed using standard width panels with no need to reduce the width of the leaf adjacent to the post. All stainless steel hardware components are located inside the aluminium stile's recess for flush and secure fitting.

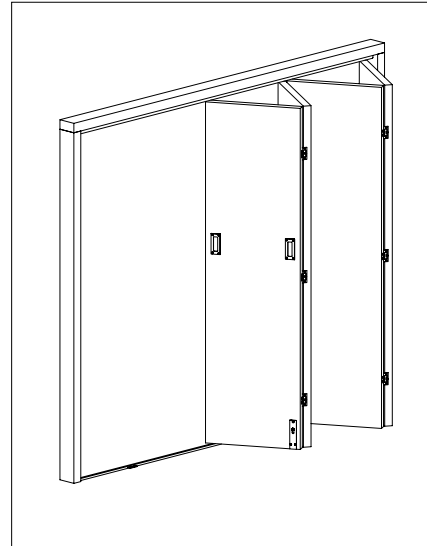

Hardware Specification

Track - punched for soffit fitting: 80A

Material : Aluminium

Standard lengths : 2000mm, 3000mm, 4000mm, 6000mm

Pivot Sets : 21EP-A

Adjustable Top & Bottom Pivot

Door Stop : 20DS (Stainless Steel)

Hanger Set :

End Hanger : 52EN-A

Intermediate Hanger : 52EN/4-A

Stainless Steel hangers are fitted with nylon wheels on precision stainless steel ball race bearings. Vertical adjustment is simple and positive.

Guide : 21ER-A

With precision Stainless steel Bearing.

Channels : 94PPA

Aluminium channel, available in 2100mm, 3000mm, 4000mm, 6000mm

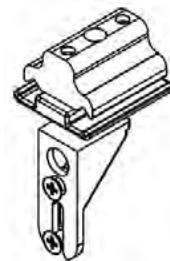

No. 21EP-A
PIVOT



No. 52EN-A
END HANGER

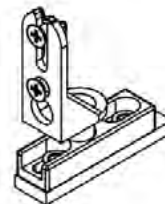

No. 21ER-A
END GUIDE

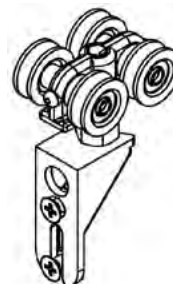

No. 52EN/4-A
INTERMEDIATE
HANGER

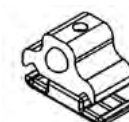

No. 20DS
DOOR STOP

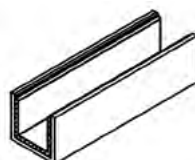

No. 94PPA
CHANNEL

SPECIFICATIONS



Aluminium Shutters

SPECIFICATIONS



PVC Shutters



Introduction

Window treatments traditional European styled PVC Shutters are the perfect interior window management system. PVC Shutters look like our Basswood shutters but offer a longer life span and more affordable price tag. PVC shutters will not absorb moisture, delaminate, split, crack and are excellent for kitchens and bathrooms where moisture may be a problem.

PVC Shutters may be used for a variety of reasons: visibility and airflow, controlling the amount of sunlight that enters a room, provide privacy and security and enhance the aesthetics of a building or terrace access adding to the practicality and mood of any interior.

PVC Shutters can either be fixed permanently in place, hinged, bi-fold or sliding depending on your preference and application. Louvres can be adjustable or fixed within the shutter frame. Full height shutters are made with a horizontal divider (mid-rail) which separates the upper and lower portions of the shutter. With operable louver shutters this gives greater control as the louvres above the mid-rail can be operated independently from the louvres below the mid-rail. A tilt bar is used for adjusting louver position and to keep louvres in uniform position. Alternatively a clear view metal tilt rod is placed on the reverse side of the shutter allowing you to adjust all louvres position by tilting one louver. This also allows for cleaner lines on the front of the shutter and helps to decrease light gap measurements on sliding shutter applications.



Quick Glance

Type		PVC
Louvre	Louvre Size	64mm, 89mm, 114mm
Tilt Bar	Tilt Bar Position Clear View	Centre, Left or Right Yes
Style	Hinged Bi-fold Straight Sliding Fixed Louvres (ventilated) Fixed Louvres (non-ventilated) Special Shape Shutters	Yes Yes Yes Yes Yes No
Stile Options	Square Rabbit D-mould	Yes Yes Yes
Motorises Options		Yes
Hardware	Tracking Systems Hardware	Yes Yes
Frame Options	Stiles Mid-rail Light Stop Hang Strips L Frames Z Frames T Post U Channel Corner Post Bay Window Post	Yes Yes * Yes - constructed from Basswood * Yes - constructed from Basswood Yes Yes Yes * Yes - constructed from Basswood * Yes - constructed from Basswood * Yes - constructed from Basswood
Finish	Stained Oiled Lacquered Painted Powder coated	No No No Yes, Standard colours or custom colours No

SPECIFICATIONS

PVC Shutters

- Tilt Rod, Louvre Size, Louvre Style,

SPECIFICATIONS

Tilt Rod Control Position:

Plantation

Standard position for the tilt bar control on Plantation shutters is centred within the frame. Alternatively, the tilt bar can be positioned off-centred left or right. The off-centred option is mainly used for bi-fold panels to allow the panels to fold onto each other without hitting the tilt bar. A tilt rod (in conjunction with a hooked push pole) is also used for high/out of reach and special shaped shutters.

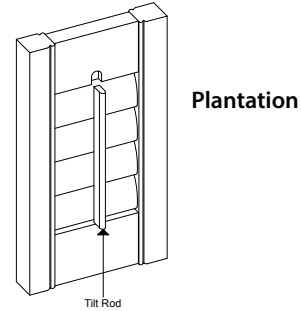

Clear View

The Clear View control option for PVC shutters is a metal tilt rod rebated into the side of the louvre blade on the reverse side of the panel. This allows for cleaner lines and a clear view through the shutter once the louvres are opened or closed. The standard ClearView tilt bar position is on the hinged stile side of the louvre blades. The Clear View option is also used for sliding shutter applications as this decreases light gap measurements and allows each shutter panel to sit closer to one another reducing the depth of the shutters when stacked.

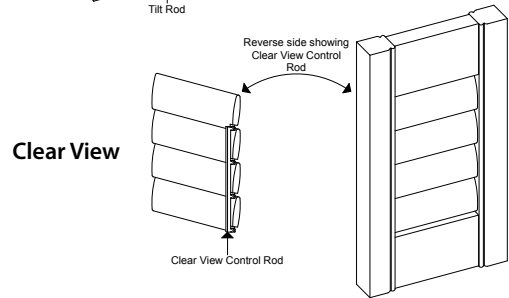

Louvre Size and Type

PVC shutters are available in three sizes of areofoil blade which is elliptical in shape (i.e. thicker in the middle and tapered to the front and back). Louvre blades are reinforced with aluminium inserts.

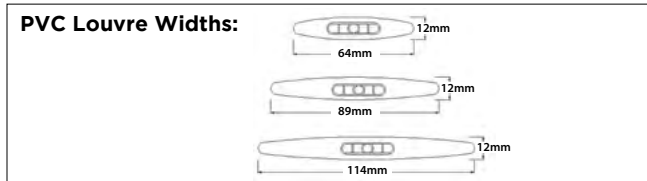

Louvre Style for Special Shape Shutters

Special shapes are not available in PVC shutters. Please refer to our Basswood and Cedar Shutter sections if special shapes are required.

Stiles

Window Treatments supplies three stile options for PVC shutters: Square, Rabbet and D-mould. D-mould stiles are used to provide a light block where two panels overlap or interlock. PVC stiles are reinforced with aluminium inserts.

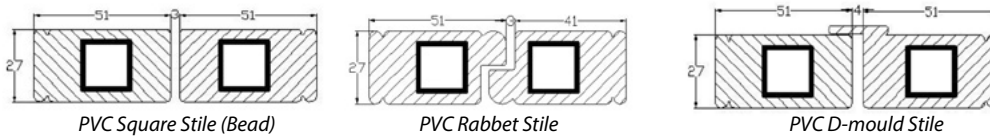

Square Stiles (Bead)



Square & Rabbet Stiles

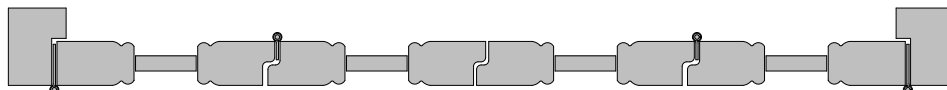

Square & D-mould



PVC Shutters

- Light stop, L frames, T frames & Mount types

Light Stop

Shutter Type	Type	Frame Options	Benefit
PVC	Light Stop	A4, A9, mm Varies Note: constructed from Basswood not PVC	Provides a light block where panels are hinged.

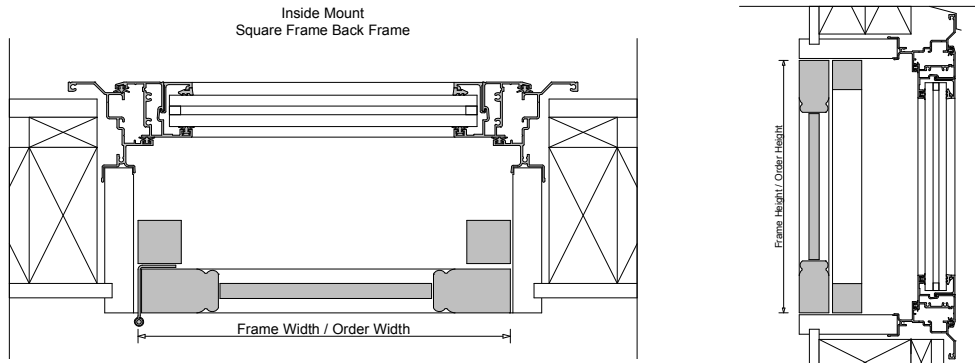
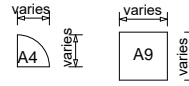

L Frame

Shutter Type	Type	Frame Options	Benefit
PVC	L Frame	Beaded (standard - PVC) or Flat (constructed from Basswood)	L Frames are used to provide hanging options for single and multiple panels for outside and inside mount applications using a Butt or Steadman hinge. Using a Beaded standard frame or Flat frame with a Steadman hinge allows you to protrude the panel past the window opening. This gives you the ability to hang the shutter panel square in the frame and closes the light gap for flush mounted hinges. Ideal when there is no architrave in the opening.

Beaded (standard - PVC)

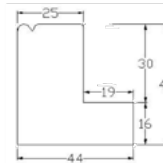

Flat (constructed from Basswood)

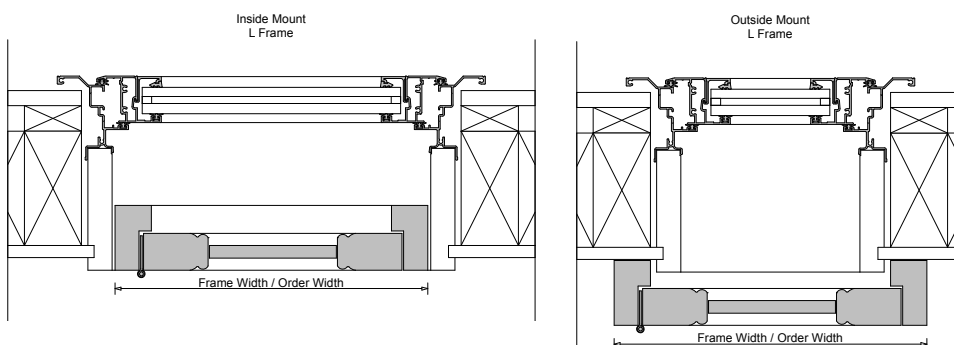
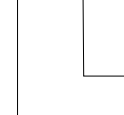

T Post

Shutter Type	Type	Frame Options	Benefit
PVC	T Post	Beaded (standard - PVC) or Flat (constructed from Basswood)	T Posts are used to provide hanging options for single and multiple panels for outside and inside mount applications using a Butt hinge. Gives you the ability to hang the shutter panel square in the frame. The T Post closes the light gap for flush mounted hinges. Ideal when there is no architrave in the opening. 2 options Beaded or Flat.

Beaded (standard - PVC)



Flat (constructed from Basswood)

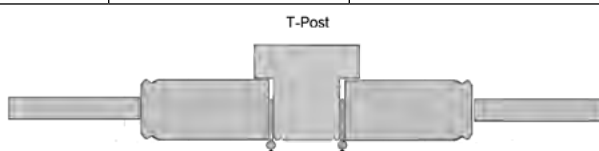
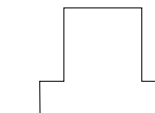

SPECIFICATIONS

PVC Shutters

Z Frame, U Channel, Corner Post, Bay Window Post & Mount types

SPECIFICATIONS

Z Frame

Shutter Type	Type	Frame Options	Benefit
PVC	Z Frame	TP Plain TP Colonial TP Fancy TP Texas	Z Frames are used to provide hanging options for single and multiple panels within an opening. Plumbing the window frame closes the light gap for flush mounted hinges. The Z frame wraps around the reveal edge, making it ideal for covering out-of-square windows. 4 style options are available

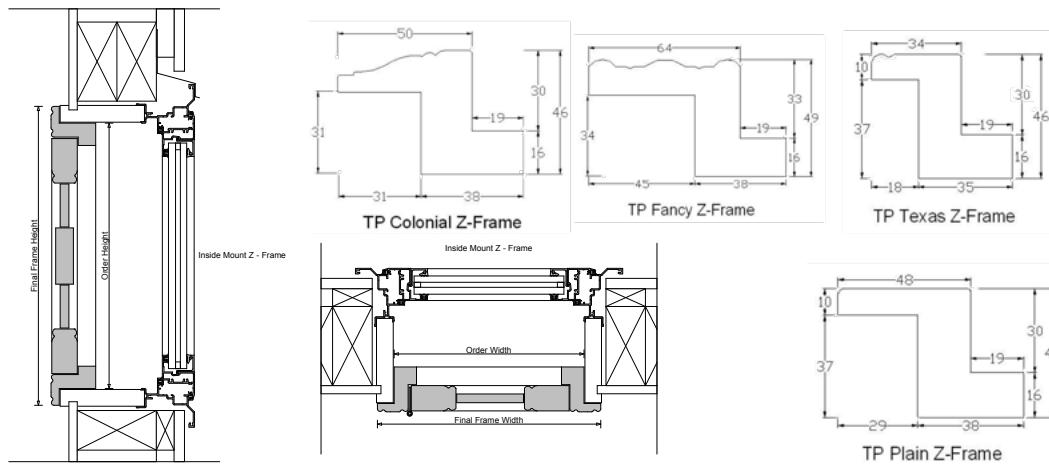

U Channel

Shutter Type	Type	Frame Options	Benefit
PVC	U Channel	Top, Bottom	Top and bottom 'U Channels' are ideal for incline roof applications or when access to windows is not required. The louvres can open and close and the panel can easily be removed by lifting the shutter up into the top channel and out at the bottom. To refit the reverse applies. Note: U Channels are constructed from Basswood not PVC

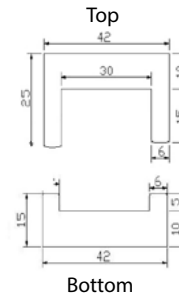

Corner Post

Shutter Type	Type	Frame Options	Benefit
PVC	Corner Post	Corner Post	Corner Posts are used to provide hanging options for single and multiple panels within a corner application. Closes light gap for flush mounted hinges. Corner Posts are manufactured according to the size required for each installation. Note: Corner posts are constructed from Basswood not PVC

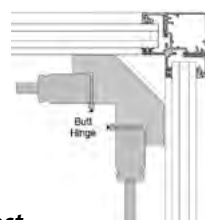

All measurements vary depending on application

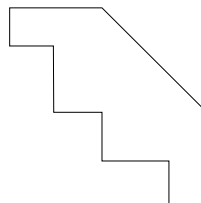

Bay Window Post

Shutter Type	Type	Frame Options	Benefit
Aluminium	Bay Window Post	Bay Window Post	Bay Corner Posts are used to provide hanging options for single and multiple panels within a bay window application. Closes light gap for flush mounted hinges. Bay Window Posts are manufactured according to the size required for each installation. Note: Bay window posts are constructed from Basswood not PVC



All measurements vary depending on application

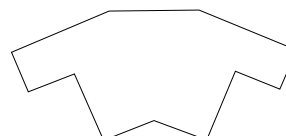

PVC Shutters

- Panel types - Hinged, L Frame & T Post Hinged

Panel Types

Panel Types refers to the variations of each type of shutter: single panel fixed, single panel hinged, bi-folds, L Frame and T Post, straight sliding and bi-fold track variations.

The type of hinge used for a single panel, bi-fold, L Frame and T Post and for Rabbet stiles applications is a Butt hinge. However, if you require your panel to protrude past the window opening, a Steadman hinge is required hinged from a hang strip.

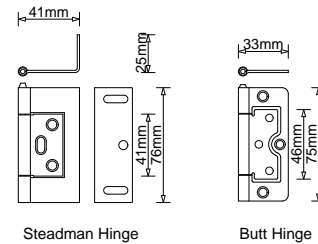

Hinged

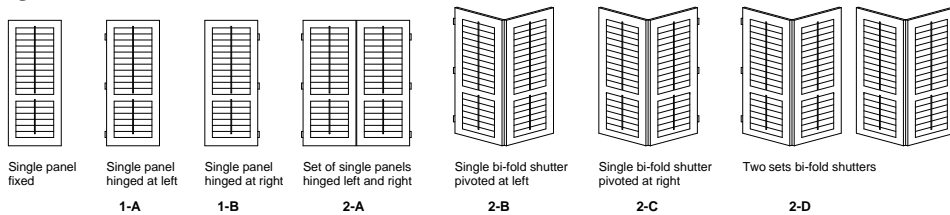

L Frame and T Post Hinged options

When tracks are not feasible, L frame and T Posts are used to provide options for single and multiple panels within an opening or outside the opening window (see examples below).

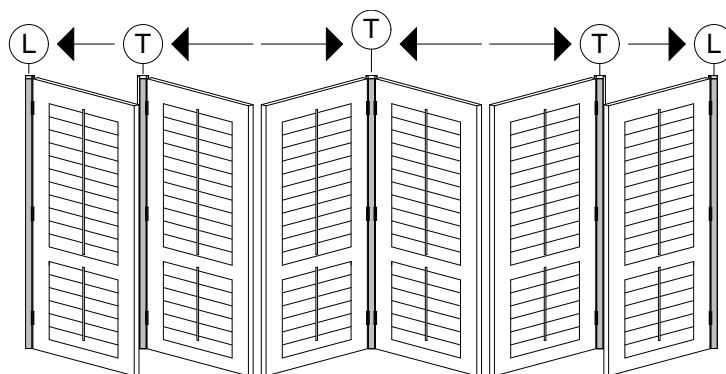
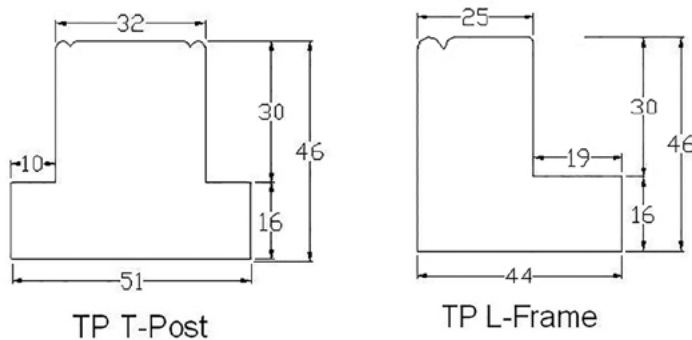

SPECIFICATIONS

PVC Shutters

- Panel types - Hinged, L Frame & T Post Hinged - Contd.

L Frame and T Post Hinged - cont.

Key

T means	Panel is hinged from a T Post or closes onto a T Post
L means	Panel is hinged from a L Frame or closes onto a L Frame
→ means	Panel direction to the right
← means	Panel direction to the left

One Panel

Variations:



Two Panel - Individually Hinged

Variations:

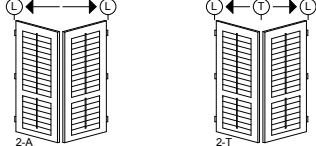

Two Panel - Bi-fold

Variations:

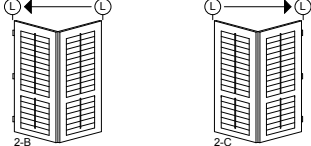

Three Panel - Individually Hinged

Variations:

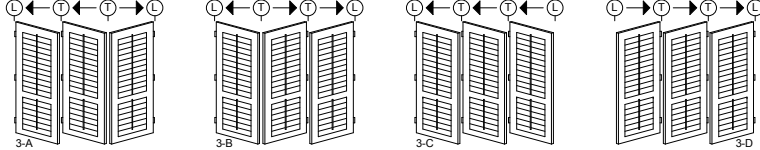

Three Panel - Bi-fold

Variations:

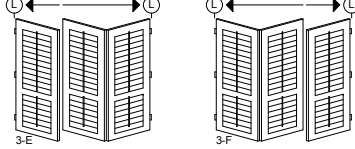

Four Panel - Individually Hinged

Variations:

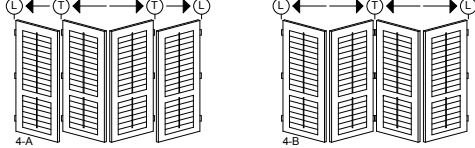

Four Panel - Bi-fold

Variations:

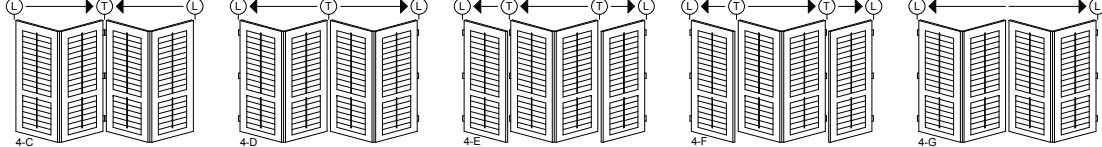

Six Panel - Individually Hinged

Variations:

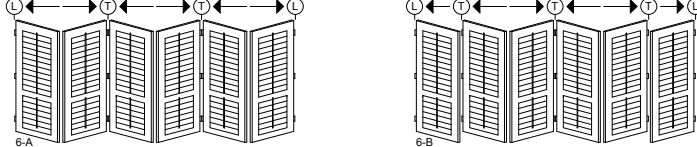

Six Panel - Bi-fold

Variations:

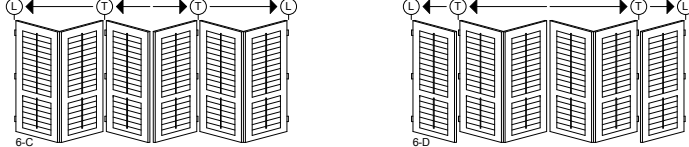

SPECIFICATIONS

PVC Shutters

Fixed Louvre Shutters, Overview specifications

Fixed Shutters

Fixed louvres are permanently open (ventilated - Type A) or permanently shut (non-ventilated - Type D). Permanently open means that there is always ventilation while blocking line of sight. Fixed louvres may be employed for a variety of reasons: to control the amount of sunlight that enters a room, to provide privacy and security, protect against weather, unwanted intrusion or damage and to enhance the aesthetics of a building.

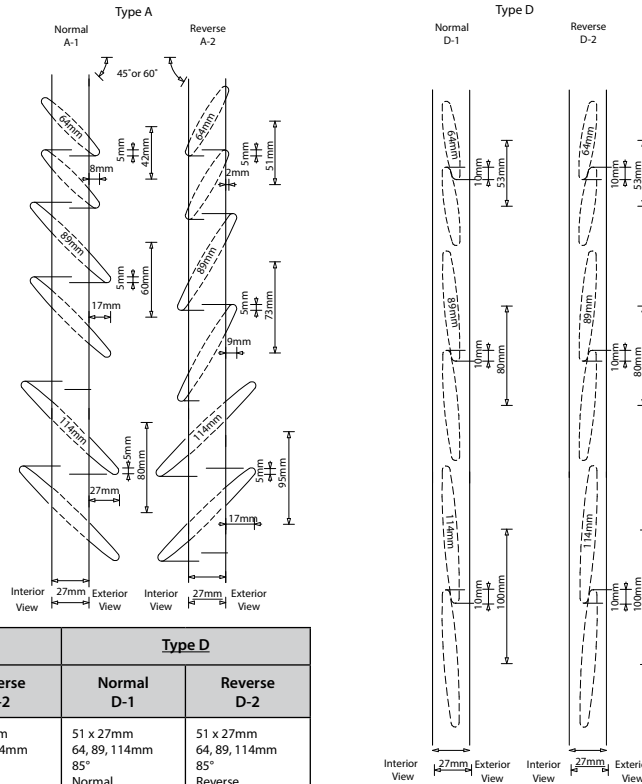

	Type A		Type D	
	Normal A-1	Reverse A-2	Normal D-1	Reverse D-2
Stile (PVC)	51 x 27mm	51 x 27mm	51 x 27mm	51 x 27mm
Louvres (PVC)	64, 89, 114mm	64, 89, 114mm	64, 89, 114mm	64, 89, 114mm
Angles	45° or 60°	45° or 60°	85°	85°
Louvre Facing	Normal	Reverse	Normal	Reverse
Projection (PVC)	8, 17, 27mm	2, 9, 17mm		
Finish (PVC)	Painted	Painted	Painted	Painted

Overview PVC Shutter Specifications:

Louvre Size		Recess	
Type Louvre - Aerofoil	Size 64mm x 11mm 89mm x 12mm 114mm x 12mm	Options Half Open, Fixed, Ventilated, Fixed Non-Ventilated	Size 80mm - 150mm Please Note: Varies, depends on Louvre size.

Finish	
Type Painted	Colours Standard colours: White, Snow, Swiss coffee, Creamy, Butter, Super white, Pearl white, Eggshell, Pearl, Bristle half, Antique white, White on white or Custom Colour

Width & Height Hinged	Stile & Rails
Type Maximum Width Maximum Width Minimum Width Minimum Height Maximum Height	Size 750mm (Single Panel) 500mm (Bi-fold Panel) 300mm (Single Panel) 300mm 2400mm Note: Shutters over 1500mm in height will be constructed with a mid-rail
	Type Stile Top Rail Mid Rail Bottom Rail Tilt Mechanism
	Size 60mm x 30mm 70mm - 150mm x 20mm (varies, depends on height of panel) 82.6mm x 20mm Shutters over 1500mm 1 mid-rail 70mm - 150mm x 20mm (varies, depends on height of panel) Tilt Rod 15.8mm x 12.5mm Clear view concealed
	Options Square D-mould Tilt Rod (centered, left, right) Clear View

Track Systems	
Type Maximum Width Maximum Height	Multi-fold 500mm per Panel (maximum 8 x Panels on each side) 2400mm Note: Shutters over 1500mm in height will be constructed with a mid-rail
	Single Run 900mm per Panel (maximum 6 x Panels on each track) 2400mm Note: Shutters over 1500mm in height will be constructed with a mid-rail

SPECIFICATIONS

PVC Shutters

Hardware Technical - Tracking systems, Hinges

Hardware Overview

Tracking Systems

Window Treatments supplies two tracking systems: Multi-fold for bi-fold shutters, and Single Run for straight sliding shutters. For special applications Window Treatments can supply various track options to suit your requirements.

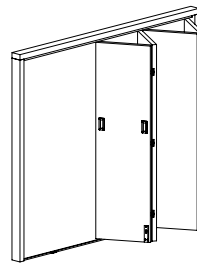

Multi-fold for Bi-fold shutters

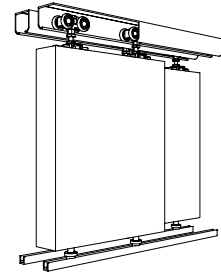

Single Run for straight sliding

Hinges

Depending on the type of shutter installation, Butt Hinge and Steadman Hinge are the standard hinges. For special applications, Window Treatments also supplies various hinge options such as Handle hinges to suit your requirements.

Butt Hinge

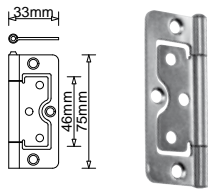

Steadman Hinge

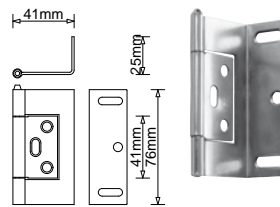

Handle Hinge

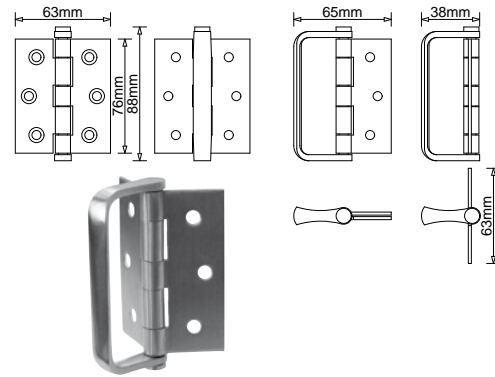

Barrel Bolt

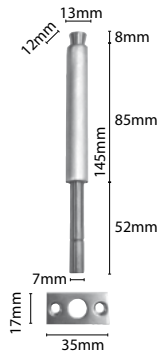

Magnetic Catch

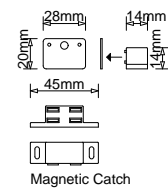

Magnetic Catch

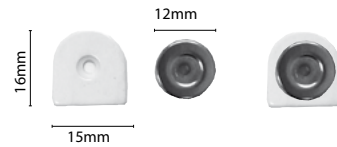

Ball Stop

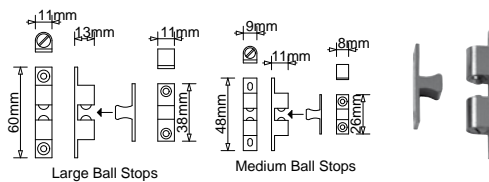

Type	Colours Available	Suitable for
Butt Hinge	Stainless Steel, Silver, Cream, White, Black, Antique Brass, Bright Brass	Square, Rabbit, T Post, L Frame
Steadman Hinge	Stainless Steel, Silver, Cream, White, Black, Antique Brass, Bright Brass	Hang Strip, protruding past window opening
Handle Hinge	Stainless Steel	Bi-fold, assists panel movement
Barrel Bolt	Stainless Steel	Bi-fold, Sliding, Panel
Ball Stops	Brass, Chrome	Securing Fixed Panel
Magnetic Catch	Brown, White, Black	Securing Bi-fold Panel

PVC Shutters

- Hardware Technical - Sliding Single Run

Application

- Widely used in lighter commercial and industrial applications
- To cover any width of opening, any number of panels can be used
- To accommodate different building designs, panels can slide to one or both sides
- Hinged panel for easy access may be incorporated into a sliding panel
- Where panels are fitted externally, a canopy is recommended



Panel Specification

Track System: Single Run (individual Panels)

Max Panel Height: 2400mm

For ease of operation it is recommended that the panel width should not exceed 75% of the panel height.

Panels for interior use can be of flush construction or glazed. Panels for industrial applications should be framed, ledged and braced.

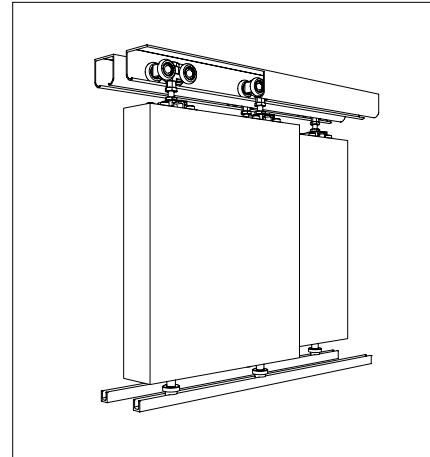

Hardware Specification

Track : 80A
 Material : Aluminium
 Standard lengths : 2000mm, 3000mm, 4000mm, 6000mm
 Aluminium track available in mill or clear anodised finish.

Door Stop : 20DS (Stainless Steel)

Hangers (2 per door) :
 Interior : No. 57EN Hamger
 Hangers supplied with fixing plate and nylon tyred precision bearings. Vertical adjustment is simple and positive. Nylon tyre wheel hangers should not be used on installation involving temperatures exceeding 80°C.

Guide : No. 801S
 Spring loaded guide, nylon body and tip with stainless steel shaft and spring.
 Designed to slide in the No. 92 Threshold

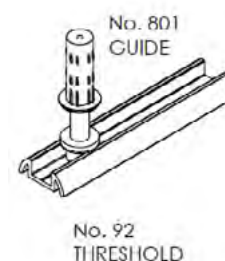
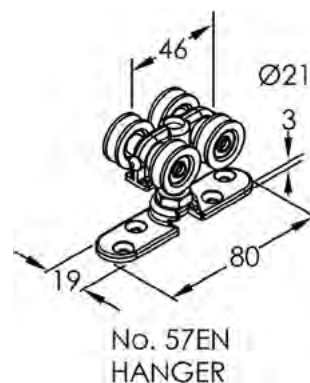
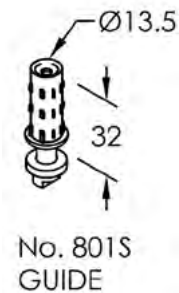
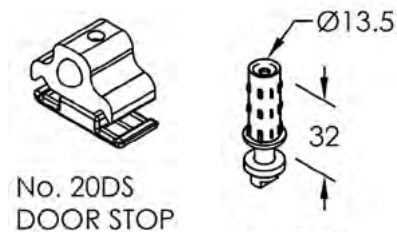

SPECIFICATIONS

PVC Shutters

- Hardware Technical - Multi-fold

Application

- Suitable for residential and light commercial folding shutters with all panels of equal width. Panels can fold to one or both sides of the opening
- Pivot hardware enables a folding exterior shutter to be designed using equal width panels with no cutting down of the panel adjacent to the post.
- To cover any width opening, any number of folding units can be used.



Panel Specification

Track System: Multi-fold (individual leaves)

Max Leaf Height: 2400mm

Max Leaf Width: 500mm

Units of up to six panels can be pivoted to each side of the opening.

A guide system across the floor must be used on units of three panels or more. Floating units consist of four to six panels. Shutters should be constructed to provide secure fitting for the pivot sets, hangers, hinges and guides.

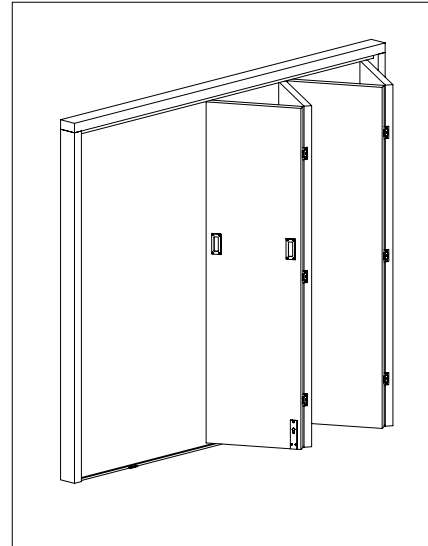

Hardware Specification

Track - punched for soffit fitting: 80A

Material : Aluminium

Standard lengths : 2000mm, 3000mm, 4000mm, 6000mm

Top Pivot Assembly : 21EPNC Steel, Zinc dichromated, Nylon

Bottom Pivot : 21EPNC Steel, Zinc dichromated, Nylon

Door Stop : 20DS (Stainless Steel)

Hangers : No. 57EN Hanger

The hanger is fitted with four nylon tyred ballrace wheels. The adjustment bolt is attached to the top plate and secured in place with a blocking clip which allows easy installation. All steel parts are zinc dichromated.

Guide : No. 801S

Spring loaded guide for use with No.92 Threshold. Guide is nylon and stainless steel.

Threshold : No. 92

Threshold, aluminium, available in 2100mm, 3000mm, 4000mm, 6000mm

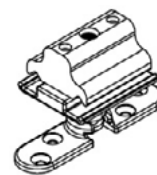

No.21EPNC
Top Pivot

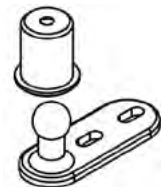

No. 21EPNC
PIVOT



No. 20DS
DOOR STOP

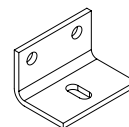

No. ADP1/60 Bracket

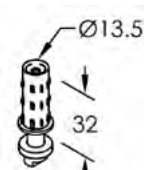

No. 801S
GUIDE



No. 92
THRESHOLD

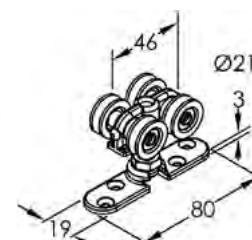

No. 57EN
HANGER

Motorised Shutters

A Shutter 12v Motor Upgrade is available and is particularly useful where shutters are installed in "out of reach" places such as skylights and high gable-end windows.

- Shutter motors can also be installed onto existing shutters and on all types (Basswood, PVC, Aluminium & Cedar).
 - The 12v rechargeable battery motor operates the louvre tilt only.
 - Shutter Motors are white
 - Charging of the battery is either by connecting a charger to the detachable battery and or, connecting a solar panel which is fixed onto or close to the glass. *See figure 2 (next page)*
 - The shutters motors are controlled by a 15-channel remote allowing multiple shutters to be controlled with one remote.
- **Rectangular shaped shutters:**
 - The motor is fitted onto the stile facing the glass, so it is not easily seen from the inside. *See figure 1*
 - The motor is fitted to the shutter stile on the opposite side to the Clear View Tilt Rod.
 - The minimum height of the shutter panel to accommodate a Shutter Motor is 400mm
 - **For Raking (sloping) shutters:**
 - The motor is fitted onto the stile facing the glass so it is not easily seen from the inside. *See figure 1*
 - The motor can only be fitted to the short side of the panel. The clear View Tilt Rod is always fitted to the long side of the panel. *See figure 1*
 - The minimum height of the short side of the shutter panel to accommodate a Shutter Motor is 400mm

Figure 1

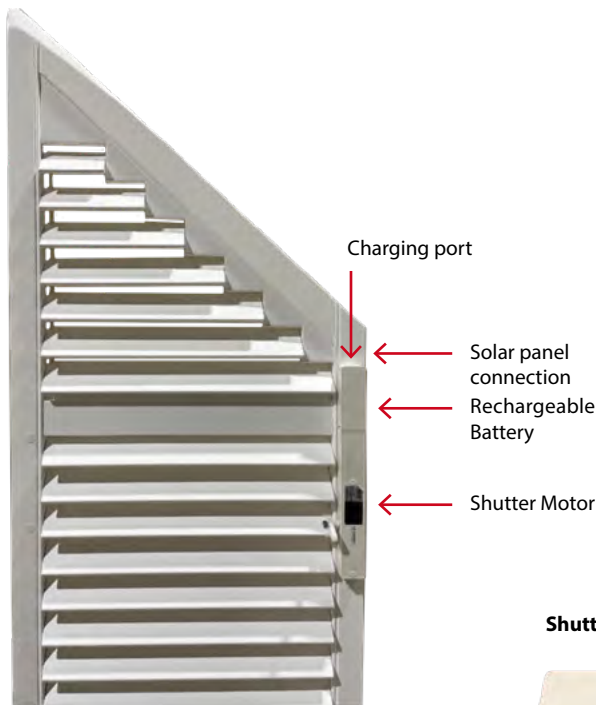

1. The motor and battery are always fitted to the short side of a raking shutter
2. In the example above, the rechargeable battery sits on top of the motor. If the motor is fitted to the opposite side of the shutter, the rechargeable battery sits under the motor

Shutter Motor AM20 Specifications



Voltage	5VDC
Torque	50N
Speed	8mm/s
Radio Frequency	433.92MHz
IP Level	IP32
Rated Power	2W
Operated Temperature	-10oC - +55oC
Dimensions	210 x 35 x 20
Battery Capacity	Lithium 900mAh
Battery Dimensions	90 x 35 x 20

SPECIFICATIONS

Figure 2

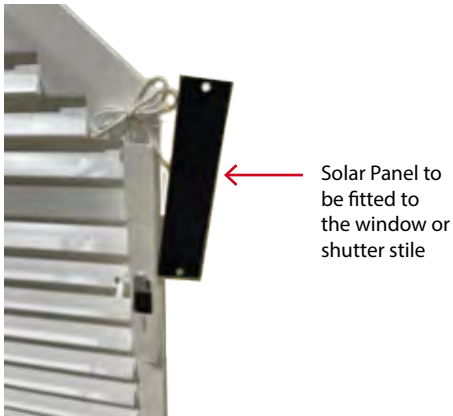

Solar Panel



Dimensions	250 x 60 x 12
Cable Length	1m

Figure 3



Shutter panels with a Clear view Tilt bar can be joined together if requested to allow one motor to operate a shutter which has a midrail

- Shutter panels with a Clear View tilt bar can be joined together if requested to allow one motor to operate a shutter panel which has a mid-rail. *See figure 3*
- Shutter Panels with a Plantation Tilt Bar cannot be joined so a panel with a mid-rail requires two motors.



Awnings



SPECIFICATIONS

Awnings - Overview



Window Treatments offers a wide range of awnings, systems, fabrics and optional extras. Designed to withstand most adverse weather conditions, the mechanisms on our awnings are tough and extremely reliable, requiring little or no maintenance. Using proven European technology and components as the basis for your awning, we will create exactly what you require giving problem-free assembly, installation and operation.

Awning Types

Italia Box

A radial arm, fully cassetted awning suitable for small, medium and large sized windows. The Italia Box awning can span up to 4.5m and is suitable for most domestic and commercial applications.



Palladio

Palladio is a medium to heavy-duty, cassetted folding arm awning for terraces, balconies, shops and restaurants. Palladio is equipped (as standard) with an aluminium cassette to protect the fabric and the inner tube from the elements. Widths of up to 7m and projections of up to 3.6m are available. Solid design, stainless steel chain and powerful springs enable excellent fabric tension.



Operation

Manual or motorised operation available for Italia Box and Palladio awning systems.

Motorisation



Window Treatments' motorised awnings are surprisingly simple and inexpensive. All awning systems can be automated using Somfy's range of motors. These robust motors set the standard for awning automation. Somfy's wide range of weather sensor options include sun, wind and rain control.

An automated awning is capable of extending or retracting automatically when it is needed (Pitch can only be adjusted manually). The benefits of this include protecting your awning from wind damage, making the building appear occupied, and maintaining a comfortable indoor temperature which can reduce cooling costs. A variety of control options are available to suit different automation requirements such as individual control, multiple control, group control, master control or automatic control using weather sensors.

Window Treatments NZ Ltd is an Authorised Somfy Automation Expert. For further information on how a Somfy Automated solution can enhance your design, please contact motorisation@window-treatments.co.nz

Fabrics

A wide variety of colours and fabric options are available for commercial and domestic applications. Our fabrics have excellent U.V. and light fastness protection.

Options Overview

Various options are available to suit your application and/or requirements:

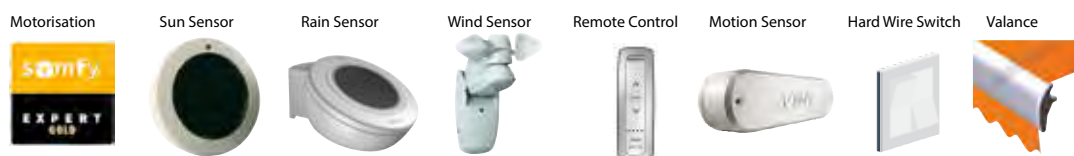

SPECIFICATIONS

Awnings - Italia Box - Specifications

SPECIFICATIONS

Italia Box

Compact radial arm awning

- a popular product for small, medium and large windows



Italia Box is a strong and reliable, fully cassetted radial arm awning suitable for wind speeds up to 35 km/h. Italia Box can be easily controlled from outside and is suitable for private houses, and commercial premises.

The awning has adjustable springs on the radial arms to ensure the best fabric tension for widths up to 4.5m. A stylish aluminium cassette cover and curved front rail enhances the appearance and protects the awning from wind and rain. Italia Box is quick and easy to install on the wall, the top of the window or into a recess. The optimized design and materials of Italia Box ensure a long product life and low maintenance.

Operation

Italia Box can be operated manually by a gear crank drive or by motorization controls. Crank handle lengths are available in 1m, 1.5m or 1.8m, 2.2m to suit the location requirements for manual operation.

Installation

Italia Box awnings can easily be installed directly onto the window architrave, the wall, or under the eaves. We recommend two brackets for awnings up to 2m wide and one additional bracket for every 1.5m in width thereafter.

Radial Arms

Aluminium drop arms with adjustable springs ensure excellent fabric tension.



Components

Manufactured from a selection of anti-corrosive, highly durable materials allows us to offer a comprehensive three year warranty. For installations near coastal areas we recommend washing components and rails with fresh water 3 or 4 times a year.

Installation Dimensions

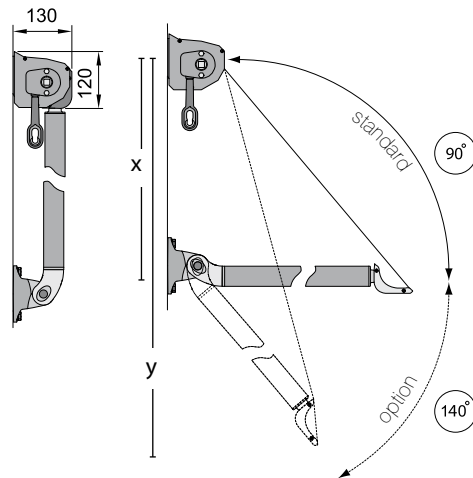

x = projection x 1
y = projection x 2 (approx)

Dimensions

Standard projection (m): 1.0m and 1.4m
Special projections (less than 1.4m) are available on request (minimum projection is 0.6m).
Minimum width: 1.0m per unit
Maximum width: 4.5m per unit

Optional Extras

Crank Handle



Motion Sensor



Wind Sensor



Sun Sensor



Rain Sensor



Motorisation



Valance



Awnings - Italia Box - Specifications



Italia Box Specifications

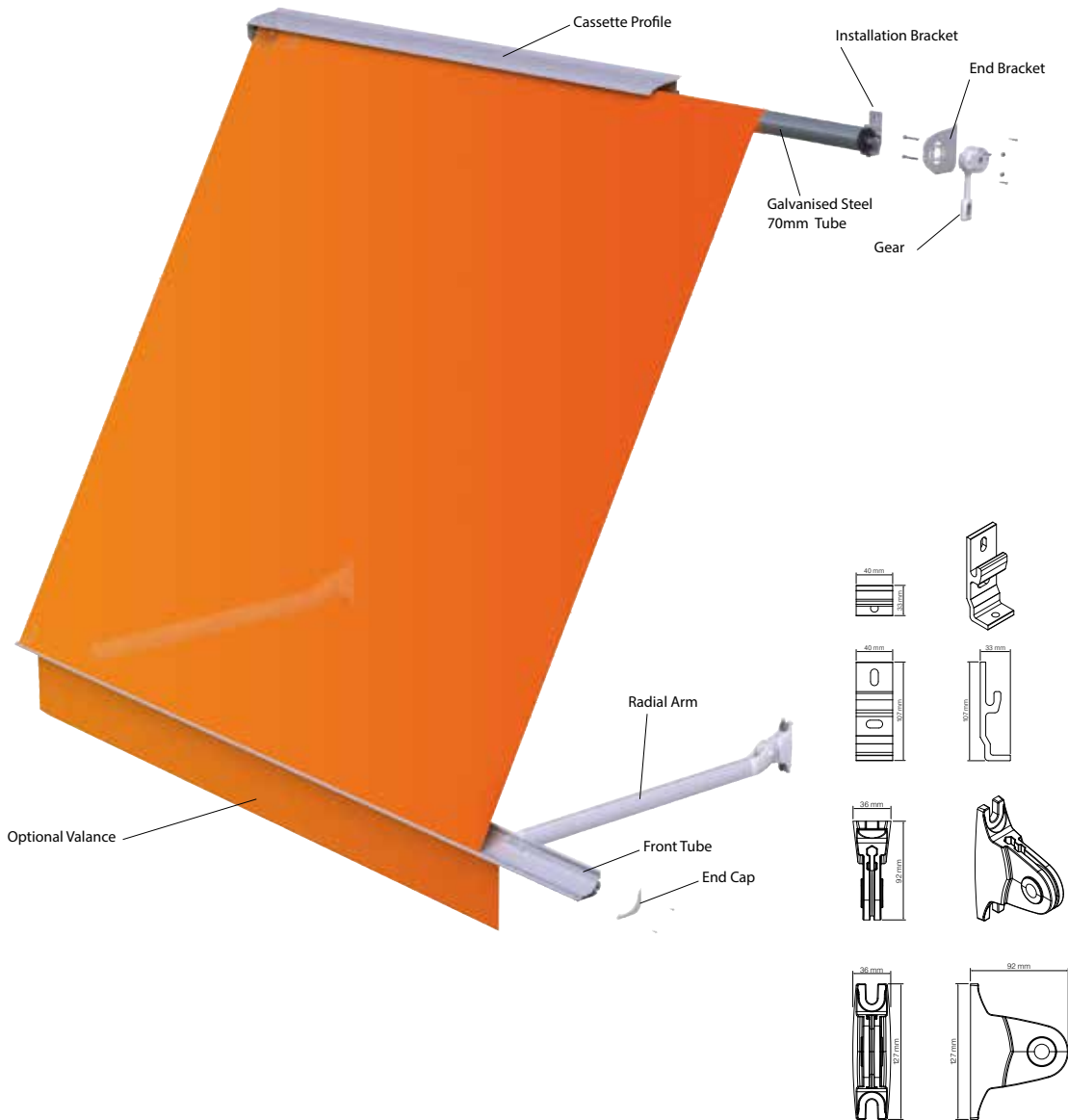

Description

Range of Application

Italia Box is a compact, fully cassetted radial arm awning suitable for most buildings such as villas, town houses, offices, shops, schools and hospitals.

Operation

External operation with manual gear crank drive or motor. The motor can be completed with automatic controls for example sun and wind sensors.

Installation

The awning can easily be installed directly onto the window architrave, the wall, or under the eaves.

Drop Arms

The arm profiles are manufactured with extruded aluminium. Radial arms incorporate adjustable springs for excellent fabric tension. Drop arms can be lowered up to 140° (Standard angle of 90° pictured above).

Components

Cassette and brackets are manufactured of Aluminium. The removable steel crank handle is powder coated. End caps for front tube are manufactured of Aluminium. Fasteners are manufactured of stainless steel.

Tube

Roller tube (70mm) is manufactured of Galvanised Steel.

Standard Colours

The following parts are available in our Standard Perla powder coating: cassette profile, front tube, arms, end caps, crank handle.

Special Colours

On request, special colours are available on a limited selection of parts including front tube, cassette profile and brackets. Radial arms are only available in Perla.

SPECIFICATIONS

Sec. : Awnings
Date : Aug 2015

Palladio

Medium to Heavy-duty Cassetted folding arm awning



Palladio is a medium to heavy-duty cassetted folding arm awning for terraces, balconies, shops and restaurants, designed for sun shading and withstanding wind speeds of up to 35km/h. Palladio is not designed as a rain shelter therefore we recommend retracting the awning when rain is imminent. Solid design, stainless steel chain and powerful springs enable excellent fabric tension. The Pitch (which can only be manually adjusted) allows you to position the angle of the awning for maximum shade comfort whatever the height of the sun. Palladio is equipped (as standard) with an aluminium cassette to protect the fabric and the inner tube from the elements. Widths of up to 7m and projections of up to 3.6m are available. The highest quality materials are used to ensure outstanding performance and reliability at all times. The standard aluminium cassette provides a more attractive appearance and excellent protection of the fabric compared to an "open" folding arm awning.



Operation

There is a choice of manual crank control or motorised control (note: pitch can only be manually adjusted regardless of control choice). Crank handle lengths are available in 1m, 1.5m, 1.8m or 2.2m to suit the location requirements for manual operation. Motorisation allows the awning to be operated using a remote control or automatically controlled by, sun, rain or wind sensors.

Installation

The Palladio awning is designed so it can be easily installed directly on to the wall or under the eaves. The minimum recommended fixing height to the top of the awning (for a 2.1m arm projection awning without overlapping arms) is 2.3m. This increases to 2.5m for a 3.6m arm projection. For overlapping arms fixing height for a 2.1m arm projection is 2.56m and increases up to 3.3m for 3.6m arm projection.

Folding Arms - without overlap

Palladio is a medium to heavy-duty, cassetted folding arm awning for terraces, balconies, shops and restaurants, designed to withstand wind speeds of up to 35km/h. Solid design, stainless steel chain and powerful springs enable excellent fabric tension.



Folding Arms - with overlap

For those situations where a large projection is required but the width of the awning is limited by the installation location, Palladio has the option of "overlapping arms". Overlapping arms enable awnings to be constructed with narrow widths not normally possible with conventional arms. Overlapping arms are available in projections of 2100mm, 2600mm, and 3100mm.



Palladio Specifications

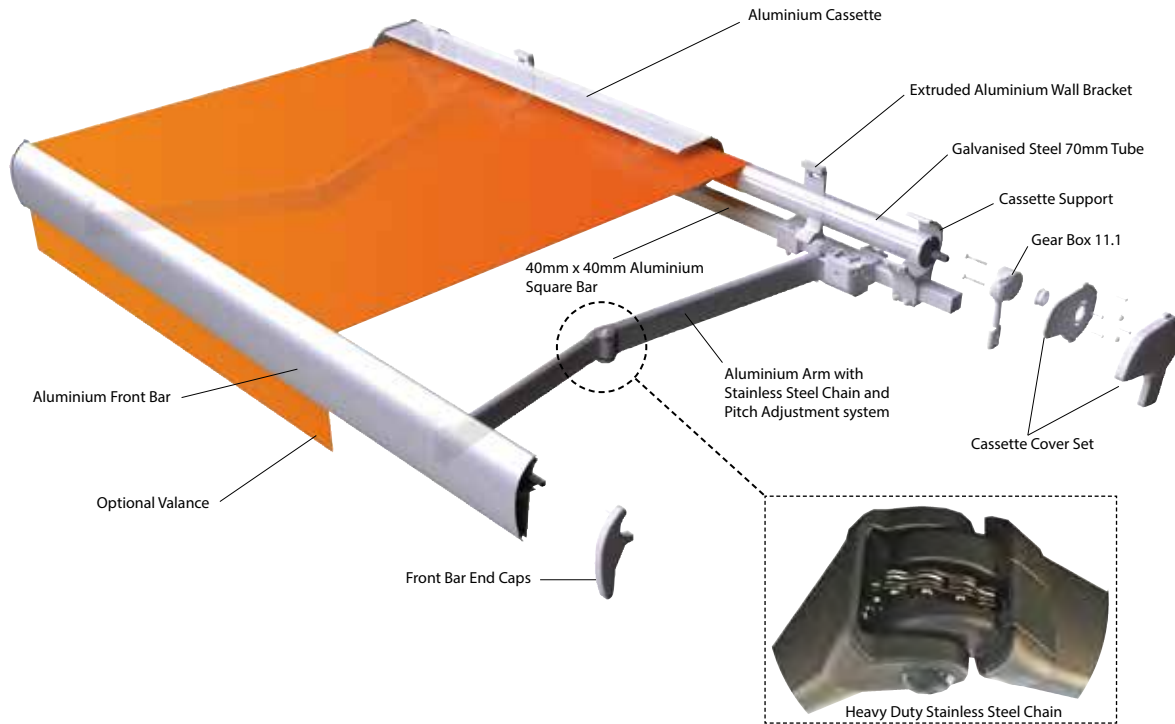

Description

Range of Application

Palladio is a medium to heavy-duty cassetted folding arm awning designed for terraces, bungalows, balconies, kiosks, shops and restaurants.

The projection angle (pitch) is adjustable to any angle between 5° and 50°.

Operation

External operation by a gear crank drive or motorisation controls. The motor can be controlled with a remote control or automatically controlled by sun, wind and rain sensors (note: pitch can only be manually adjusted regardless of control choice).

Installation

The awning can be easily installed directly onto the wall or under the eave. Flexible roof brackets or Rafter Mount brackets are available.

Folding Arms

The arm components are manufactured of pressure die casted aluminium and the arm profiles of extruded aluminium. Heavy-duty springs provide an excellent tension of the fabric and improved awning stability.

Components

The installation brackets, end bracket and cassette supports are manufactured of extruded aluminium. Gears are manufactured of pressure die cast zinc. The removable steel crank handle is powder coated.

Marine grade (316) stainless steel bolts & screws are used in assembly of the awning. Wall fittings are galvanised. Manufactured from a selection of anti-corrosive, highly durable materials allows us to offer a comprehensive three year warranty. For installations near coastal areas

we recommend washing components and rails with fresh water 3 or 4 times a year.

Profiles

The front tube and hood profile are manufactured of extruded aluminium.

Roller tube 70mm is manufactured from galvanised steel. Square tube 40mm x 40mm is manufactured from extruded aluminium with internal strengthening ribs.

Standard Colours

All external parts including, square bar, aluminium rails, arms and crank handle are colour coordinated in your choice of Perla, Bronze or Gun Metal.

Special Colours

On request, special colours are available on a limited selection of parts. These are: square bar and arm supports, aluminium rail, box profile, box supports and front profile, wall and ceiling brackets and overlapping arm supports. All other components (including arms) are only available in Perla, Bronze or Gun Metal.

Dimensions

Top Fix - Depth 240mm, height 226mm.

Face Fix - Depth 225mm, height 205mm with hood.

Rafter Fix - Depth 350mm, height 406mm.

Projection (m): 2.1, 2.6, 3.1 and 3.6 (refer chart overleaf).

Min Width: Non-overlapping arms - 2.6m (2.1m projection)

Overlapping arms - 1.7m (2.1m projection)

Refer to chart overleaf for minimum widths for other projections

Max width: 7.0m.

Installation Dimensions for Crank Handle & Motorised

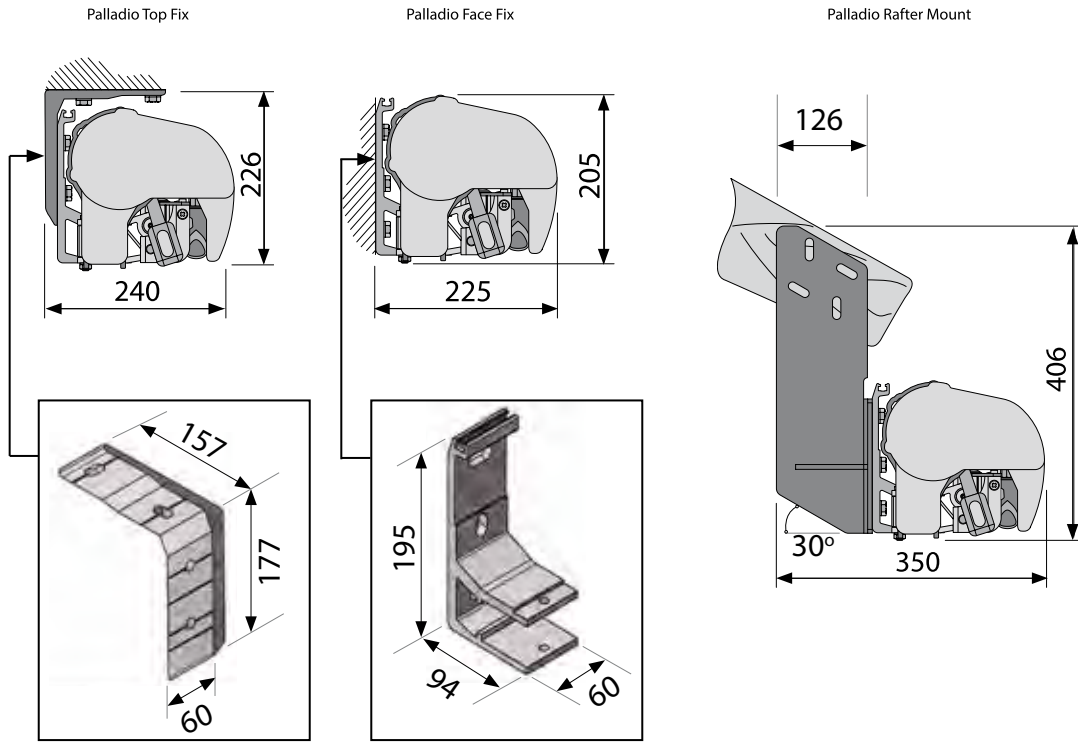

Palladio - Standard Arms (not overlapping)	
Minimum widths for each projection of non overlapping arms and number of installation brackets for each width ()	
Projection (mm)	Minimum width 2 arm awning
2100	2600mm (4 brackets)
2600	3100mm (4 brackets)
3100	3600mm (5 brackets)
3600	4100mm (5 brackets)

Palladio - Overlapping arms	
Minimum widths for each projection of overlapping arms and number of installation brackets for each width ()	
Projection (mm)	Minimum width 2 arm awning
2100	1700mm (3 brackets)
2600	2200mm (4 brackets)
3100	2700mm (4 brackets)
3600	Not available



Optional Extras

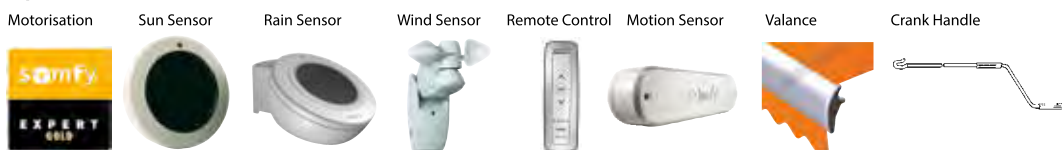

Telescopic front bar supports

In exposed areas, "telescopic front bar supports" can be connected to the front bar (2.1m, 2.6m, 3.1m projections only) to counter the sail effect of the awning. The supports must be disconnected prior to retracting the awning and to prevent damage we advise against supports when wind sensors are used.

Awnings - Motorisation Italia Box



Motorisation



Window Treatments' motorised awnings are surprisingly simple and inexpensive. All awning systems can be automated using Somfy's range of motors. These robust motors set the standard for awning automation. Somfy's wide range of weather sensor options include sun, wind and rain control.

An automated awning is capable of extending or retracting automatically when it is needed. The benefits of this include protecting your awning from wind damage, making the building appear occupied, and maintaining a comfortable indoor temperature which can reduce cooling costs. A variety of control options are available to suit different automation requirements such as individual control, multiple control, group control, master control or automatic control using weather sensors.

Window Treatments NZ Ltd is an Authorised Somfy Automation Expert. For further information on how a Somfy Automated solution can enhance your design, please contact motorisation@window-treatments.co.nz

Italia Box Motorisation (optional)

Italia Box uses six different types of motors for automation depending on the size of the awning installation. Refer to Motor selection chart.

Motor Selection		Width <2.5m	Width >2.5m	4 Arms
Italia Box	RTS	Altus 10/17	Altus 25/17	Altus 40/17
	WT	Jet 10/17	Gemini 25/17	Mariner 40/17

KEY:

WT = Mechanical switch hardwired to the motor.

RTS = Remote control (handheld or wallmounted)

Maximum Width:4.5m

Maximum Projection: 1.4m

Performances	Altus 10/17	Jet 10/17	Altus 25/17	Gemini 25/17	Altus 40/17	Mariner 40/17
Torque	10 Nm	10 Nm	25 Nm	25 Nm	40 Nm	40 Nm
Nominal Voltage	230v	230v	230v	230v	230v	230v
Rated Current	0.5 A	0.5 A	0.8 A	0.8 A	1.2 A	1.2 A
Rated Power	120W	120W	170W	170W	270W	270W
Speed	17 RPM	17 RPM	17 RPM	17 RPM	17 RPM	17 RPM
Thermal Protection	4 Min	4 Min	4 Min	4 Min	4 Min	4 Min
Radio Frequency	433.42	433.42	433.42	433.42	433.42	433.42
Sound Level (DB)	47	47	56	56	57	57
Cable Length	3000mm	2500mm	3000mm	2500mm	3000mm	2500mm
IP Rating	IP 44	IP 44	IP 44	IP 44	IP 44	IP 44
Insulation Class	I	I	I	I	I	I

Somfy Sensors

Weather Sensors can be used for automatic control. These include rain, wind and sun sensors. Rain and wind sensors will retract your awning when it is raining, or if wind speeds exceed 35 km/h. The sun sensor works on light level and can be programmed to a specific light level.

Sunis Wirefree
RTS Sun Sensor



Wind Sensor



Ondeis Rain Sensor



Remote Control



Hard Wire Switch



Motion Sensor



SPECIFICATIONS

Sec. : Awnings
Date: Jun 2021

Awnings - Motorisation Palladio

Motorisation

Window Treatments' motorised awnings are surprisingly simple and inexpensive. All awning systems can be automated using Somfy's range of motors. These robust motors set the standard for awning automation.



Somfy's wide range of weather sensor options include sun, wind and rain control.

An automated awning is capable of extending or retracting automatically when it is needed (note: pitch can only be manually adjusted). The benefits of this include protecting your awning from wind damage, making the building appear occupied, and maintaining a comfortable indoor temperature which can reduce cooling costs. A variety of control options are available to suit different automation requirements such as individual control, multiple control, group control, master control, automatic control using weather sensors and manual override in the event of power failure (Only when model CSI 40/12 motor is used). Awnings are installed by Window Treatments installers with Somfy 230v Tubular motors which are housed inside the awning tube. The motors have a 3m power flex which is to be connected to the power supply by a registered Electrician. Window Treatments can recommend an electrician to complete this work if necessary.

Window Treatments NZ Ltd is an Authorised Somfy Automation Expert. For further information on how a Somfy Automated solution can enhance your design, please contact motorisation@window-treatments.co.nz

Palladio Motorisation (optional)

Palladio uses six different types of motors for automation depending on the size of the awning installation. Refer to Motor selection chart.

Motor Selection		Projection <2.6m	Proj >2.6m	KEY: WT = Mechanical switch hardwired to the motor. RTS = Remote control (handheld or wallmounted) Maximum Width:7m Maximum Projection: 3.6m
Palladio	RTS	Altus 25/17	Altus 40/17	
	WT	Gemini 25/17	Mariner 40/17	

Performances	Altus 25/17	Gemini 25/17	Altus 40/17	Mariner 40/17	Mariner CSI 40/12
Torque	25 Nm	25 Nm	40 Nm	40 Nm	40 Nm
Nominal Voltage	230v	230v	230v	230v	230v
Rated Current	0.8 A	0.8 A	1.2 A	1.2 A	1.1A
Rated Power	170W	170W	270W	270W	240W
Speed	17 RPM	17 RPM	17 RPM	17 RPM	12 RPM
Thermal Protection	4 Min	4 Min	4 Min	4 Min	4 Min
Radio Frequency	433.42	433.42	433.42	433.42	433.42
Sound Level (DB)	56	56	57	57	55
Cable Length	3000mm	2500mm	3000mm	2500mm	2500mm
IP Rating	IP 44	IP 44	IP 44	IP 44	IP 44
Insulation Class	I	I	I	I	I
Manual Override	No	No	No	No	Yes - RTS Motor, RH Control only

Somfy Sensors

Weather Sensors can be used for automatic control. These include rain, wind and sun sensors. Rain and wind sensors will retract your awning when it is raining, or if wind speeds exceed 35 km/h. The sun sensor works on light level and can be programmed to a specific light level.





Terrazza Patio Awning



SPECIFICATIONS

Terrazza Patio Awning

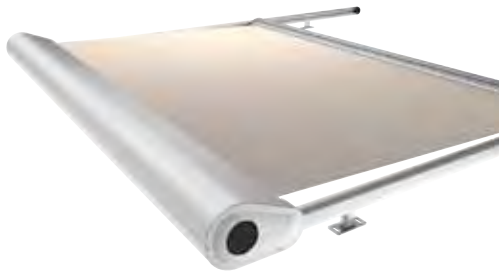

Terrazza Awnings are ideal for providing external sun and wind control and mounted “on top” of a pergola, glass or open roof. In special cases Terrazza can be installed under a pergola or glass roof using additional custom made brackets however the system is primarily designed for “on top” installations. The Terrazza awning has been developed using European technology and components can be installed at any angle/pitch (0° - 180°) providing the cassette and front bar are positioned horizontally level. As Terrazza is designed for sun and wind control only, we recommend retracting the awning when rain is imminent.

All parts are designed for the outdoors with aluminium sliding rails, cassette box, front rails and hard wearing PVC components. Manufactured in New Zealand exclusively by Window Treatments NZ Ltd and covered by a three year warranty.

Motorised Operation Overview



Terrazza awnings are automated using Somfy's range of motors. These robust motors set the standard for awning automation. Somfy's wide range of weather sensor options include sun, wind and rain control.

Motorisation of the Terrazza awning (with sensor options) allows you to extend or retract the awning automatically when it is needed. The benefits of this include protecting your Terrazza awning from wind damage, making the building appear occupied, and maintaining a comfortable indoor temperature which can reduce cooling costs. A variety of control options are available to suit different automation requirements such as individual control, multiple control, group control, master control or automatic control using weather sensors.

Window Treatments NZ Ltd is an Authorised Somfy Automation Expert. For further information on how a Somfy Automated solution can enhance your design, please contact motorisation@window-treatments.co.nz

Hardware Colours

Standard Colour

Most external parts including, cassette, aluminium rails and bottom rail are available in U6 Metal, New White, T6 Ivory, Z2 Matte Black. End caps 1a. and 2a. (see over) are only available in black.



Robust Aluminium fixing brackets colour coordinated with aluminium guide rails, cassette box & front bar

Special Colours

Special colours are available (by request) on most parts including cassette, aluminium rails, and brackets. End caps 1a. and 2a. and moving wheel assembly (see over) are only available in black.

Fabrics

A wide variety of colours and fabric options are available for commercial and domestic applications. Our fabrics have excellent U.V. and light fastness protection. For Solar Screen, Window Treatments recommend Techno X. Techno X is a durable and tough synthetic fabric made of PVC coated polyester. Designed to reduce heat transfer, this fabric also reduces the glare and harmful rays from the sun. While blocking the sun's rays, Solar Screen can help reduce energy costs and provide protection to your furnishings. Flame resistant and fade resistant. Excellent for daytime privacy without blocking the view, this versatile fabric will endure years of outdoor use. Techno X blocks 87% - 93% of the sun's rays.

Maximum Size:

4.0m wide, projection of up to 4.0m (maximum coverage must not exceed 12m²).

Note: A degree of sagging of fabric will occur on larger Terrazza awnings. This sagging can be partly controlled with adjustment to the interior spring tensioning system but will not eliminate sagging completely.

SPECIFICATIONS

Sec. : Terrazza
Date : Jul 2019

Terrazza Patio Awning

Dimensions

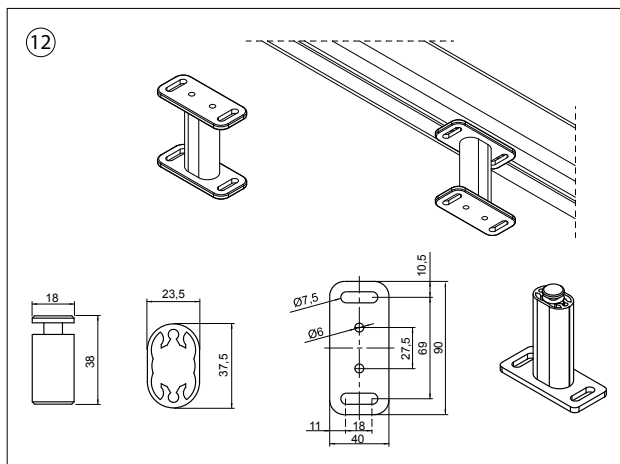
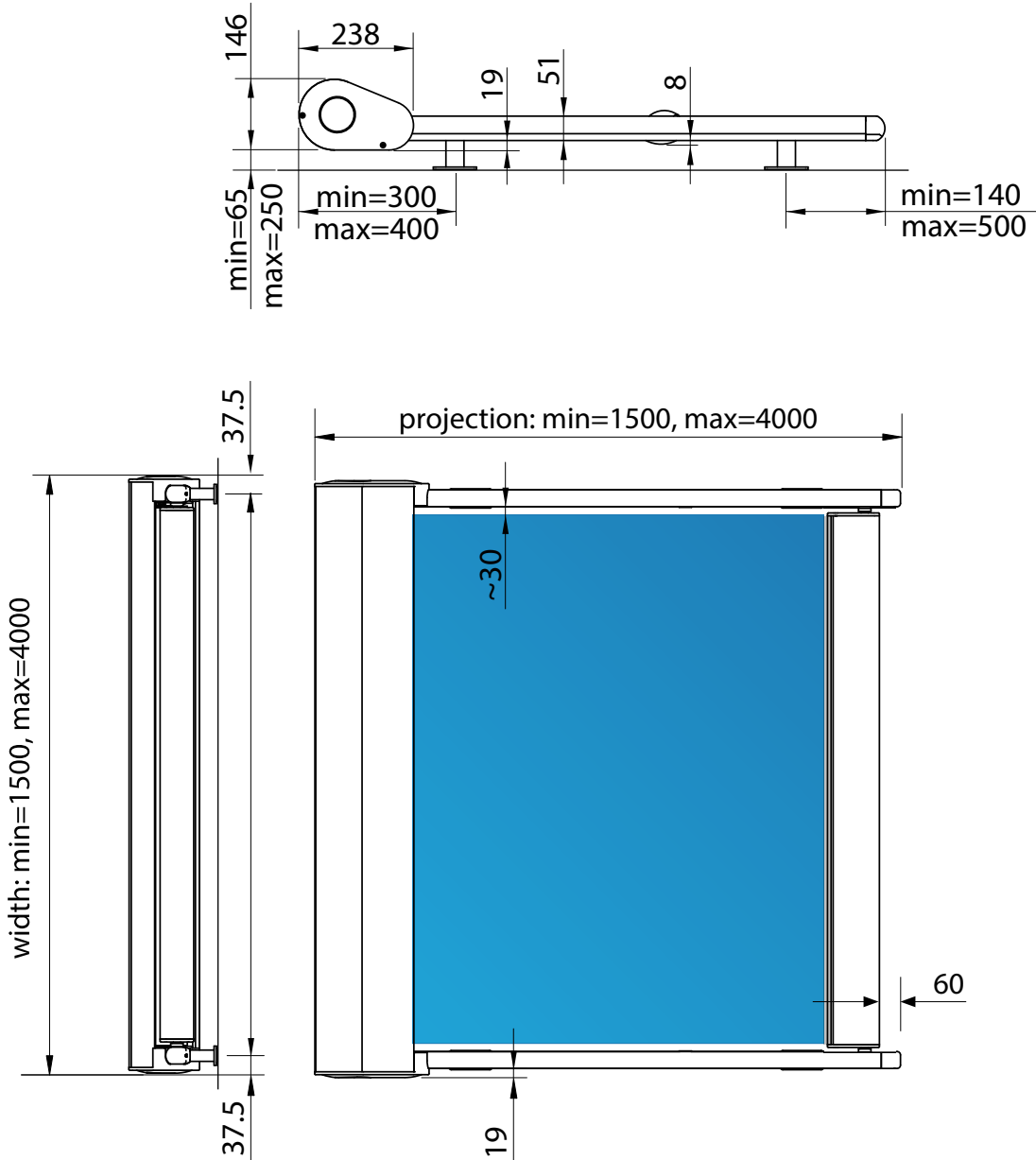

Note: Combined Width and Projection dimensions must not exceed maximum coverage of 12m²

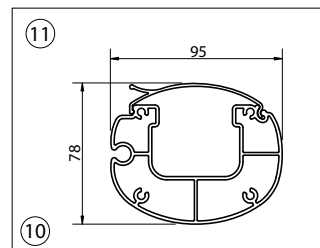

Terrazza Patio Awning



SPECIFICATIONS

Terrazza



Terrazza Components



Motorisation



Sun Sensor



Rain Sensor



Wind Sensor



Remote Control



Motion Sensor



Hard Wire Switch



Sec. :Terrazza
Date: Aug 2015

Awnings - Motorisation Terrazza

SPECIFICATIONS

Motorisation



Terrazza awnings are automated using Somfy's range of motors. These robust motors set the standard for awning automation. Somfy's wide range of weather sensor options include sun, wind and rain control.

Motorisation of the Terrazza awning (with sensor options) allows you to extend or retract the awning automatically when it is needed. The benefits of this include protecting your Terrazza awning from wind damage, making the building appear occupied, and maintaining a comfortable indoor temperature which can reduce cooling costs. A variety of control options are available to suit different automation requirements such as individual control, multiple control, group control, master control or automatic control using weather sensors.

Window Treatments NZ Ltd is an Authorised Somfy Automation Expert. For further information on how a Somfy Automated solution can enhance your design, please contact motorisation@window-treatments.co.nz

Terrazza Motorisation

Terrazza uses four different types of motors for automation depending on the size of the installation. Refer to Motor selection chart.

Motor Selection		<6m ²	>6m ²
Terrazza	RTS	Altus 25/17	Altus 40/17
	WT	Gemini 25/17	Mariner 40/17

KEY:
 WT = Mechanical switch hardwired to the motor.
 RTS = Remote control (handheld or wallmounted)
 Maximum Width:4.0m
 Maximum Projection: 4.0m
 Note: Maximum coverage must not exceed 12m²

Performances	Altus 25/17	Gemini 25/17	Altus 40/17	Mariner 40/17
Torque	25 Nm	25 Nm	40 Nm	40 Nm
Nominal Voltage	230v	230v	230v	230v
Rated Current	0.8 A	0.8 A	1.2 A	1.2 A
Rated Power	170W	170W	270W	270W
Speed	17 RPM	17 RPM	17 RPM	17 RPM
Thermal Protection	4 Min	4 Min	4 Min	4 Min
Radio Frequency	433.42	433.42	433.42	433.42
Sound Level (DB)	56	56	57	57
Cable Length	3000mm	2500mm	3000mm	2500mm
IP Rating	IP 44	IP 44	IP 44	IP 44
Insulation Class	I	I	I	I

Somfy Sensors

Weather Sensors can be used for automatic control. These include rain, wind and sun sensors. Rain and wind sensors will retract your awning when it is raining, or if wind speeds exceed 35 km/h. The sun sensor works on light level and can be programmed to a specific light level.





Louvre Roof



SPECIFICATIONS

Sec. ; Louvre Roof
Date: June 2023



Louvre Roof – Overview

The Louvre Roof is a functional and aesthetic construction set with fixed roof made of rotating blades, which protect against the sun and rain.

USAGE:

- Sun protection and surface shading. It is also rainproof but in adverse weather conditions may not be watertight.

PRODUCT CHARACTERISTICS:

- Extruded aluminium construction with stainless steel elements
- Water drainage system integrated within the construction
- Outflow of water through the posts and exits at the decking or downpipes
The connection of the down pipes to the storm water system completed by others)
- Option for Rain or Wind sensors to operate the louvres automatically.
- Regulates the access of the sunlight according to user needs
- Protects against weather conditions: rain and wind
- Protects against snowfall up to 50 kg/m² (even load)
- The rotation of roof blades may be operated by switch or remotely controlled
- Easy access to the motor

TECHNICAL SPECIFICATION:

- Maximum width of the module 4.1 m
- Maximum projection 7m (no middle post is required for a 7m projection)
- Maximum height between the floor and the underside of the projection beam is 2.8m
- Maximum height from the floor to the top of the beams is 3.01m.
- Free-standing or wall-mounted construction, single- or multi-module
- Manufactured with extruded aluminium profiles and stainless-steel elements, equipped with water drainage system
- Slope angle 0 degrees
- Intervals of roof blades 200 mm
- Blade rotation range: 0-90°
- Recommend opening the Louvres when wind exceeds 65km/hr
- Maximum drainage capacity drains at up to 0.04 l/s/m² at maximum time of 5.3 minutes
- Electric drive: linear motor ELERO Picolo XL (230V AC)
- LED Strip lighting (24V) optional. LED strips are installed just above the louvre gutter on both projection beams
- Standard Colours: Gun Metal, Perla
 - Note: It is possible to have a mix of colours on a Louvre Roof. Example: posts, cross beams, projection beams and gutters in Perla and the louvres in Gun Metal. There is no surcharge with a mix of standard colours
- External durable powder coating system with 60-100 micrometers thickness of coating (Standard PN-EN ISO 2360)
- Special (non-standard) colours are available with a surcharge of 20% with an extra 12 working days lead time

PLANNING/CONSENTS

- Maximum size possible louvre roof without requiring a building consent:
 - When the Louvre Roof is freestanding (not attached a building) is 30m² providing the louvre roof is at ground level
 - When attached to a building is 20m² providing the louvre roof is at ground level
- Louvre Roofs irrespective of size installed on floor levels 1 and above, require a building consent
- Planning permission (PIM) may be required regardless of the louvre roof size
- The customer is responsible to apply and obtain a building consent and/or PIM if required
- Window Treatments NZ Ltd do not apply for building consents when required
- Irrespective of whether a building consent is required, all installations and fixings must meet NZ building code standards.

Installation Types

Single **free-standing** version

NOTE: foot outline may protrude beyond the posts (depending on the type)

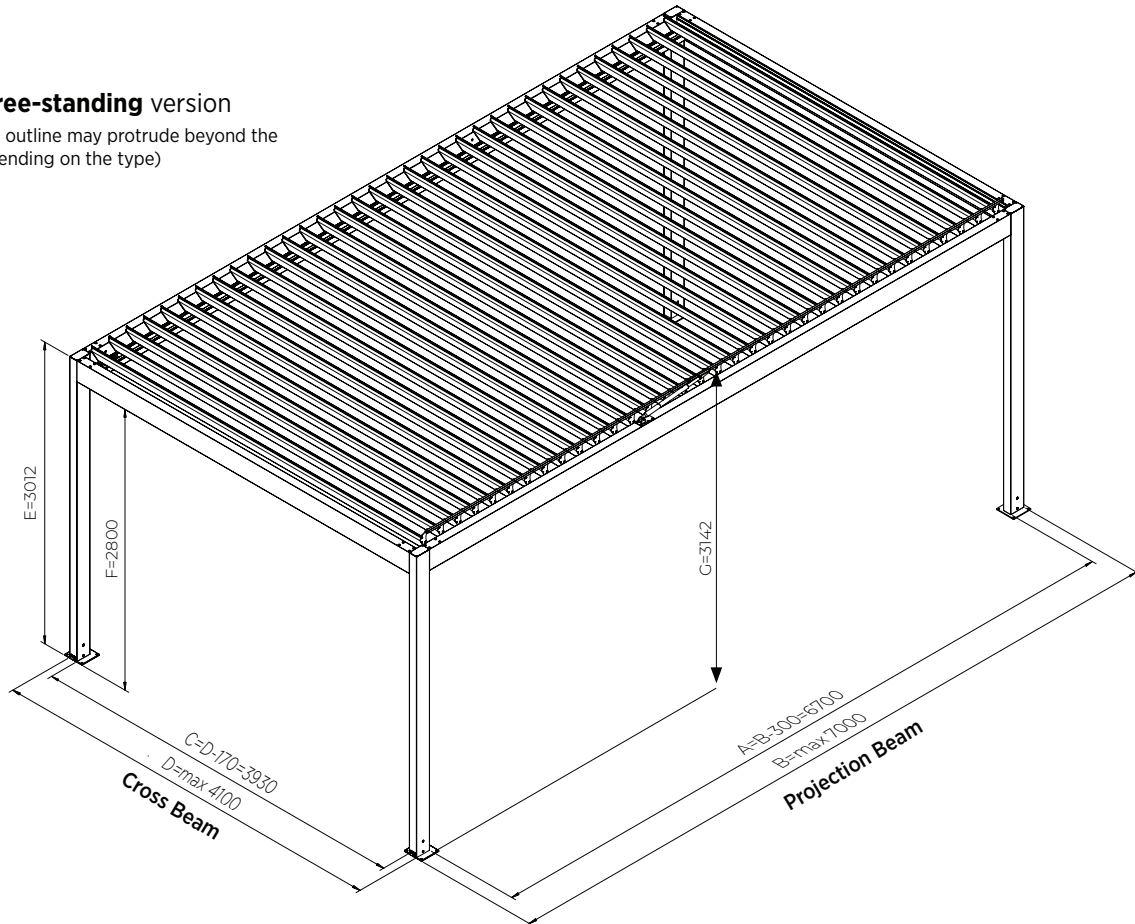

Single **wall-mounted (transverse)** version

NOTE: foot outline may protrude beyond the posts (depending on the type)

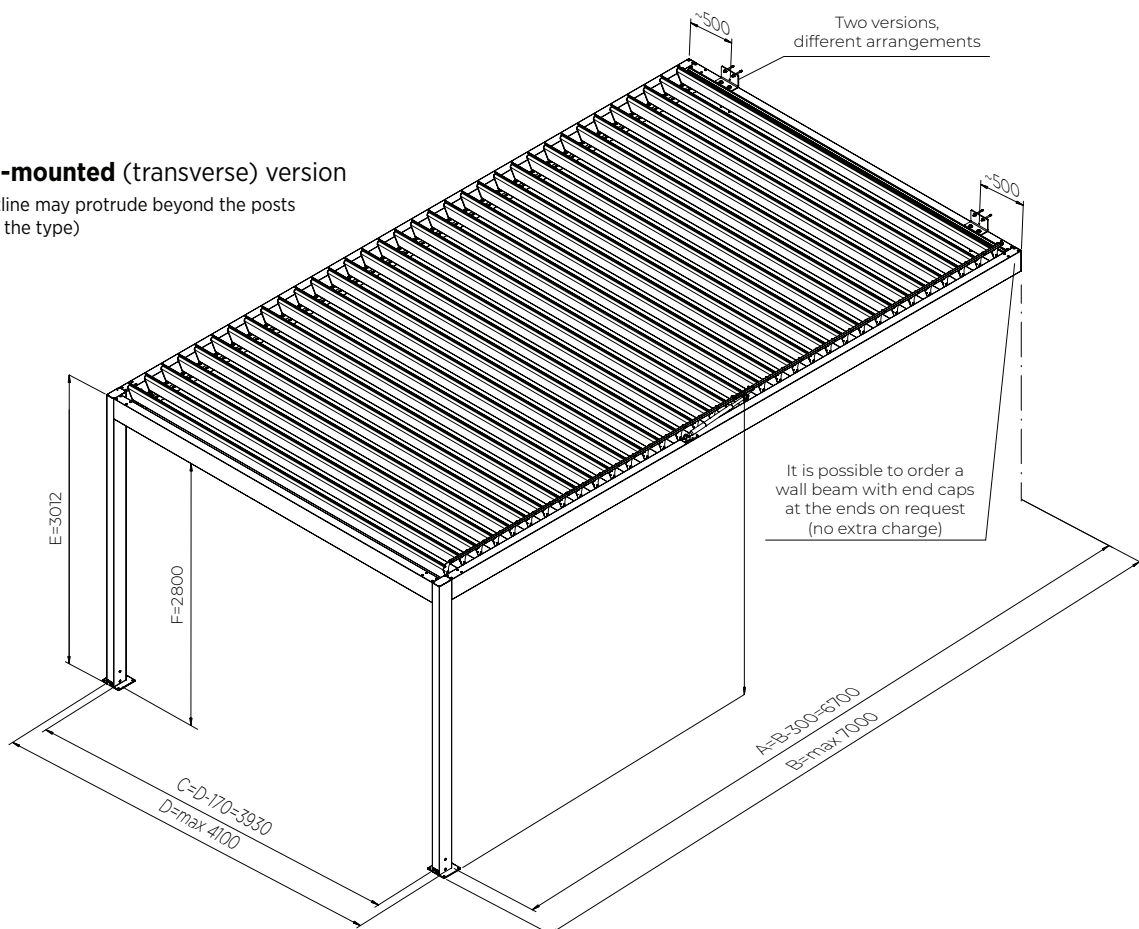

Installation Types

Modular free-standing version

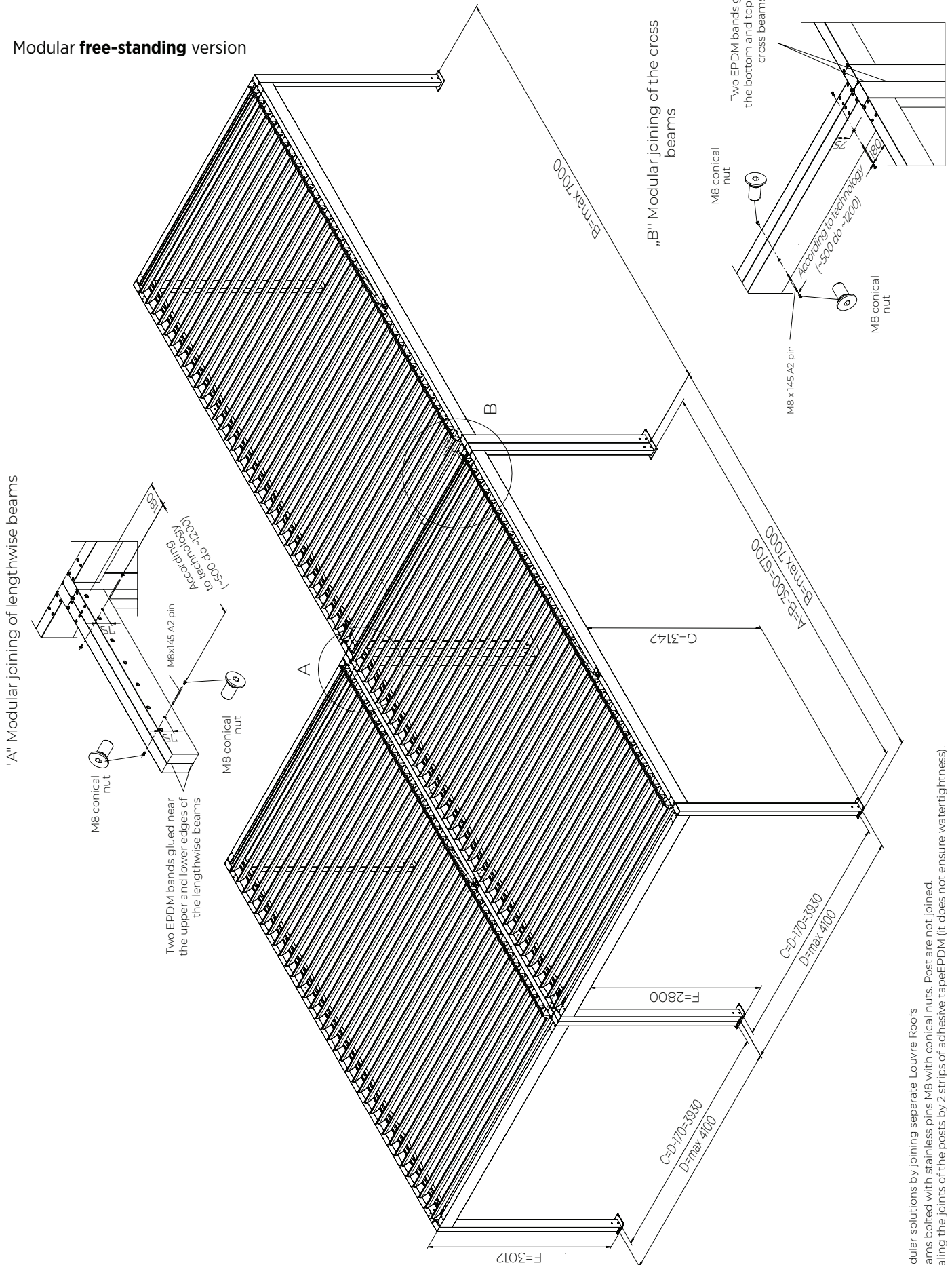

Modular solutions by joining separate Louvre Roofs
 Beams bolted with stainless pins M8 with conical nuts. Post are not joined
 Sealing the joints of the posts by 2 strips of adhesive tape EPDM (it does not ensure watertightness).

Installation Types

Single wall mounted (projection) version

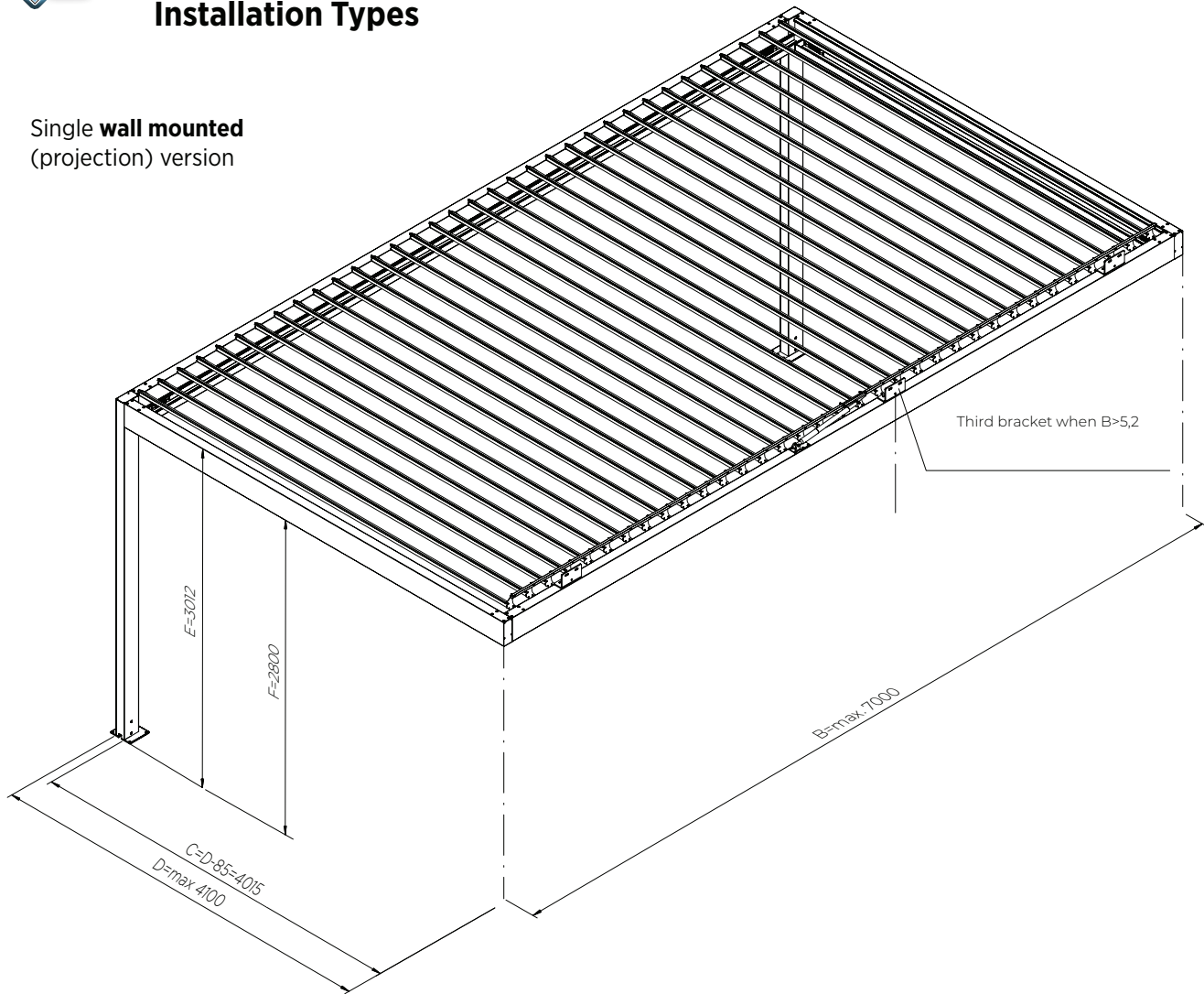

Roof version (without posts)

NOTE: Projection is a multiple of 20 cm. Louvre Roof has 2 gutters on projection beams or 4 perimeter gutters. Water drainage to be made on your own. Anchoring by wall brackets on the projection beams or alternatively on the cross beams. For projection of less than 2 m there is no possibility to drill holes for wall brackets in the projection beam on the drive side. For every module 4 pieces wall brackets are added. By default the brackets are located on projection beams.

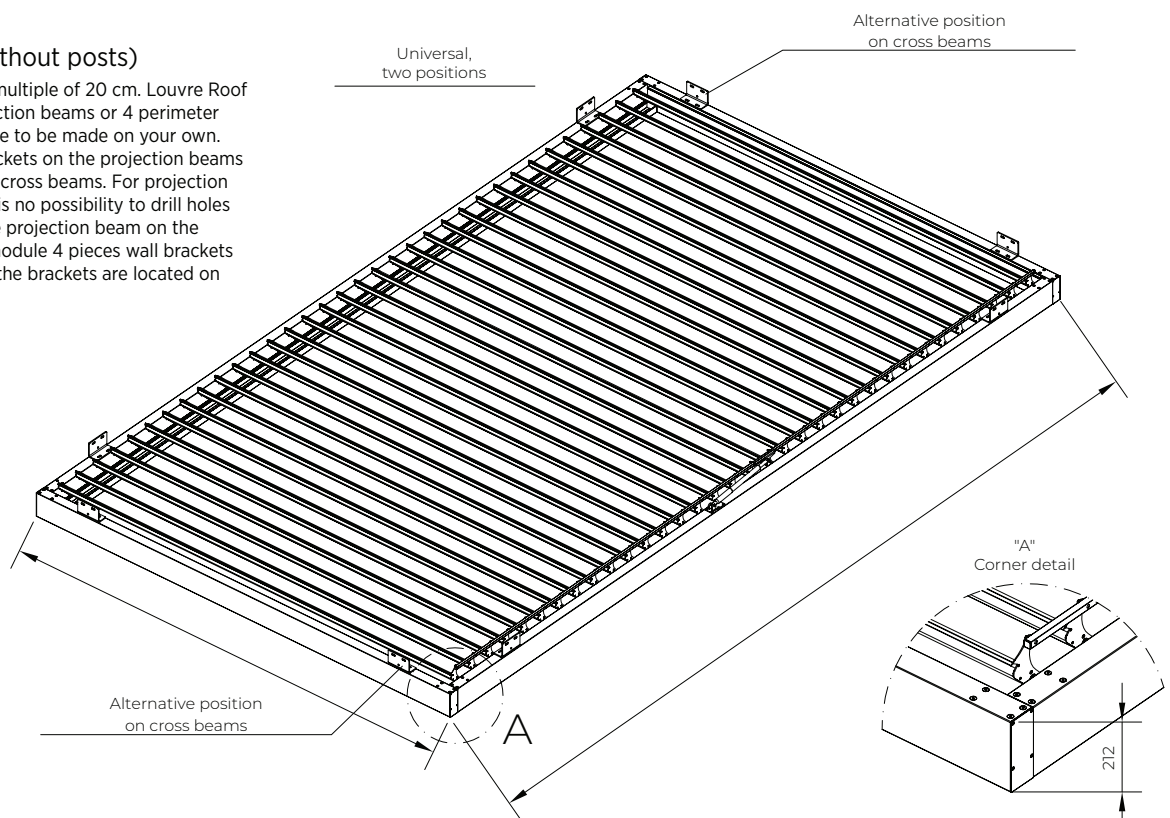

Views and sections

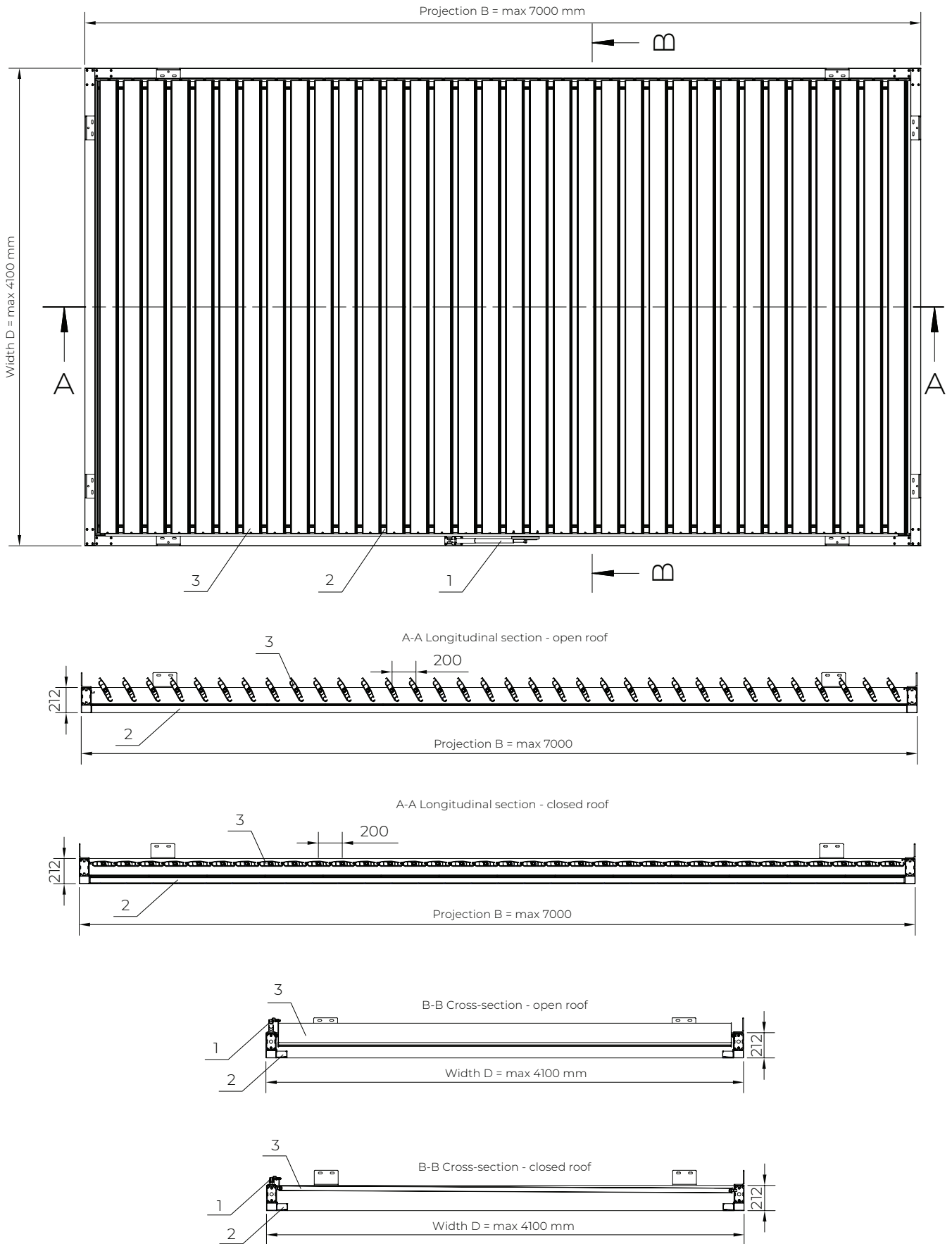

- 1. Motor
- 2. Lengthwise gutter
- 3. Blade

Modular connection

NOTE: Each module should be mounted in 4 corners. Modular connection does not allow to extend the beam spans.

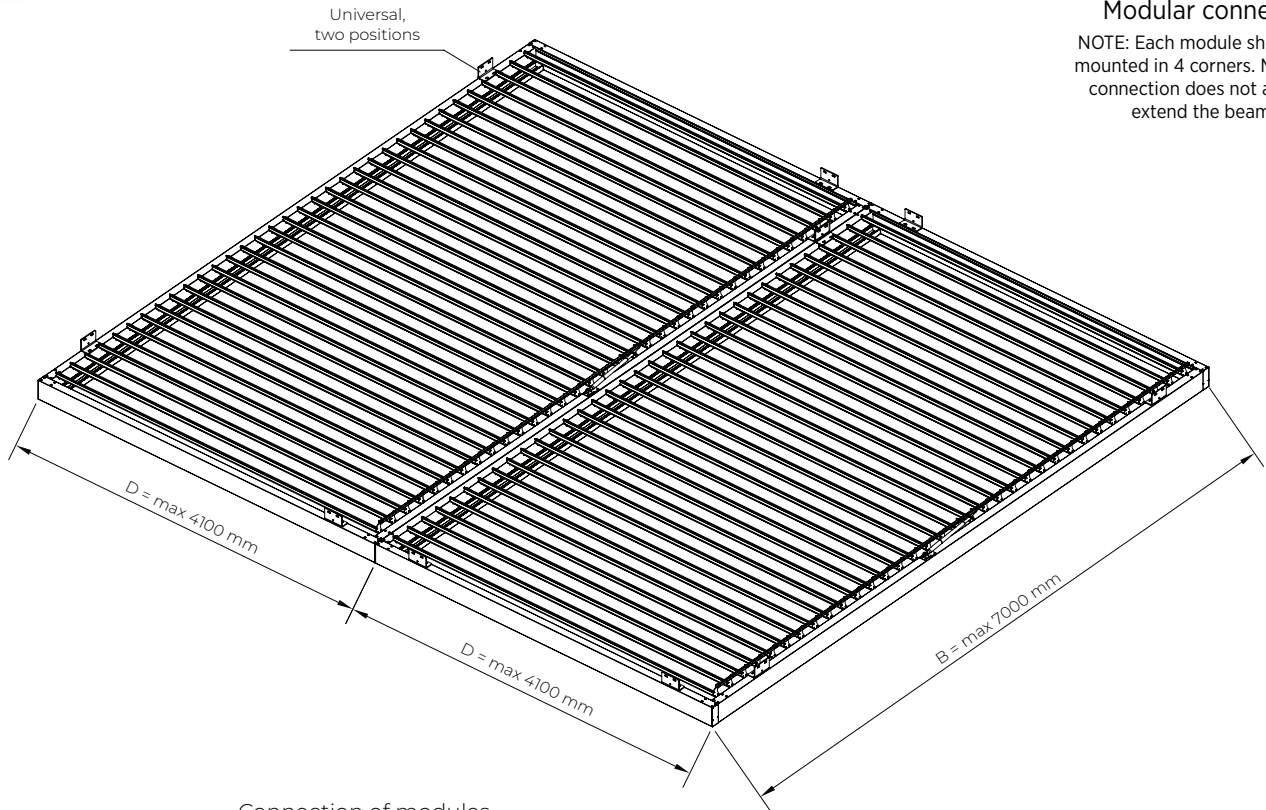

Connection of modules SB400R

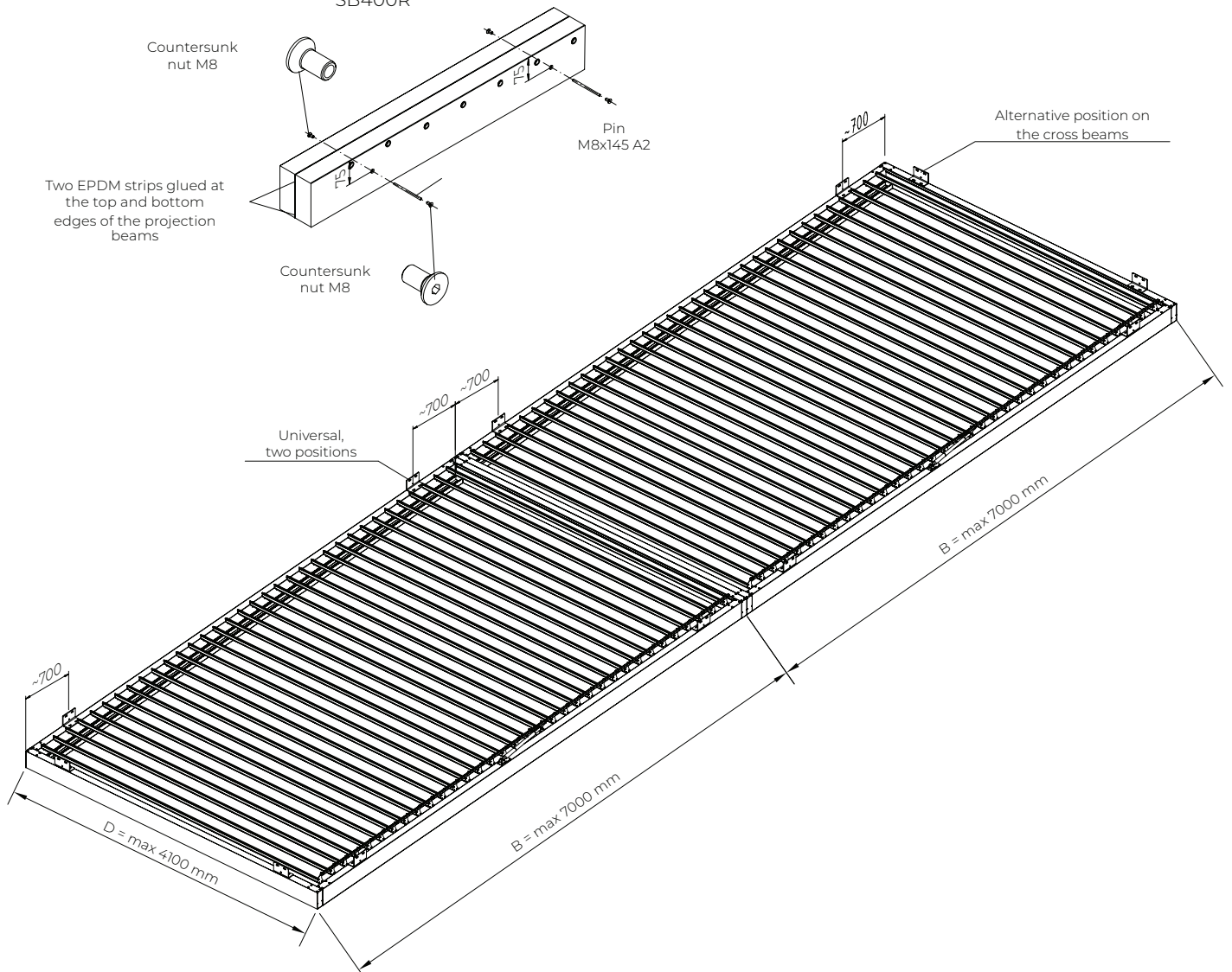

Cross-section of the profiles

Cross-section of the projection and cross beams (85x212)

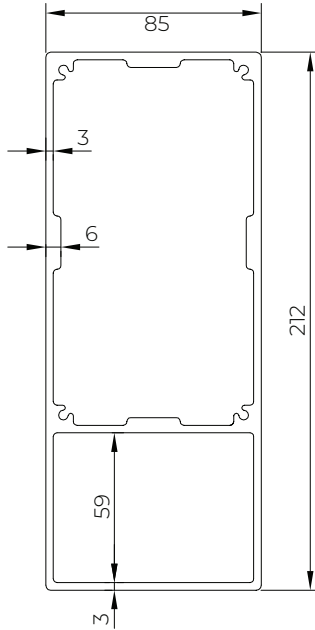

Material: EN AW6060 T66
 Characteristics:
 Mass 6.48 kg/m
 Area 24.01 cm²
 J1 291.31 cm⁴
 J2 1216.58 cm⁴

Cross-section of the post (85x150)

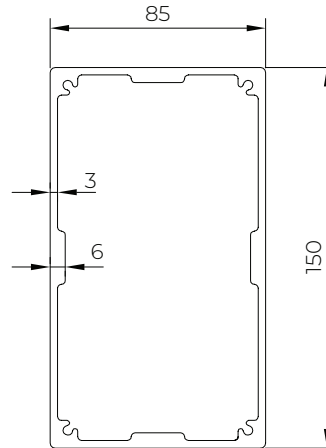

Material: EN AW6060 T66
 Characteristics:
 Mass 4.83 kg/m
 Area 17.89 cm²
 J1 215.9 cm⁴
 J2 564.44 cm⁴

Cross-section of the blade (216x40)

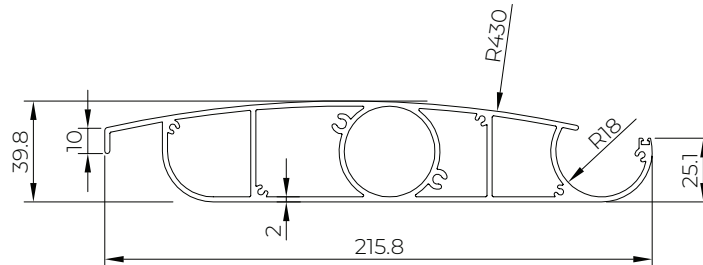

Material: EN AW6063 T66
 Characteristics:
 Mass 3.66 kg/m
 Area 13.57 cm²
 J1 439.1 cm⁴
 J2 27.16 cm⁴

Louvre Roof – Gutters & Drainage

The Louvre Roof is a functional and aesthetic construction set with fixed roof made of rotating blades, which protect against the sun and rain.

Gutters & Drainage

- The louvre roof and posts must be installed level.
- The gutters are installed level.
- Gutters with Splash Dampers are installed into gutters on both projection beams (one each side).
- Water from the gutters drain through a hole at the back of the gutter into the louvre roof post. The post is hollow which allows the water to drain and dissipate at the base of the post. However, in cases where the louvre roof is suspended between an existing structure which may prevent the use of standard louvre roof posts, Window Treatments can install a standard white RB2.65 Marley dropper to the underside of the gutter connected to a Marley downpipe with the water from the downpipe dissipating onto the base of the deck area. If required, the downpipe and associated parts can be painted by Window Treatments to match the colour of the louvre roof gutter. If a connection of the downpipe to the storm water is required, this work is to be carried out by a registered plumber/drainlayer. The cost of this work is not allowed for in the Window Treatments quotation. In addition, the fixing and position of down pipes (if required) may be affected if Securo's are installed into the sides of the louvre Roof so please discuss this with your Window Treatments Sales Consultant prior to placing your order.
- A selection needs to be made at the time of the order, which posts or if Marley down pipes will be used to drain water from the gutters to the ground.
- Small drip profiles (supplementary blades) are installed on both cross beams of the louvre roof. The small drip profiles are designed to deflect any drips from the last louvre closest to the cross beams.
- The louvre roof is weather proof but is not guaranteed to be water tight in adverse or storm conditions. The louvres must be opened when wind exceeds 65km/hr and or when snowing.

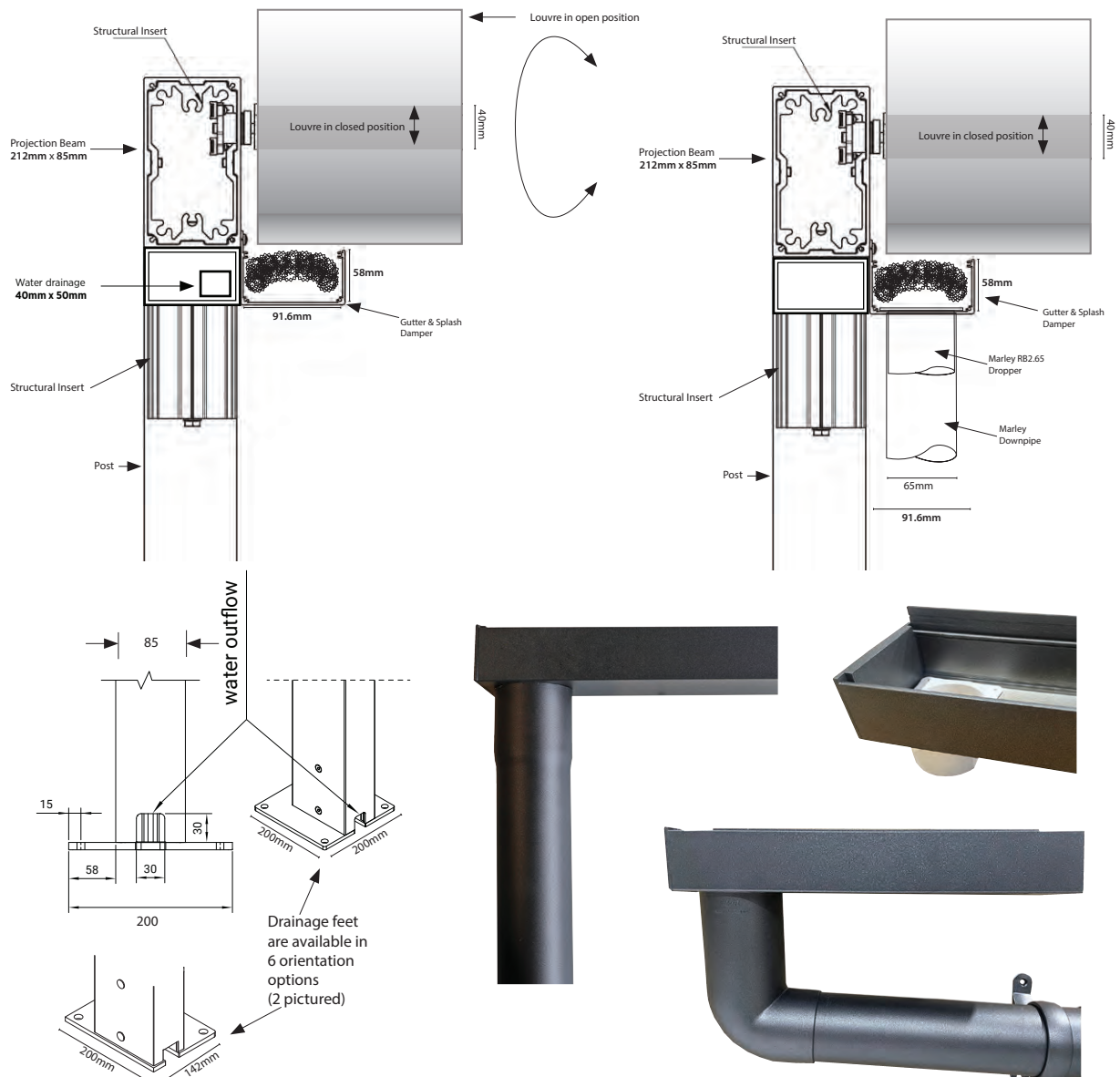

Drainage of the Louvre Roof

NOTE: Required at least 2 posts with water outflow

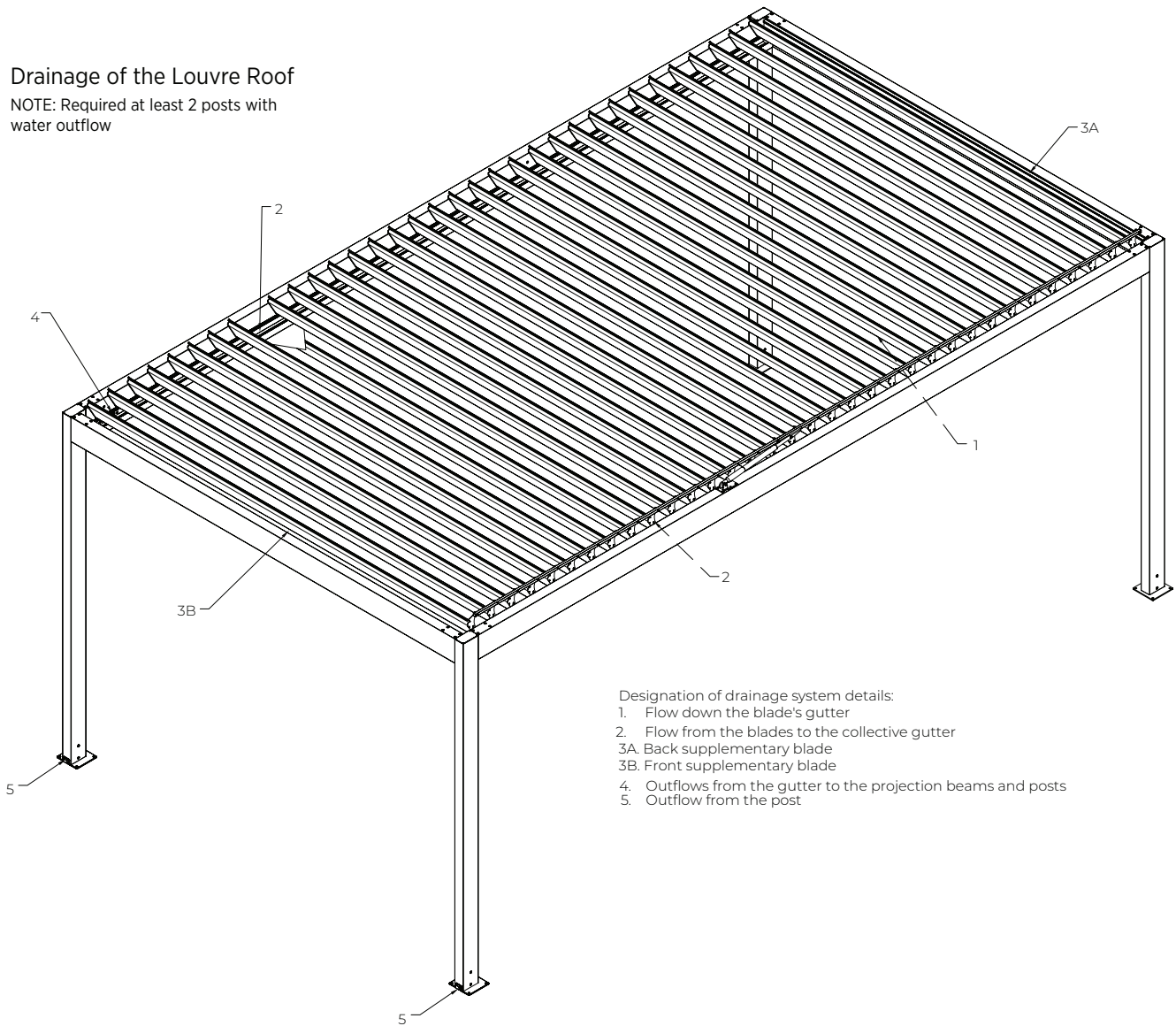

Designation of drainage system details:

- 1. Flow down the blade's gutter
- 2. Flow from the blades to the collective gutter
- 3A. Back supplementary blade
- 3B. Front supplementary blade
- 4. Outflows from the gutter to the projection beams and posts
- 5. Outflow from the post

Detail no. 1

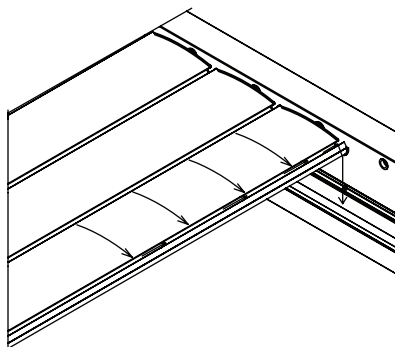

Flow down the blade's gutter into the projection beam gutter

Detail no. 2

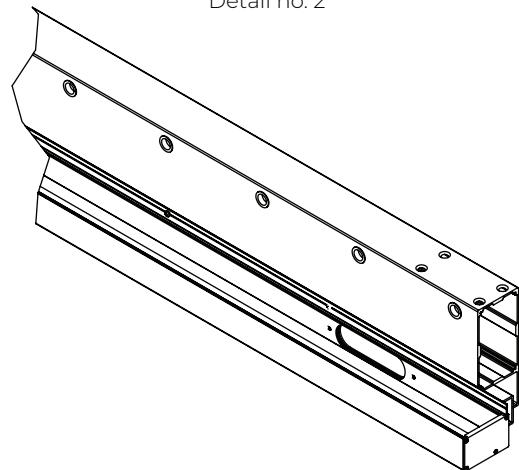

Flow down the gutter into the dropper or post

Drainage of the Louvre Roof

Detail 3

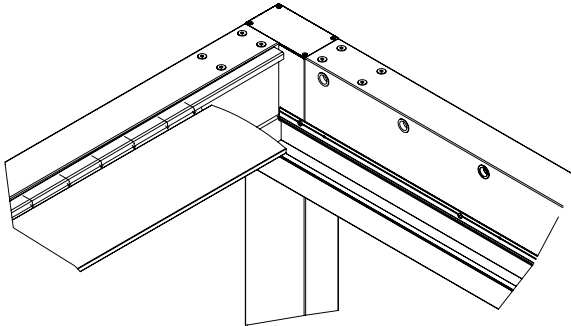

Flow from the back supplementary blade to the blade's gutter. Gutter without slope. NOTE: Extruded gutter as one whole segment.

Detail 4

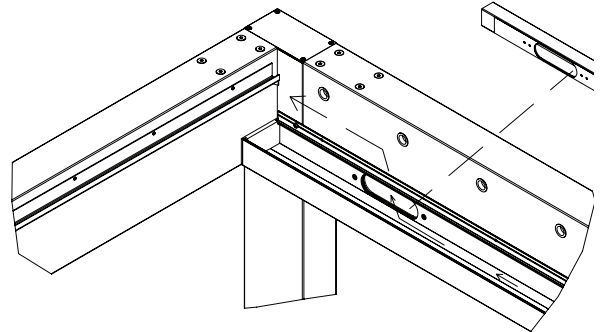

Slotted hole: 144x42 mm
Straight outflow (inside the beam) 34x44 mm.

Detail 5

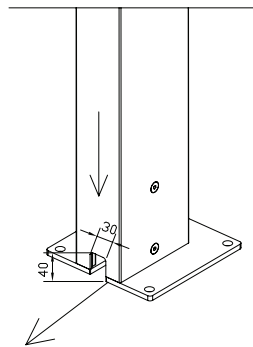

Flow down the beam profile and water outflow at the bottom of the post and foot undercut.

Overflows and outflows in the projection beams

Location of water drainage

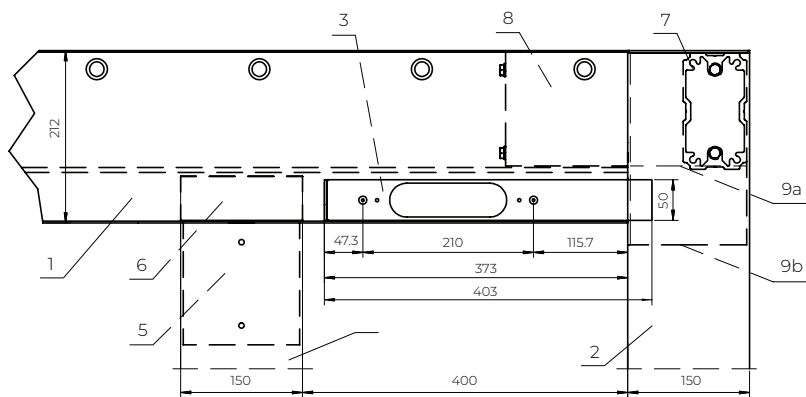

- 1. Projection beam 85x212 mm
- 2. Post 85x150 mm
- 3. Drainage 40x50 mm
- 4. Intermediate post 85x150 mm
- 5. Post connector
- 6. Reinforcing connector
- 7. Structural cross beam connector
- 8. Structural projection beam connector
- 9a. Short angle connector (when draining water)
- 9b. Long angle connector (in case of angle overflow)

Cross-sections of gutters drainage

Cross-section of the gutter (91,6x75)

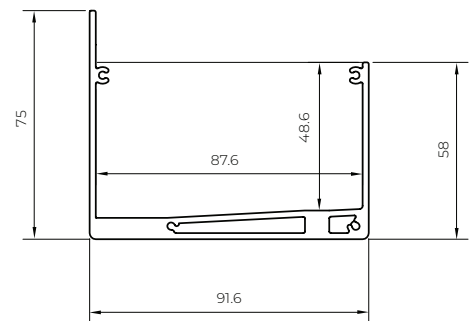

Material: EN AW6060 T66
Mass 7.99 kg/m

Cross-section of the front supplementary blade

Location of angle overflow

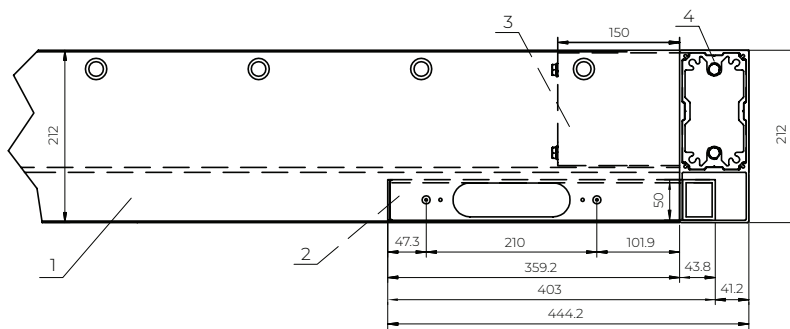

- 1. Projection beam 85x212 mm
- 2. Angle water drainage 40x50 mm
- 3. Structural projection beam connector
- 4. Structural cross beam connector

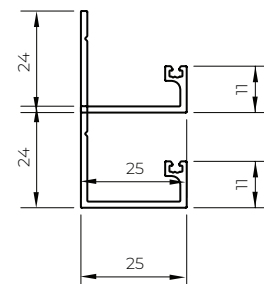

Material: EN AW6060 T66
Mass 0.25 kg/m

Cross-section of the back supplementary blade

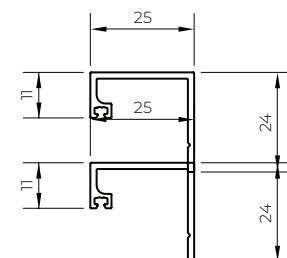

Material: EN AW6060 T66
Mass 0.25 kg/m



SPECIFICATIONS

Louvre Roof – Louvre Direction

The Louvre Roof is a functional and aesthetic construction set with fixed roof made of rotating blades, which protect against the sun and rain.

Choosing the Louvre Direction

Note: For clarity the “Front” of the Louvre Roof as mentioned throughout these Specifications, is when you are facing the Width (Cross) Beam of the planned Louvre roof, with the existing building directly behind it. The same approach is used when specifying the motor or crank side (left or right) of an Awning which is when you are facing the building.

In New Zealand it is generally recommended that louvres lie on an East to West axis irrespective of the rotation direction. This means that the projection beams lie on the North to South axis. Louvre Roofs are primarily designed to provide rain and wind shelter. However, it is important to also consider the shading effect the louvre roof may have over an adjacent building or space and then to maximise or minimise this effect depending on the customers preference.

If sun shading to an adjoining building or space is not desired, we recommend the louvres rotate from the closed position to opening, with the rising side of the louvre (side without the drain), rising to the North, North/West or Westerly direction. This means that the maximum amount of direct sunlight possible will penetrate through the louvres to the ground below.

If sun shading to an adjoining building or space is desired, then the louvres should be facing opposite to the above which will block most direct sunlight.

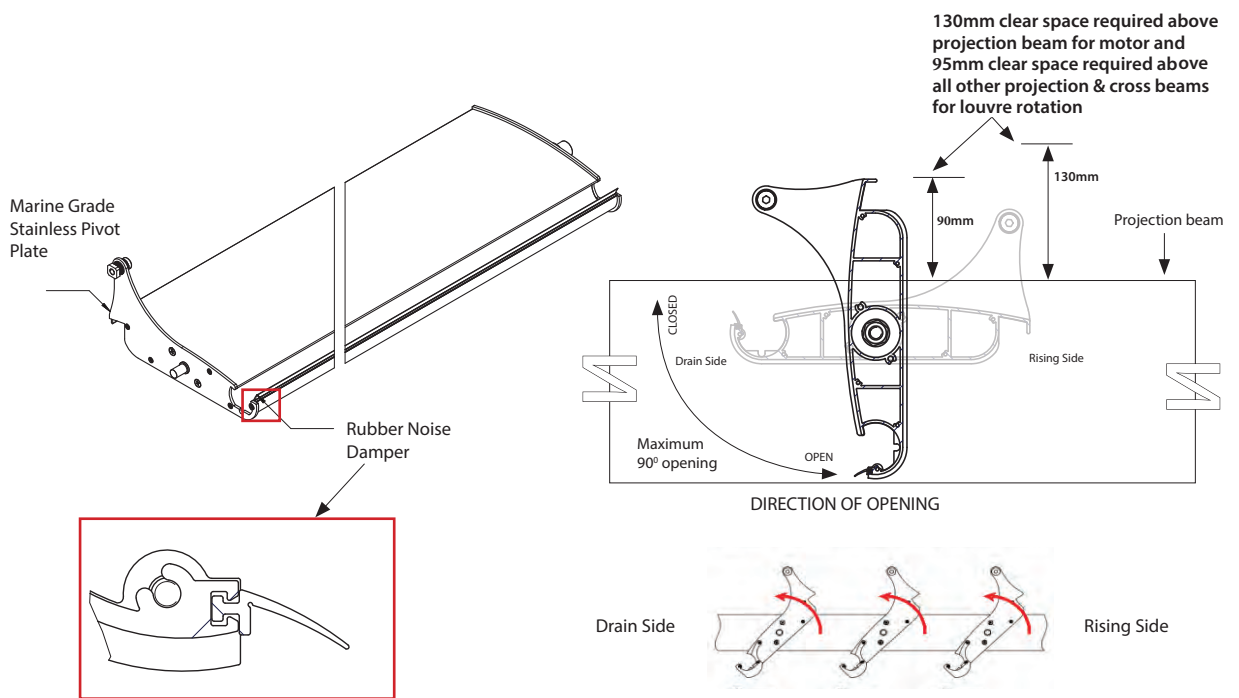

Footing plate options without water outflow

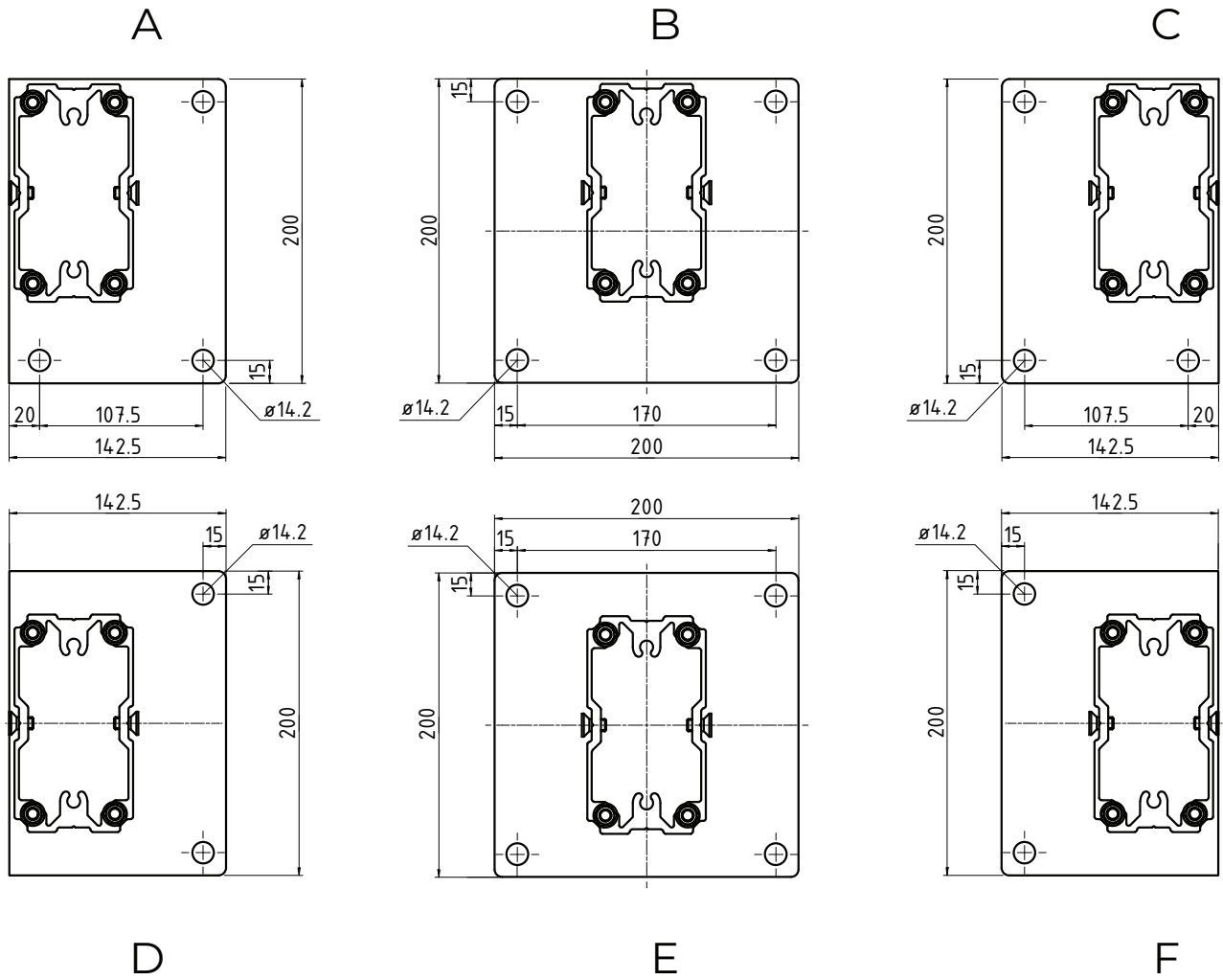

Footing plate options with water outflow

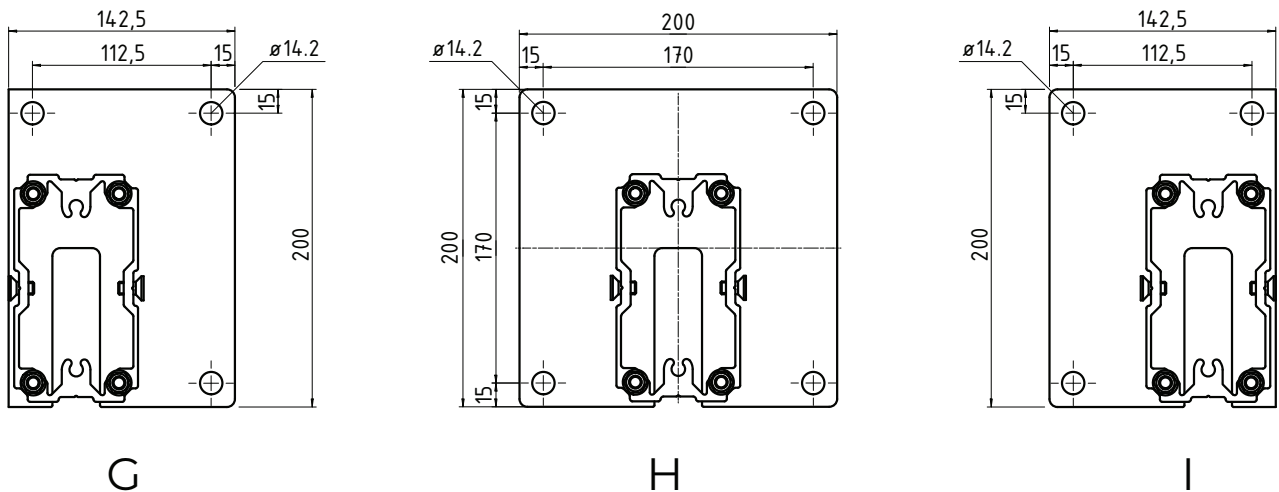

Feet from 8 mm thick aluminium sheet EN AW-5754, galvanized and powder coated

Cross beam detail

NOTE: There are elongated blade mounting shafts on the bearing side.

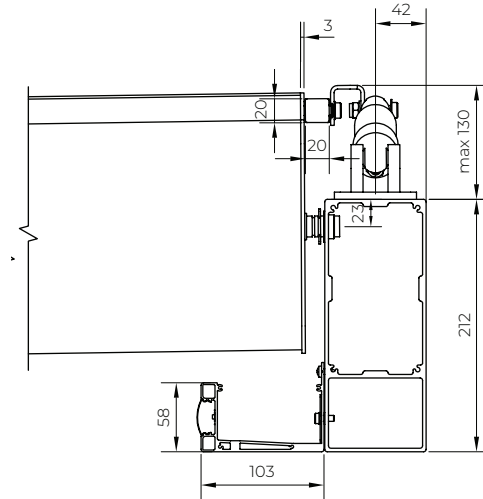

Projection beam detail (bearing side)

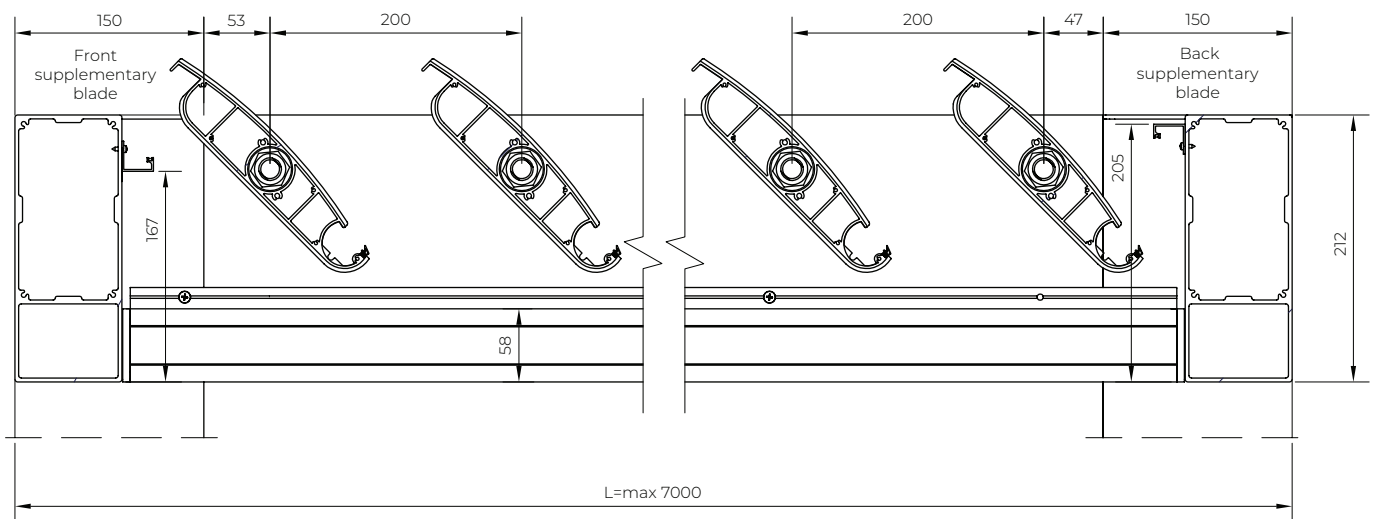

Drive unit, blade rotation range - Pico XL motor 240v

NOTE: The guiding bracket has a left or right version

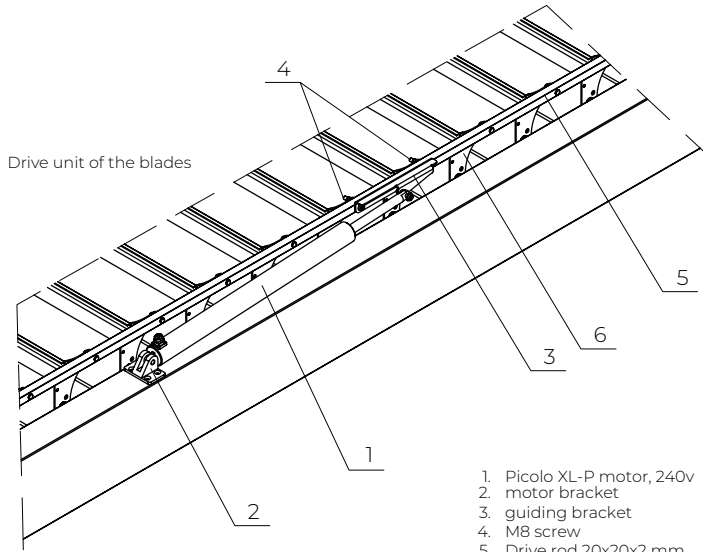

1. Pico XL-P motor, 240v
2. motor bracket
3. guiding bracket
4. M8 screw
5. Drive rod 20x20x2 mm
6. blade end cap (drive side)

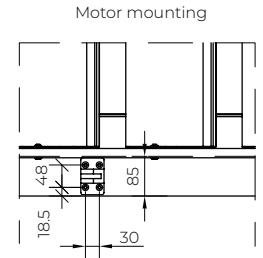
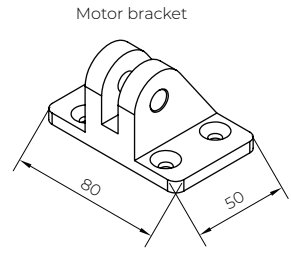

Mechanism and blade rotation range (motor Pico XL-P)

Drive side

Bearing side

Closed blades

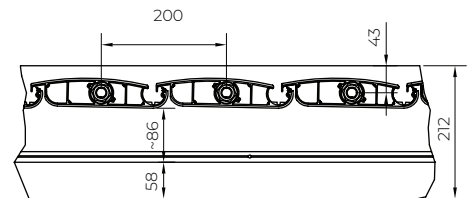
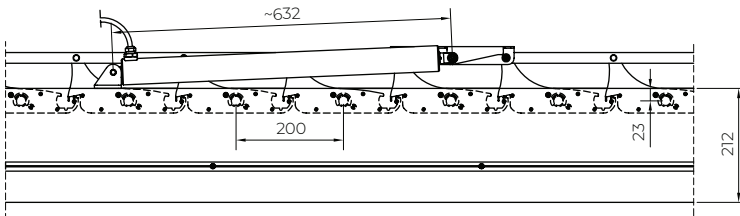

Blades with the maximum height of the motor's drive

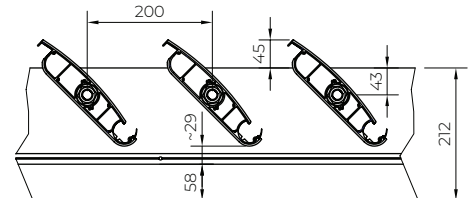
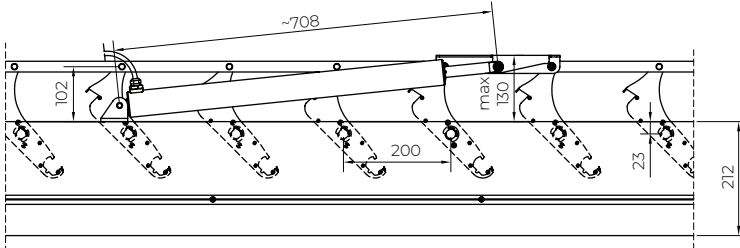

Open

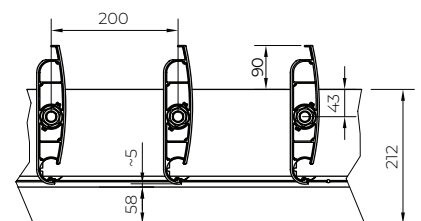
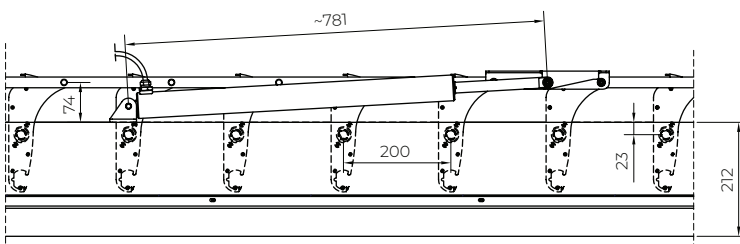

FIXING & FOOTINGS

All fixings and footings must meet NZ building code standards.

- All foundations and or suitable footings are provided by the customer.
- Foundations and footings are required to meet the building code and need to be perfectly level.
- Window Treatments NZ Ltd will secure the louvre roof posts to the foundation/footings provided by the customer.
- The footing plates which are fitted onto the bottom end of the posts, are available in 9 orientations including 6 with drainage holes. A footing plate needs to be selected for each post at the time of the final check measure.
- Face mounting brackets are available for standard installations.
- Additional costs will apply if any special wall mounting brackets or posts need to be engineered to suit a particular application – see pictures D & E take an extra 12 working days lead time

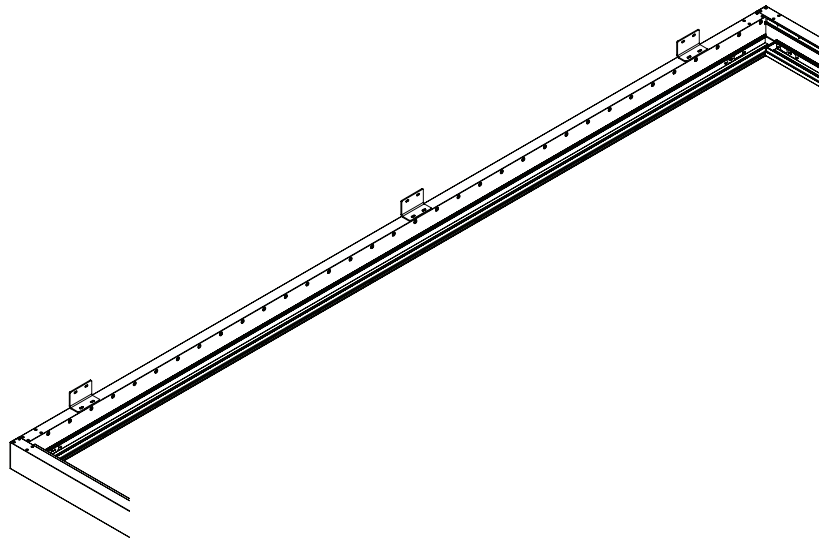

Wall-mounting of the cross beams

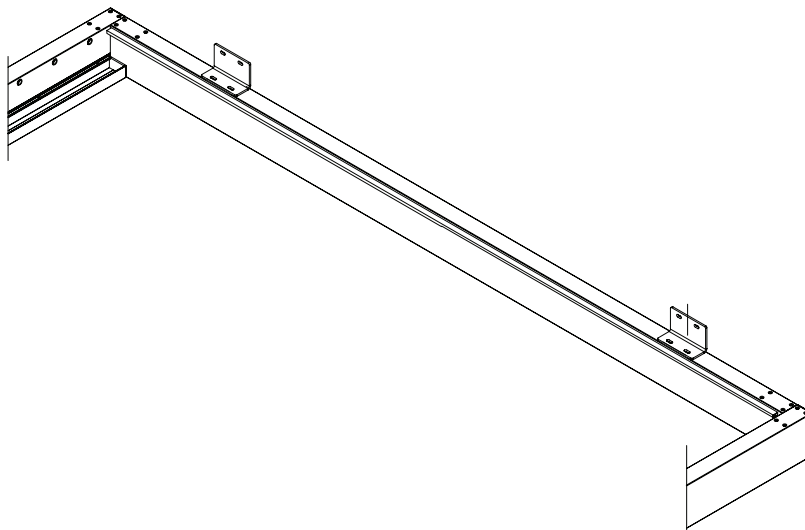

Universal wall brackets

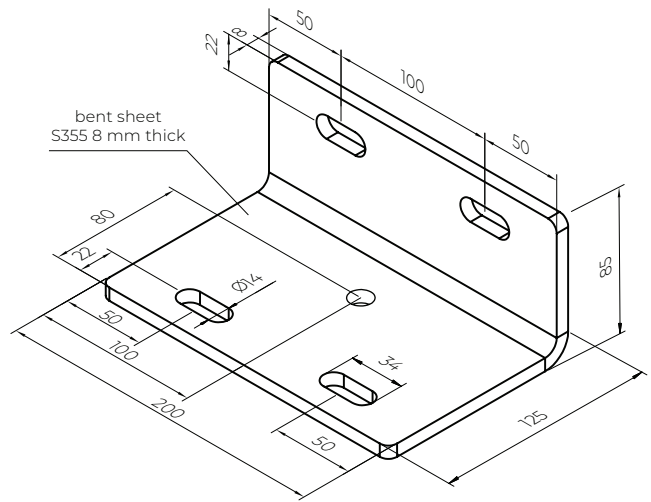
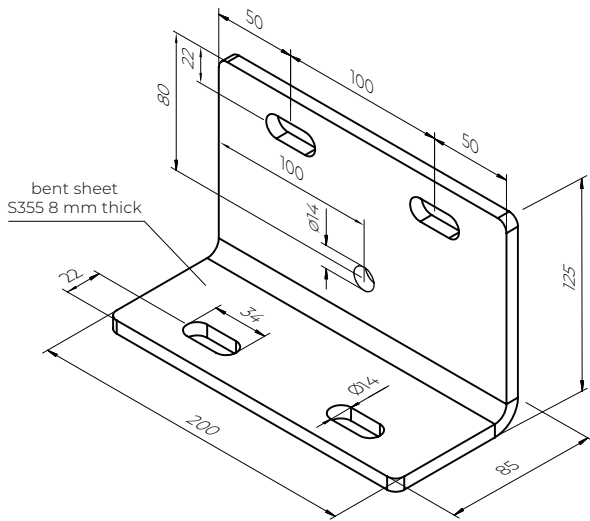

Mounting options with a distance

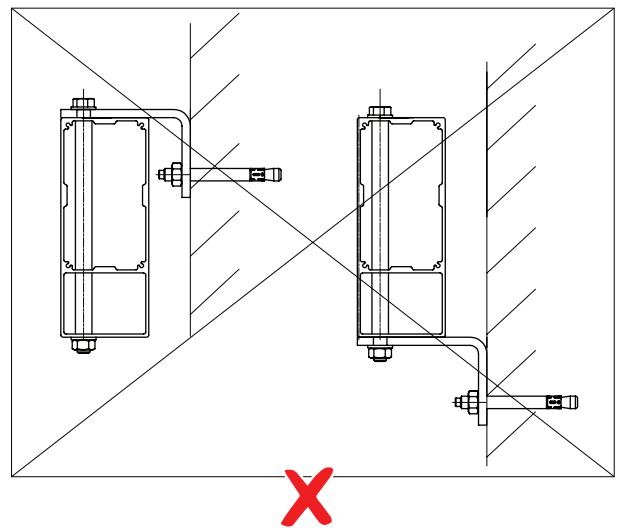
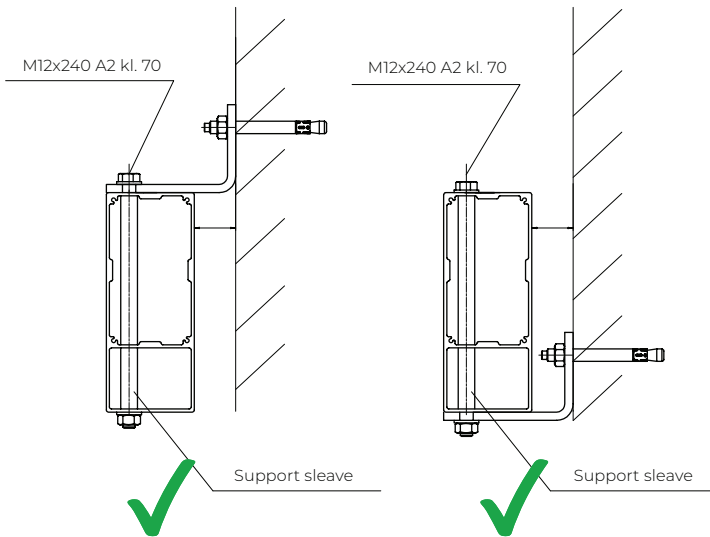

Mounting options without distance

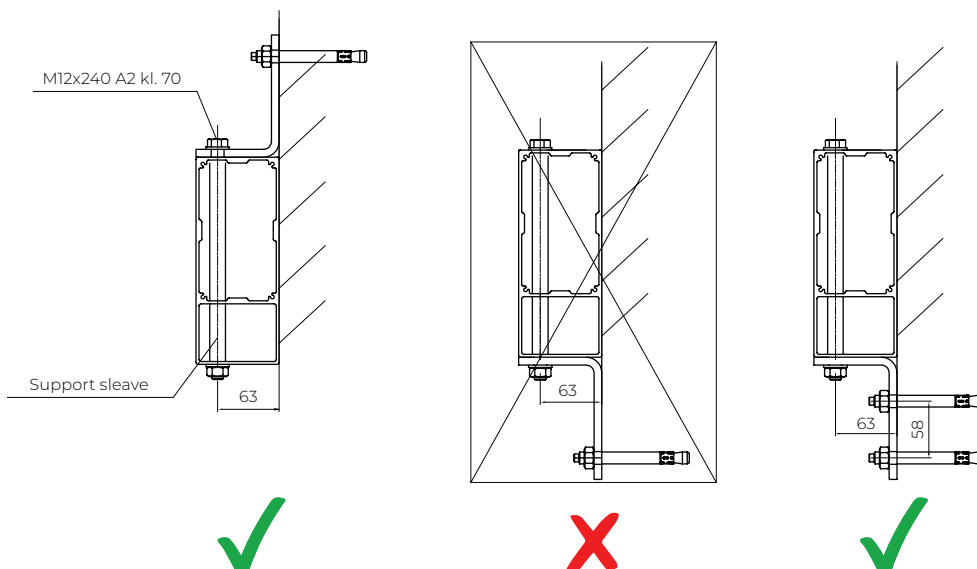



SPECIFICATIONS

ELECTRICAL CONNECTIONS

- The Louvre roof is installed by Window Treatments installers with a 240v Elero Picolo XL-P external motor which is fastened to the middle of the top side, of one of the Projection Beams. The motor has a grey 4m power flex which is to be connected to the power supply by a registered electrician. Window Treatments can recommend an electrician to complete this work if necessary. Power cables and connections can be installed by the registered electrician, inside or outside the hollow Louvre roof beams and posts, however all such work must conform to the Electrical Code.



Drive - Picollo XL-P motor with rod bracket attached

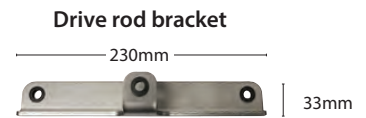
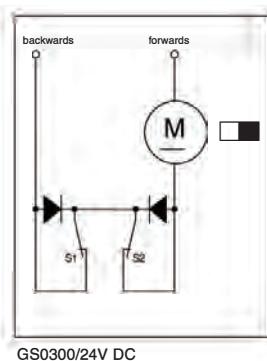
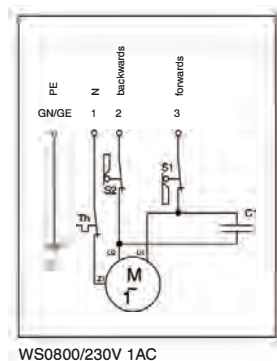

- S1 = Limit switch piston rod out
- S2 = Limit switch piston rod in
- C1 = Capacitor (internal)
- Th = Thermal protection

MOTORISATION

- All Louvre Roofs are motorised with a retro-styled stainless steel 240v Elero Picolla XL-P (German) motor (Manual control is not available).
- Integrated isolation relays enabling parallel connection of several actuators.
- Weather-resistant 230V linear actuator made of stainless steel.
- Additional isolation relays are not required.
- Reduced installation expenditure and higher security against incorrect use.
- Control of several linear actuators in parallel (without synchronisation).
- Motor can be installed on either projection side of the louvre roof but the selected side must be stated on the order.
- Motor is installed on the top of the projection beam (130mm clear space is required above the projection beam the motor is installed upon).
- Louvres in the open position project 90mm beyond the top of the projection and cross beams therefore 95mm clear space must be provided on all beams and cross bars to allow for this rotation.
- Louvres in the open position are flush with the underside of the projection and cross beams.
- Control options are:
 - Somfy Remote with Receiver - optional upgrade with a Connexoon Automation Hub
 - Hard wired to a wall switch or Hard wired to a Post mounted switch
- Wind or Rain Sensors. Note: it is not possible to install both a wind sensor and a rain sensor



Somfy Remote



Post mounted switch



SPECIFICATIONS

Louvre Roof – LED Strip Lighting (optional extra)

With the addition of our 24V LED lighting strips you can illuminate your outdoor living area allowing the opportunity to entertain guests and family during the hours of darkness. Easily controlled via a hand held remote you can change colour, brightness and mode of the lights allowing you to set the tempo of the evening. LED strips are installed just above the louvre gutter on both projection beams.

Features: Product Model SW-F5050RGBCTA30-WFO

- Power supply 24V
- Power consumption 14.4 watt per metre
- IP Rating IP68
- Working Environment Temperature -25 to +450C
- Various Lengths available up to 7m
- Max connection length off one controller: 14m
- LED: quantity 60pcs per metre
- LED strip diffuser

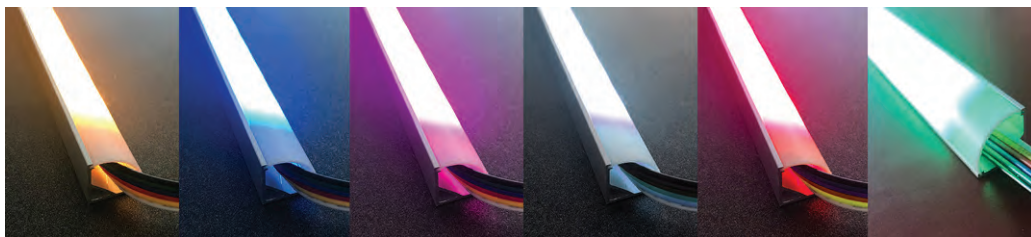

Dimensions:

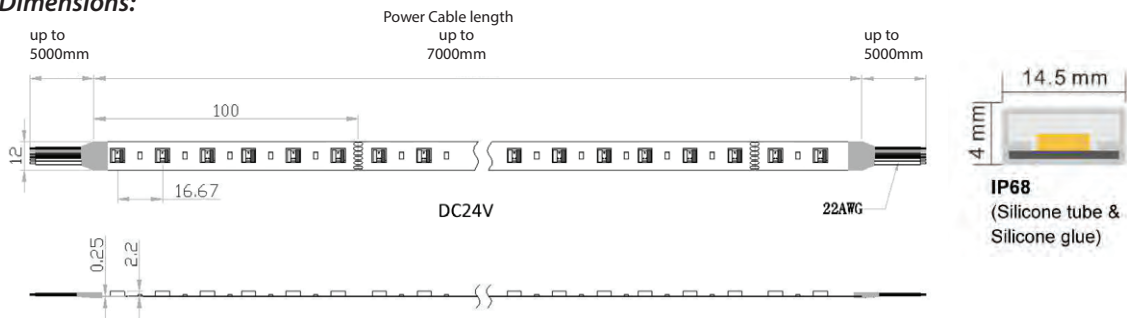

Rainbow Controller with 4 Zone Remote Control 2.4G

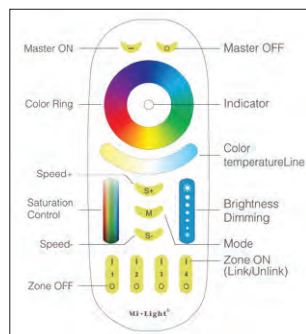

Optical Lux Graph

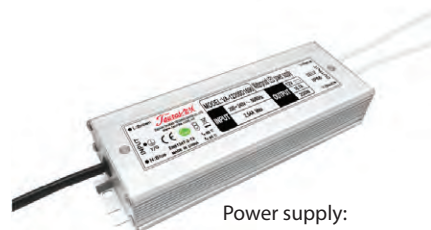
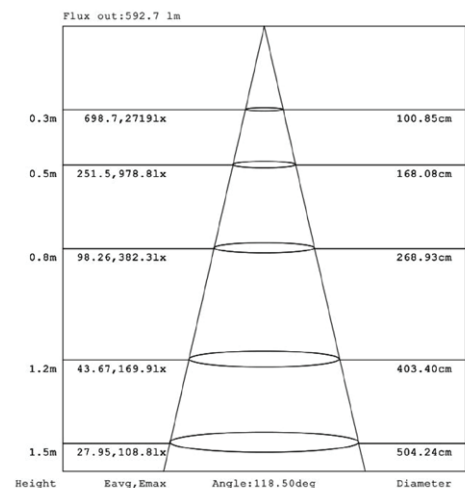

Power supply: Constant Voltage 24VDC 200w IP66

Louvre Roof - Securo® Outdoor Blinds

SECURO® 110

- Motorised or Manual (crank) options
- Available in both PVC and Screen fabric and can be installed on all four sides of the louvre roof.
- Installation of Securo 110 can be inside (top fix) the beams and posts or face mounted on the outside of the beams and posts. Note: For face fix installations we recommend motorised Securo's for ease of operation.
- Maximum size with Techno Screen: W5.1m x D3.0m
- Maximum size with Clear PVC: W4.0m x 3.0m

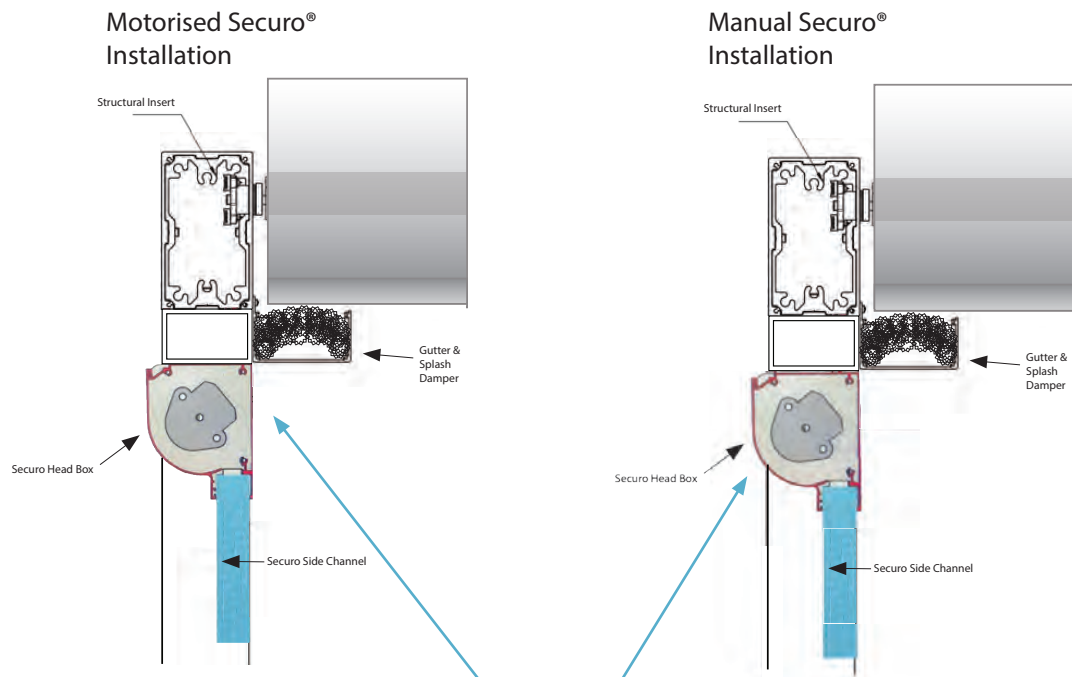

Note: The Head Box and side channels can be inverted so that the curved fascia faces inside rather than outside.



Louvre Roof - Securo® Outdoor Blinds

SECURO® MAX

- Motorised
- Available in Techno X Screen fabric and can be installed on all four sides of the louvre roof.
- Installation of Securo Max can be inside (top fix) the beams and posts or face mounted on the outside of the beams and posts.
- Maximum size with Techno Screen: W10.0m x D3.0m

Motorised Securo® Max Installation

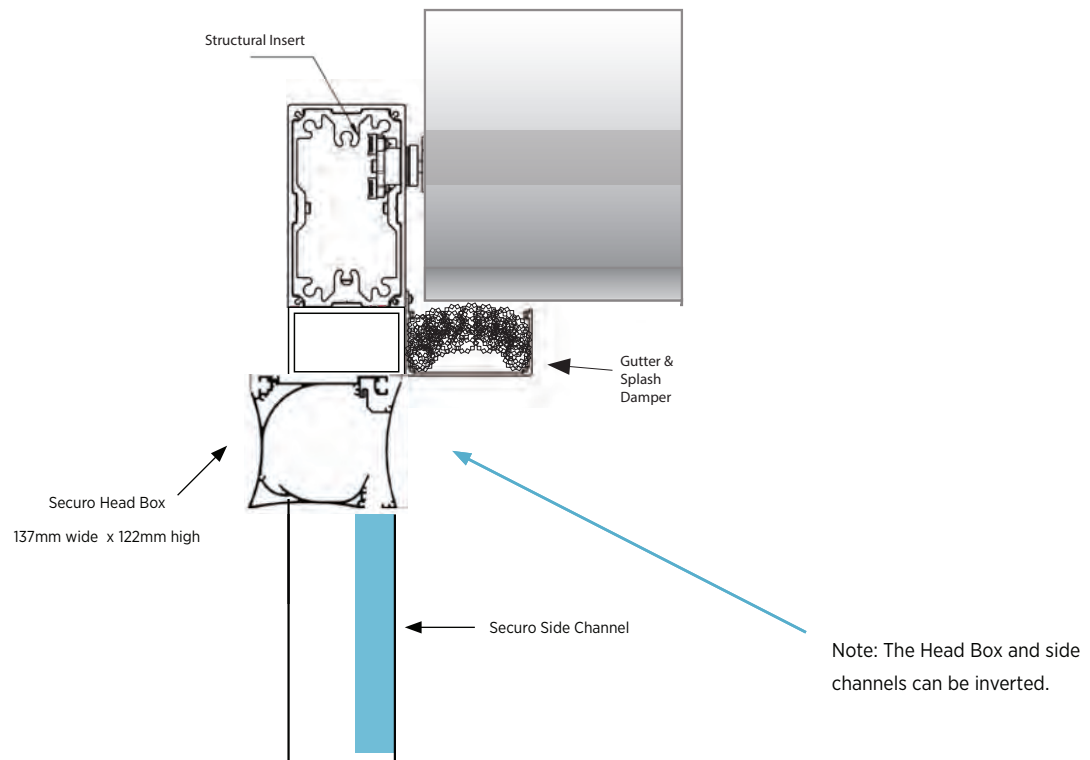

Louvre Roof - Securo® Outdoor Blinds

SECURO® PULL DOWN

- Manual system and can be installed on all four sides of the louvre roof.
- Operated easily by raising and lowering the blind using the handle or pull cord located on the bottom rail. Fabric tension is created with a spring inserted in the top tube within the cassette housing and the blind can be locked into the down position by simply tilting the bottom rail.
- Installation of Securo Pull Down can be inside (top fix) the beams and posts or face mounted on the outside of the beams and posts.
- Available with Phifer FR Patio Insect Screen or Soltis 88 exterior screen.
- Maximum size with 60mm x 60mm housing with Phifer FR Patio Insect Screen: W2.40m x W2.0m Drop
- Maximum size with 80mm x 80mm housing with Soltis 88 block out is W2.7m x D2.55m.

Securo® Pull Down (Manual) Installation

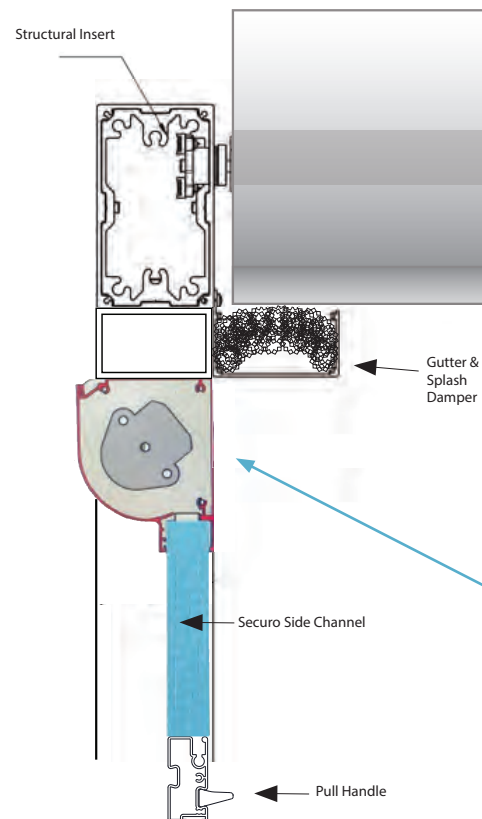

Note: The Head Box and side channels can be inverted so that the curved fascia faces inside rather than outside.



Louvre Roof - Securo® Outdoor Blinds

SECURO® SIDE ROLL

- Securo Side Roll (manual system)
- Available with Phifer patio insect screen and can be installed on all four sides of the louvre roof.
- Maximum size with Phifer patio insect screen: Single Screen - W4.0m x D2.7m, Double Screen - W8.0m x D2.7m.

Securo® Side Roll Installation

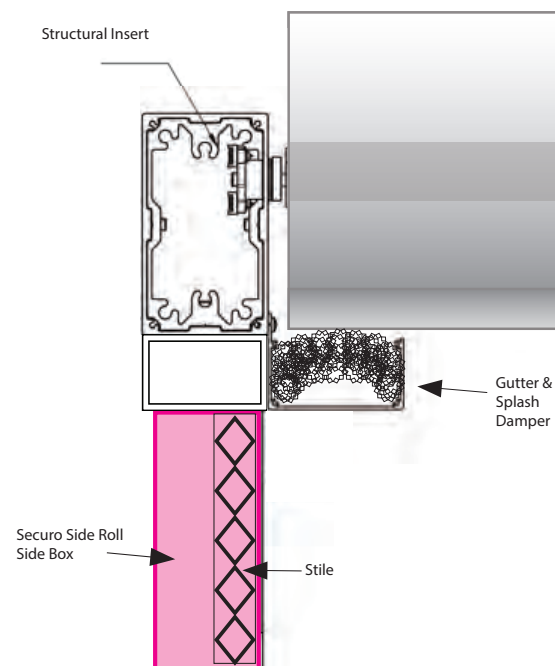

SPECIFICATIONS



Louvre Roof – Product Operation, Owner Maintenance Guide & Warranty

PRODUCT OPERATION

Your installer will fully explain the operation of your Window Treatments Louvre Roof. Control of your louvre roof is either via a handheld remote, hardwired switch, or an automation system.

Ensure before opening or closing of the louvres there are no obstructions such as branches or debris that prevent the louvres from rotating freely.

The louvre roof is weather proof but is not guaranteed to be water tight in adverse or storm conditions. The louvres must be opened when wind exceeds 65km/hr and/or when snowing.

OWNER MAINTENANCE

Louvre Roofs installed in coastal areas require additional care by the owner to minimise deterioration and corrosion. For coastal areas we recommend regular (6 monthly) lubrication and cleaning of drives, metal parts and all components.

In addition, we recommend regular (monthly) removing & cleaning of all debris from the louvre roof gutters and louvres.

WARRANTY

1. The Company (Window Treatments NZ Limited) warrants that it will repair or make good any defects in materials or workmanship brought to its notice within a three-year period from the date of installation.
2. Following notice of a warranty claim, the Company shall have the right at a time convenient to both parties, to inspect the product.
3. If notice is not given within this three-year period the claim shall be deemed to have been waived.
4. No claim shall be accepted if any attempt to repair the defective goods is made by any person or persons not authorised by the Company to complete the repairs.
5. No claim shall be accepted if the defective goods have been modified or incorrectly maintained or incorrectly operated (refer to Product Operation & Owner Maintenance Guide).
6. Claims after the three-year warranty period will be charged at the normal labour and travelling rates at the time of the claim, plus the cost of any parts or components required.
7. Blinds, Securo's, Shutters, Awnings, Louvre Roofs and Insect screens installed in coastal areas will require additional maintenance by the owner to minimise deterioration and corrosion. For coastal areas we recommend regular (6 monthly) lubrication and cleaning of chain drives, metal parts and all components.
8. For Louvre Roofs in addition to clause 7 above, we recommend regular (monthly) removing & cleaning of all debris from the louvre roof gutters and louvres (refer to Product Operation & Owner Maintenance Guide).
9. Failure to clean and maintain products as per clauses 4, 7 & 8, will void the three-year warranty.

SPECIFICATIONS



Securo®



SPECIFICATIONS

Securo® Overview



Securo® is an Italian designed specialised roller blind with 7 models. The main function of Securo® is to provide shelter from the elements: wind, rain, sun and heat. Depending on which Securo® model suits your requirements, the Securo® can be installed either as an exterior or interior product.

The key to this innovative robust interior/exterior Securo® product is how the fabric is locked (Securo®) into the roller tube, channel guides and bottom aluminium rail. This locking method ensures that the fabric is held in place during inclement weather. The Securo® Pull Down, Channel Guide 75 & 110 systems have been designed for winds up to 65km/h and Securo® Max (up to 4.6m wide) is designed for winds up to 65km/h (over 4.6m wide) is designed for winds up to 35km/h.

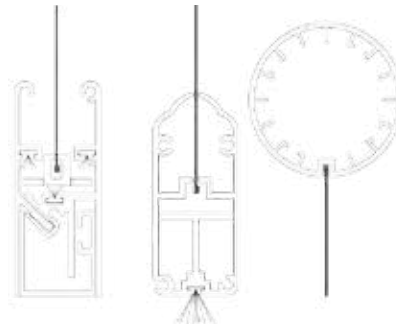

Channel Guide Bottom Rail Roller Tube

The versatility of Securo® provides for various control options such as crank, chain or motorisation with a variety of different head box sizes and an optional stainless steel wire guide.

These robust features and the fully enclosed head box to protect the fabric, makes Securo® the most advanced and stylish interior/exterior roller blind on the market.

Model Types:	Application:	Maximum Width Guidelines (Width)	Operation:
Securo® Pull Down	Interior & Exterior	2.4m - 2.7m	Manual - Handle
Securo® Channel Guide 75	Interior	3.9m	Motorised, Crank Handle
Securo® Channel Guide 110	Interior	4.6m	Motorised, Crank Handle
Securo®Max Channel Guide	Interior	10m	Motorised
Securo®Max Wire Guide	Interior	10m	Motorised
Securo® Channel Guide 75	Exterior	3.9m	Motorised, Crank Handle
Securo® Wire Guide 75	Exterior	3.9m	Motorised, Crank Handle
Securo® Channel Guide 110	Exterior	4.6m	Motorised, Crank Handle
Securo® Wire Guide 110	Exterior	4.6m	Motorised, Crank Handle
Securo®Max Channel Guide	Exterior	10m	Motorised
Securo®Max Wire Guide	Exterior	10m	Motorised
Securo®Side Roll	Interior/Exterior	4.0m	Manual - Side Pull with Brake

Applications:

Interior - Selecting from a variety of fabrics such as Sunscreen, Light-filtering, Block-out or Insect Screen, Securo® blinds are ideally suited to computer rooms, offices, home theatre, room dividers and bedrooms. Securo® blinds offer insect control, sun and heat control and when required a complete block-out to a room.



Operation:

Securo® has 4 options for raising and lowering:

1. **Handle** - Securo® Pull Down is controlled manually by pulling up and down using a handle on the bottom rail.
2. **Crank** - Securo® Channel and Wire Guide (75 & 110) for internal or external applications are controlled by a crank handle. For security reasons or to stop an unwanted guest operating the Securo®, a magnetic cardan joint crank handle allows for the easy removal and storage of the crank handle whilst not in use.
3. **Motor** - for both Securo® and Securo® Max Channel and Wire Guide systems which can be linked to a building management system or remote controlled with optional light and wind sensors.
4. **Manual side-pull with brake** - Securo® Side Roll



Securo® Pull Down

Securo® Pull Down Blind

Securo® Pull Down blinds are designed for small to medium sized interior and exterior windows and doors providing solutions for Insect control, complete block-out, glare control and protection from wind and rain.

The key to this innovative robust interior & exterior roller blind is how the fabric is locked (Securo®) into the roller tube within the aluminium cassette housing, bottom rail and side channel guides. The Securo Pull Down incorporates a locking spline which is welded to the fabric on all four sides using a high impulse electric welding machine. The fabric is guided into the head and bottom rails and side channels through a specially formed locking groove.

Securo® Pull Down is easily operated manually, by raising and lowering the blind using the handle or pull cord located on the bottom rail. Fabric tension is created with a spring inserted in the top tube and the blind can be locked into the down position by simply tilting the bottom rail.

These robust and versatile features makes Securo® Pull Down the most advanced channel roller blind system on the market for small to medium sized windows and doors.

Application : Interior & Exterior

Maximum Sizes for 60mm Housing system:

Phiferglass Pool & Patio Mesh - 2400mm wide x 2000mm Drop
Block Out (interior) & Screen fabric (Soltis 88) – 2100mm wide x 2000mm Drop

Minimum Sizes for 60mm Housing system:

Phiferglass Pool & Patio Mesh - 450mm wide x 450mm Drop

Maximum Sizes for 80mm Housing system:

Phiferglass Pool & Patio Mesh - 2700mm wide x 2550mm Drop
Block Out (interior) & Screen fabric (Soltis 88) – 2700mm wide x 2550mm Drop

Minimum Sizes for 80mm Housing system:

Phiferglass Pool & Patio Mesh - 600mm wide x 600mm Drop

Operation

: Manual

Fixing

: Top or Face Fix

Fabric options

: Exterior : Phiferglass Pool & Patio Mesh, Soltis 88 Screen

Interior : Phiferglass Pool & Patio Mesh, Soltis 88 Screen,

Icon FR Block-out, Duo Block

Note: not suitable for Clear PVC

Cassette Housing

: Aluminium 60mm x 60mm & 80mm x 80mm fully enclosed 2 piece cassette aluminium head box protecting the roller tube and fabric.

Standard Colours for Aluminium Profiles : Gun Metal, Perla, White, Matte Black, and Custom



SPECIFICATIONS

Securo® Pull Down



SPECIFICATIONS

1a. 60mm Cassette Housing

2a. Tube : Aluminium Ø35mm Securo® Locking Groove

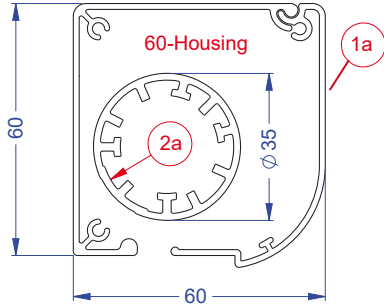

1b. 80mm Cassette Housing

2b. Tube : Aluminium Ø48mm Securo® Locking Groove

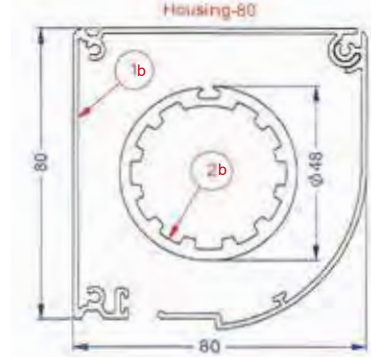

3a. Bottom Rail for 60mm housing system : Aluminium
1 piece 21mm x 45mm Securo® locking Groove
with Soft Touch

Note: For Face Fix installations an additional profile (fig 6) is required.

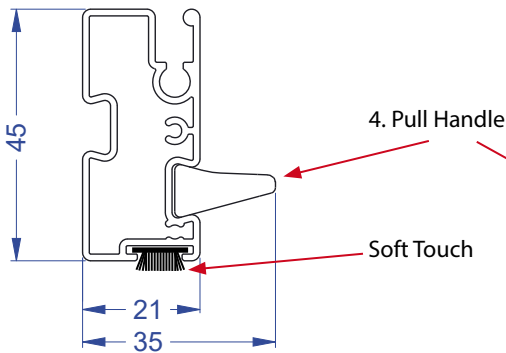

3b. Bottom Rail for 80mm housing system : Aluminium
1 piece 21mm x 45mm Securo® locking Groove with
Soft Touch

Note: For Face Fix installations an additional profile (fig 6) is required.

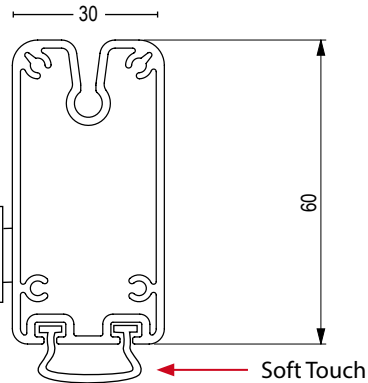

5. Side Channel Guide for 60mm & 80mm Cassette Housing versions

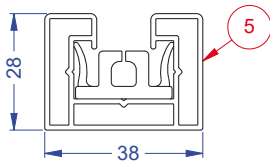

6. Sill (Installations where there is no sill to drop the bottom rail onto). For 60mm & 80mm Cassette Housing versions

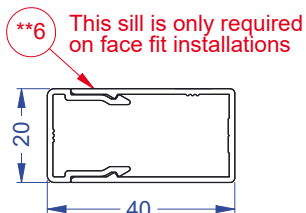

7. Side Channel Packer for 60mm & 80mm Cassette Housing versions

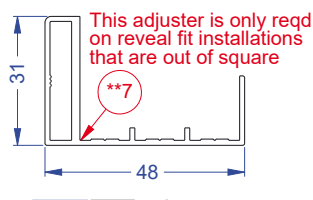

Standard Colours for Aluminium Profiles : Gun Metal, Perla, White, Matte Black, and Custom

Sec. : Securo
Date : Aug 2022

Cross Section of typical Face Fix installation:

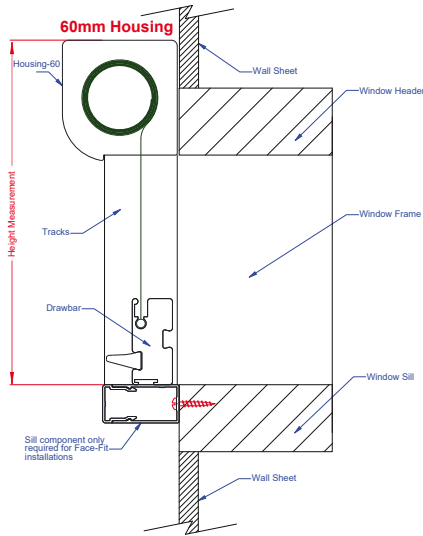

Cross Section of typical Top Fix installation (inside fit):

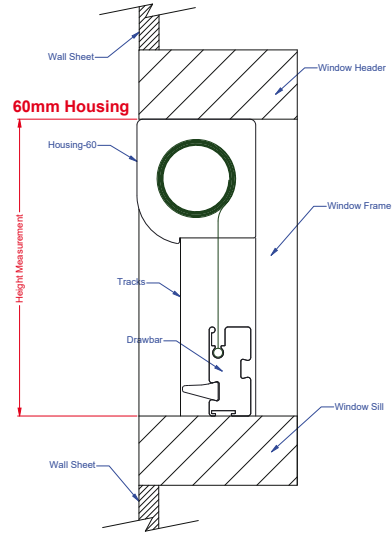

80mm Housing

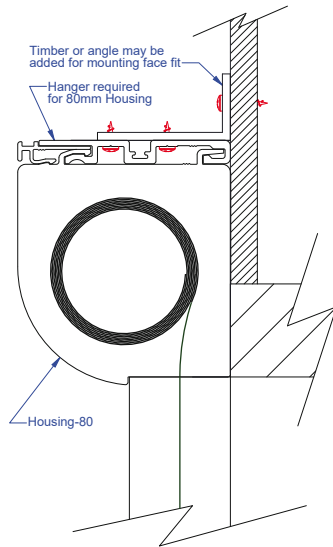

80mm Housing

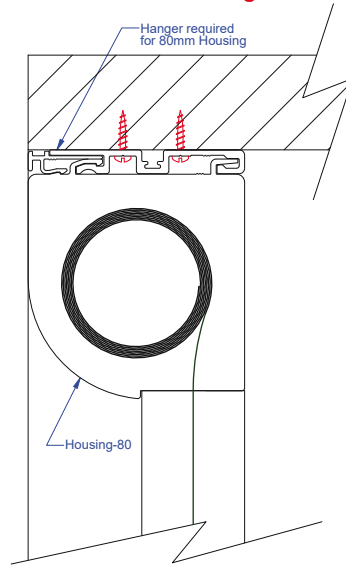

Plan view of Face Fix:

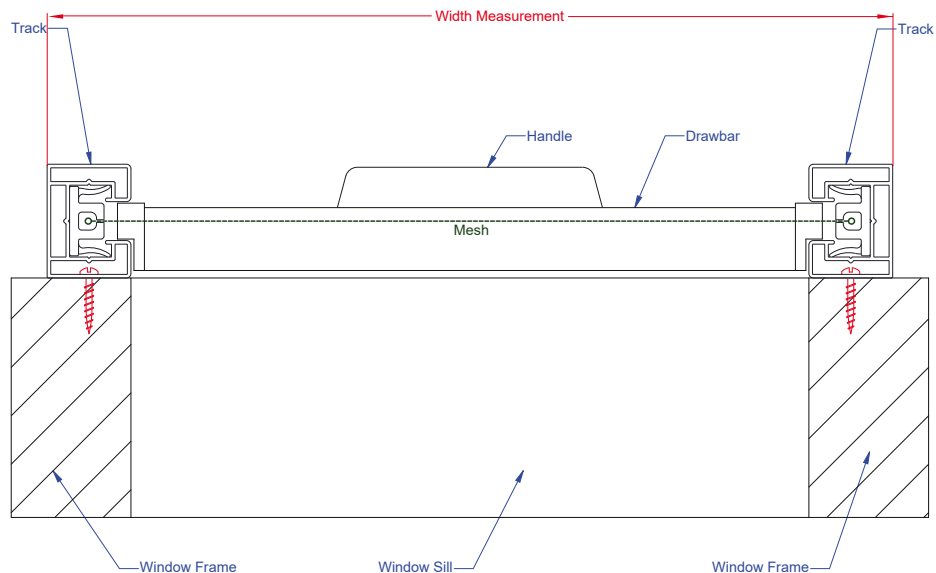

Securo® Pull Down



Plan view of Top Fix (inside fit):

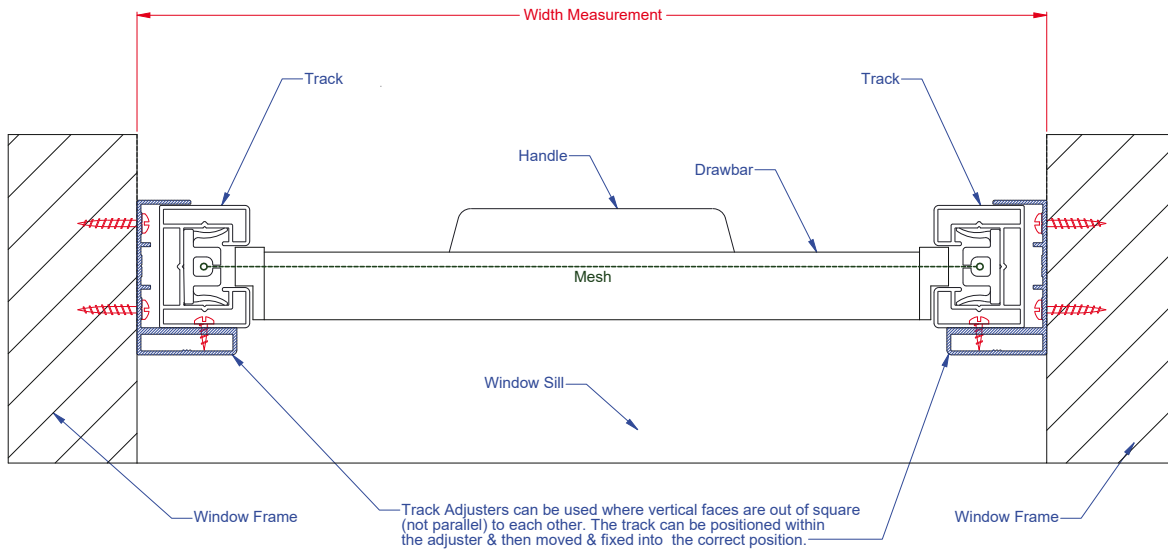

Example for Corner installations:

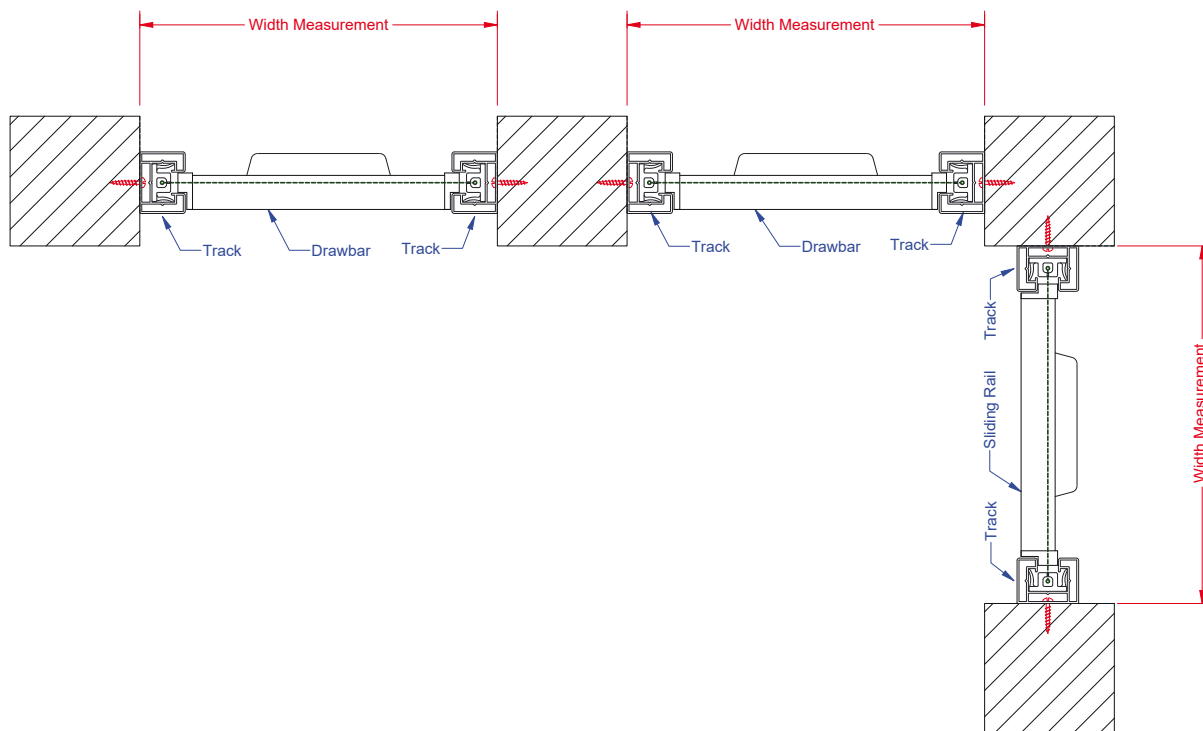

SPECIFICATIONS

Sec. : Securo
Date: Sep 2020

Securo® - Channel Guide 75 & 110

SPECIFICATIONS

Securo® Channel Guide 75, Securo® Channel Guide 110

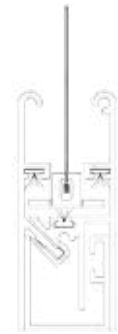
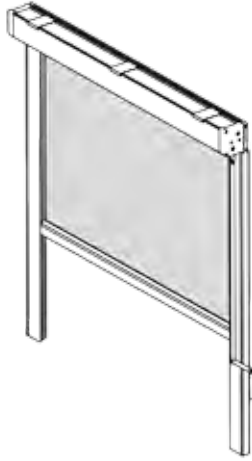

Channel Guide



Bottom Rail



Roller Tube

- Application** : Interior or Exterior
- Maximum Size** : For Securo Channel Guide 75 - 3.9m wide x 1.3m drop (drop subject to fabric selection)
 For Securo Channel Guide 110 - 4.6m wide x 3.0m drop (drop subject to fabric selection)
- Operation** : Crank Handle or Motorised
 Securo® Channel Guide can be linked to a building management system, remote controlled and with wall switches with optional light & wind sensors



- Fixing** : Top or Face Fix
- Material Type (Interior)** : Sunscreen, Light-filtering, Block-out
(Exterior) : Techno X
- Head Box Options**
- 110mm x 138mm 2 piece cassette is recommended for use with all fabrics including clear PVC. The two piece cassette box provides ease of maintenance and assembly.
 - 75mm x 75mm 1 piece cassette for narrow reveals recommended for all fabrics except PVC.
 - All fascia panels have a 7mm diameter drainage hole at each end of the fascia

138mm x 110mm

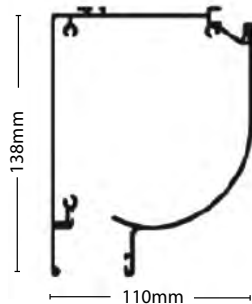

75mm x 75mm

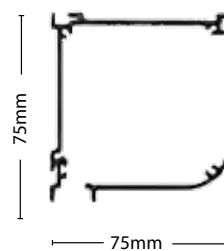

- Tube** : Outer Tube Options:
 Aluminium Ø63mm,
 Steel Ø70mm (steel tube for motorised blinds only)
 Inner Tube Ø40mm
 Inner Motorisation Tube Ø40mm
 Securo® Locking Groove

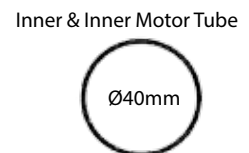
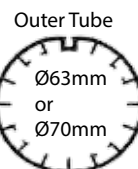

Securo® - Channel Guide 75 & 110



Channel Guide : Aluminium
 4 pieces on each side
 Securo® Locking Groove
 Lip Seal
 Face Fix 33mm x 63mm
 Side Fix 25mm x 63mm

Side Fix

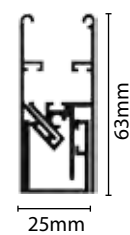

or

Face Fix

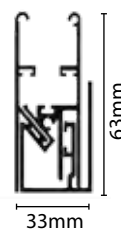

Channel Guide Optional : Aluminium
 2 pieces on each side
 PVC only
 No Securo® Locking Groove
 Lip Seal

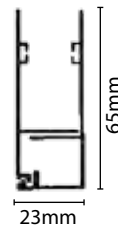

Bottom Rail : Aluminium
 1 piece
 Securo® Locking Groove
 Lip Seal
 Soft Touch

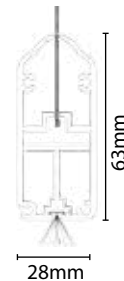

Securo® Gear : Case : Zinc Aluminium
 Screw Worm : Aluminium
 Crown : Brass
 Gear Ratio : 5/5
 Nickel Brass Magnetised Cardan Joint complete with bell coupling

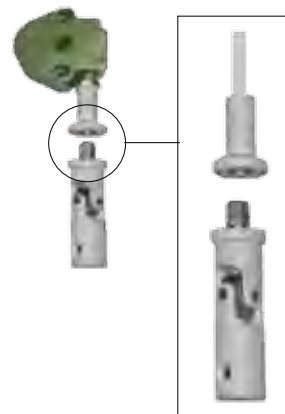

Crank Handle : Crank Handle with aluminium tube
 Colours available: White, Black



SPECIFICATIONS

Sec. : Securo
 Date : Nov 2018



Securo® - Wire Guide Options

SPECIFICATIONS

Securo® Wire Guide Options

Crank Handle 90° transmission through frame : Nickel Brass Cardan Joint complete with bell coupling
Nylon Case
Colours available: White, Black



Crank Handle Magnetic Cardan Joint : Colours available: White, Black

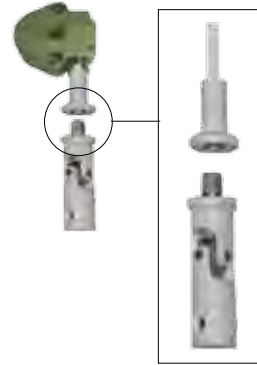

Fixed Crank Handle Holder : Nylon Case
Colours available: White, Black



Securo® Wire Guide 75, 110

Available in 2 sizes:

Size:
Securo® Wire Guide 75
Securo® Wire Guide 110

Maximum Width:
3.9m
4.6m

Operation:
Crank Handle or Motorised
Crank Handle or Motorised

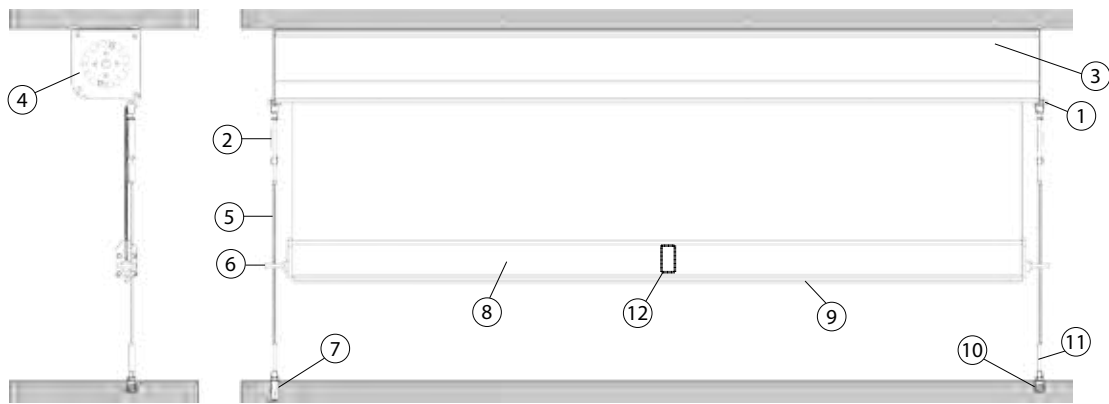

Key Numbers

- | | |
|---|---------------------------------------|
| 1. Eyelet | : Stainless Steel 316 |
| 2. Jaw/Swage Pipe Turnbuckle | : Stainless Steel S3121P M6/3.0 |
| 3. Head Box | : Aluminium |
| 4. End Cap | : Powder Coated over Galvanised Steel |
| 5. 3mm Stainless Steel Cable Wire | : Stainless Steel 7 x 19 ASIST316 |
| 6. Eye Bolt | : Stainless Steel 316 |
| 7. Drop in Anchor (Concrete Fixing) | : Stainless Steel 316 |
| 8. Bottom Rail | : Aluminium |
| 9. Soft Touch | : Polybond Woolpile |
| 10. Counter Sunk Socket Screw (wood fixing) | : Stainless Steel 316 |
| 11. Swage Stud | : Stainless Steel S7801 3mm x M6 316 |
| 12. Stabilising Bolt (optional) | : Stainless Steel |

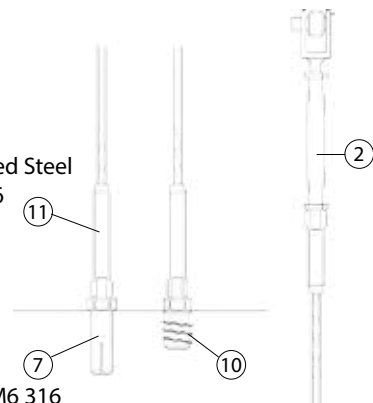

Sec. : Securo
Date: Nov 2018

Securo® - Channel Guide 75 & 110



Securo® Channel Guide 75, Securo® Channel Guide 110, Specifications

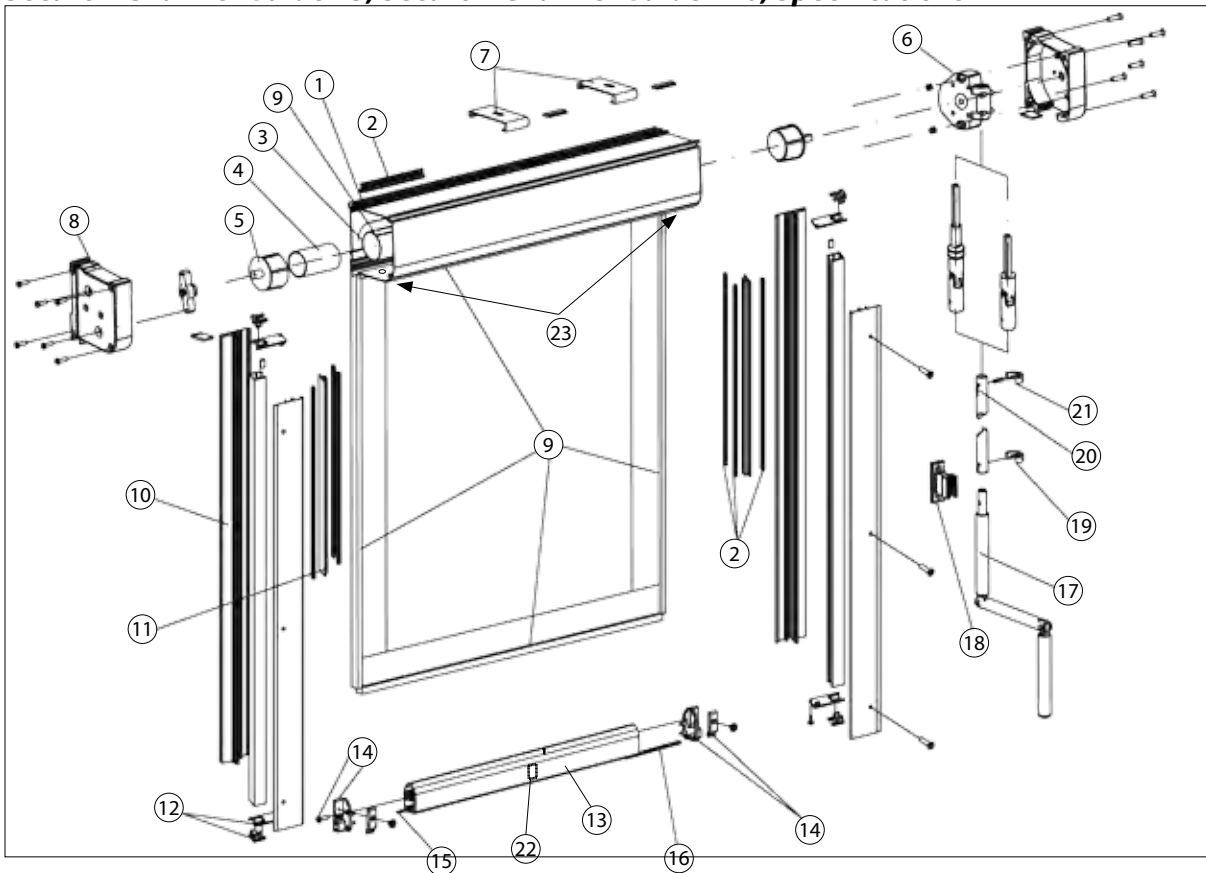

Key Numbers

1. Aluminium Head Box
Colours available: Gun Metal, Perla, White, Matt Black
2. Lip Seal
3. Aluminium Roller Tube Ø 63mm with Securo® Locking Groove, or
Ø70mm Steel Tube (steel tube for motorised blinds only)
4. Aluminium Roller Tube Ø 40mm
5. Round Hub Pivot Ø 10mm
6. Gear 5/5 Ratio with standard Magnetic Cardan Joint
7. Zinc Plated Wall Ceiling Fixing Bracket
8. End Caps Nylon - Colours available: Black, White
9. Securo® Locking Spline (Head Rail, Channel Guides, Bottom Rail)
10. Aluminium Channel Guides (3 Profiles)
Colours available: Gun Metal, Perla, White, Matt Black
11. Channel Guides PVC
12. Channel Guide Plastic End Caps
13. Bottom Rail Aluminium
Colours available: Gun Metal, Perla, White, Matt Black
14. Bottom Rail Plastic End Caps
15. Galvanised Iron Plate
16. Soft Touch - Polybond Woolpile
17. Crank Handle
18. Fixed Crank Handle Holder
19. Ring
20. Aluminium Roller Tube Ø 13mm
21. Ring with Pin
22. Stabilising Bolt (optional) Stainless Steel
23. Drainage holes (7mm Dia)

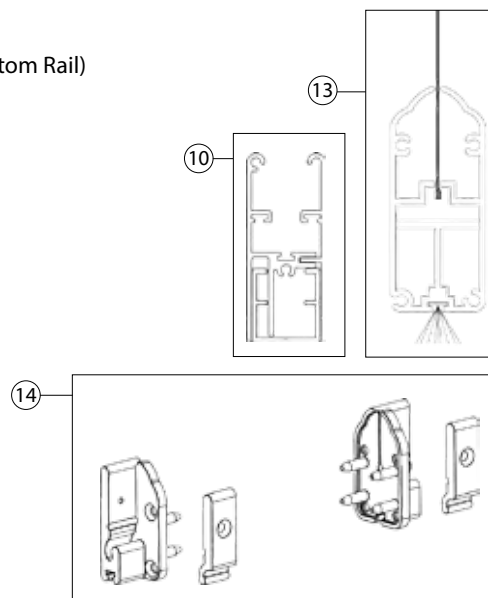

SPECIFICATIONS

Sec. : Securo
Date : Dec 2020

Securo® Channel Guide 75 & 110 Motorisation Specifications

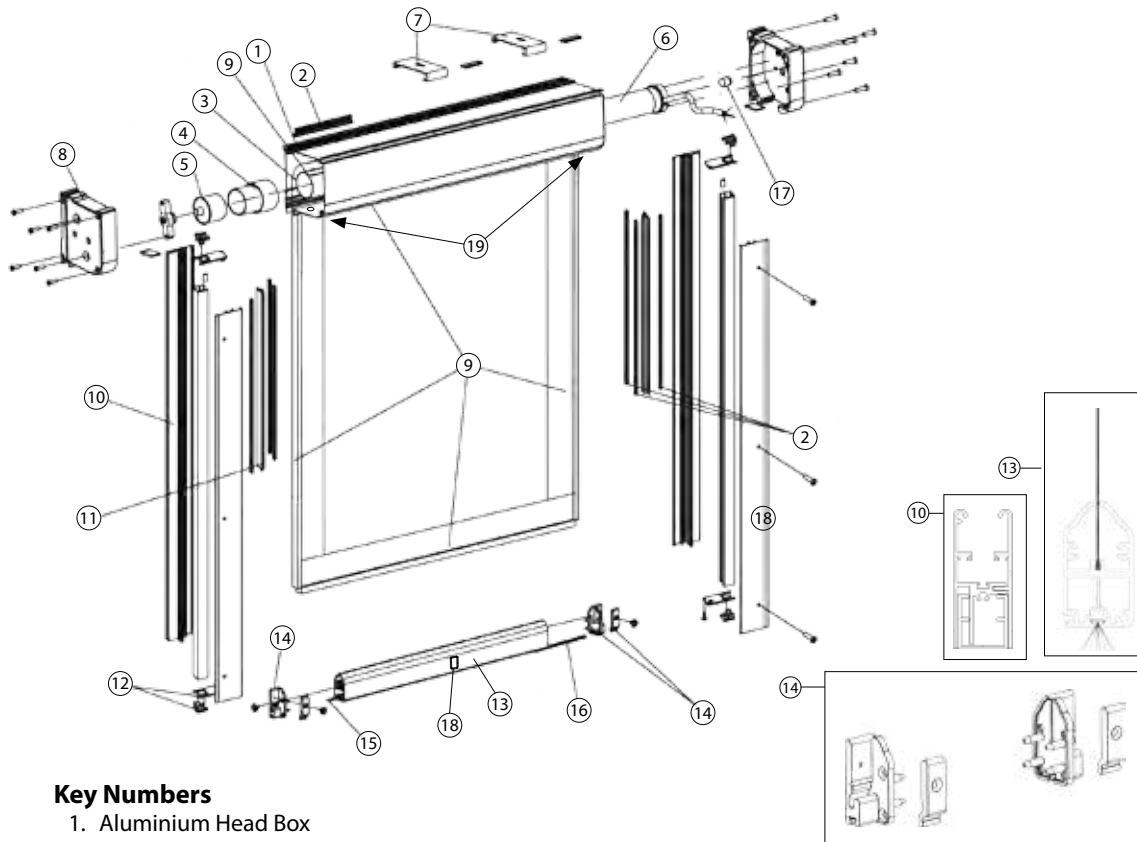

Key Numbers

1. Aluminium Head Box
110 x 138 & 75 x 75 Motorisation
Colours available: Gun Metal, Perla, White, Matt Black
2. Lip Seal
3. Aluminium Roller Tube Ø 53mm with Securo® Locking Groove, or Ø70mm Steel Tube
4. Aluminium Roller Tube Ø 40mm for electric 220V Somfy Motor
5. Round Hub Pivot Ø 10mm
6. Somfy Motor 220V
7. Zinc Plated Wall Ceiling Fixing Bracket
8. End Caps Nylon - Colours available: Black, White
9. Securo® Locking Spline (Head Rail, Channel Guides, Bottom Rail)
10. Aluminium Channel Guides (3 Profiles)
Colours available: Gun Metal, Perla, White, Matt Black
11. Channel Guides PVC
12. Channel Guide Plastic End Caps
13. Bottom Rail Aluminium
Colours available: Gun Metal, Perla, White, Matt Black
14. Bottom Rail Plastic End Caps
15. Galvanised Iron Plate
16. Soft Touch - Polybond Woolpile
17. Pivot for Motor
18. Stabilising Bolt (optional) Stainless Steel
19. Drainage holes (7mm Dia)

Motorisation option - Securo® 75-110 Channel Guide/Wire Guide

Motor Selection		<6m ²	>6m ²
Securo 75-110	RTS	Maestria 6/17	Maestria 10/17
	WT	Ariane 6/17	Jet 10/117

KEY:

WT = Mechanical switch hardwired to the motor.

RTS = Remote control (handheld or wallmounted)

Maximum Width: 4.6m, Maximum Drop: 3.0m (subject to fabric choice)

Performances	Maestria 6/17	Maestria 10/17	Ariane 6/17
Torque	6 Nm	10 Nm	6 Nm
Nominal Voltage	230v	230v	230v
Rated Current	0.45 A	0.5 A	0.4 A
Rated Power	105W	120W	90W
Speed	17 RPM	17 RPM	17 RPM
Thermal Protection	4 Min	4 Min	4 Min
Radio Frequency	433.42	433.42	-
Sound Level (DB)			46
Cable Length	3000mm	3000mm	2500mm
IP Rating	IP 44	IP 44	IP 44
Insulation Class	I	I	I

Sunis Wirefree RTS Sun Sensor



Eolis RTS Wind Sensor



Soliris RTS- Sun & Wind Sensor



Sec. : Securo
Date: Jun 2020

Somfy Sensors

Weather Sensors can be used for automatic control. These include wind and sun sensors. Wind sensors will retract your Securo® if wind speeds exceed 50 km/h. The sun sensor works on light levels and can be programmed to a specific light level.

Securo® Wire Guide 110, 75 Crank Handle

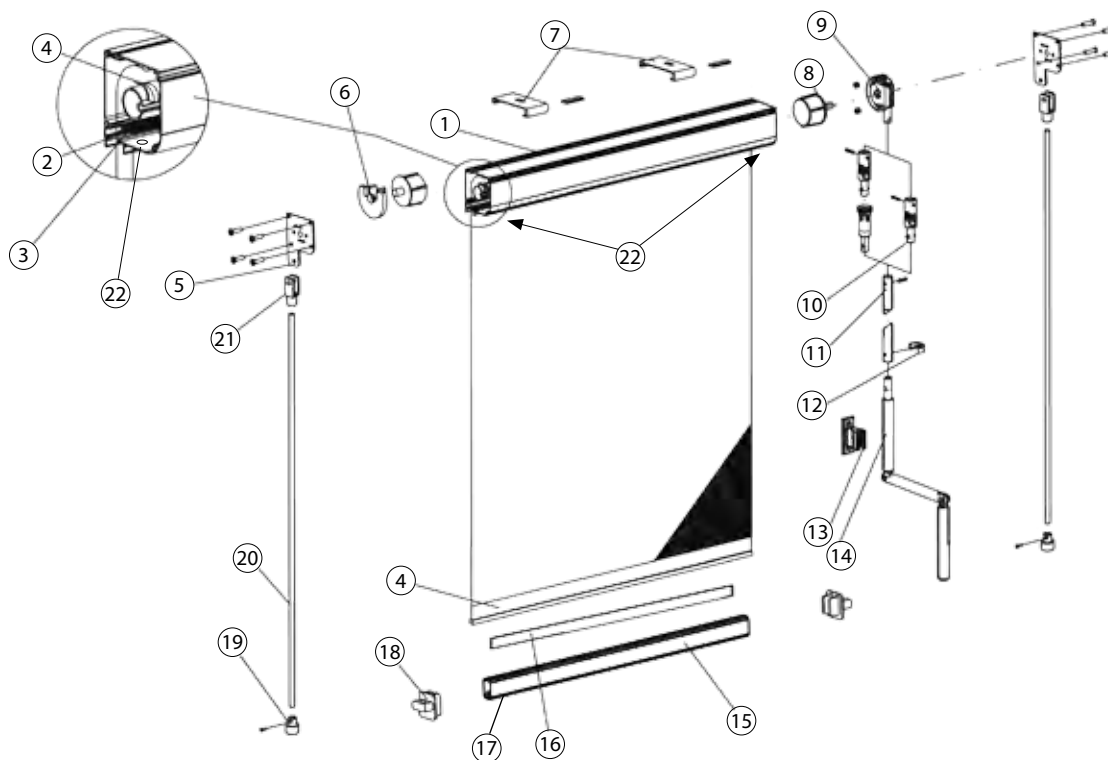

Key Numbers

1. Aluminium Head Box
Colours available: Gun Metal, Perla, White, Matt Black
2. Lip Seal
3. Aluminium Roller Tube Ø 53mm with Securo® Locking Groove and inner Aluminium Roller Tube Ø 40mm, or or Ø70mm Steel Tube (steel tube for motorised blinds only)
4. Zip
5. End Cap Powder Coated over Galvanised Steel
6. Nylon Support
7. Zinc Plated Wall Ceiling Fixing Bracket
8. Hub Pivot Ø 10mm
9. Gear 5/5 Ratio with standard Magnetic Cardan Joint
10. Nickel Brass Cardan Joint
11. Aluminium Crank Handle Tube Ø 10mm
12. Ring with Pin
13. Fixed Crank Handle Holder - Colours available: Black, White
14. Crank Handle - Colours available: Black, White
15. Bottom Rail Aluminium
Colours available: Gun Metal, Perla, White, Matt Black
16. Galvanised Iron Plate
17. Soft Touch - Polybond Woolpile
18. Bottom Rail Plastic End Caps (Colours available: Black, White), with Stainless Steel Eye Bolt
19. Stainless Steel Swage Stud with either;
 - Counter Sunk Socket Screw for Wood Fixing
 - Drop in Anchor for Concrete Fixing
20. 3mm Stainless Steel Wire
21. Stainless Steel Fork Swage
22. Drainage holes (7mm Dia)

Securo® Max Channel Guide

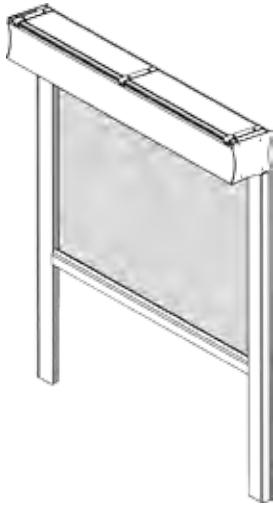

Securo®Max Channel Guide is a revolutionary new addition to the market. Italian designed, **Securo®Max** Channel Guide is the solution for extra large exterior roller blinds.

Securo®Max Channel Guide when motorised, can be linked to a building management system, remote controlled and/or with wall switches. Window Treatments is an authorised Somfy Automation Specialist. For further information on the type of motors, switches and power requirements, please contact motorisation@window-treatments.co.nz

- Application** : Exterior/Interior
- Maximum Size** : 10m wide x 3.0m drop
- Operation** : Motorised
Securo® Max can be linked to a building management system, remote controlled and/or with wall switches with optional light and wind sensors



- Fixing** : Top or Face Fix
- Material Type** : Techno X – durable and tough synthetic FR fabric made of PVC coated polyester designed for outdoor use
- Head Box** : Fully enclosed 2 piece cassette Aluminium head box protecting the roller tube and motor
 Roller Tube with Securo® Locking Groove
 Lip Seal
 Innovative PVC Cradle for supporting the roller tube

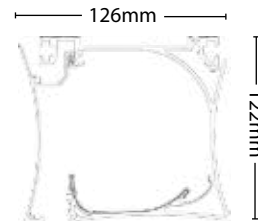

Adjustable Galvanised Steel End Caps and PVC Cradle
 One of the key features of Securo®Max is that it can be manufactured up to 10m wide. This is made possible due to the vertical slide movement of the adjustable galvanised steel end caps. This end cap feature distributes the weight of the Techno X fabric evenly over the aluminium roller tubes. This feature is also enhanced by the innovative PVC cradle that supports the Techno X fabric and tube over the entire width of the blind.

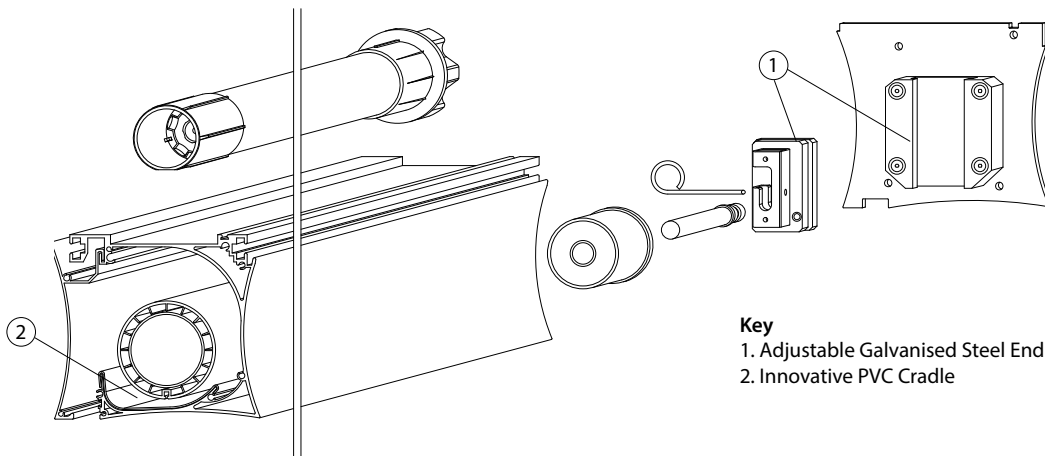

- Key**
- 1. Adjustable Galvanised Steel End Cap
 - 2. Innovative PVC Cradle

Securo[®] Max - Channel Guide



Tube : Aluminium
 Outer Tube Ø63mm
 Inner Motor Tube Ø50mm
 Roller Tube with Securo[®] Locking Groove

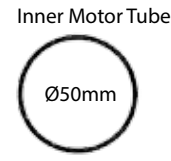
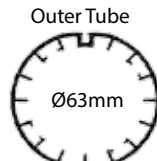

Channel Guides : Aluminium
 4 pieces on each side
 Channel Guide with Securo[®] Locking Groove
 Lip Seal
 Side Fix 25mm x 63mm
 Face Fix 33mm x 63mm

Outer Tube

Inner Motor Tube

Side Fix

or

Face Fix

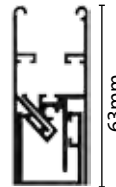

Bottom Rail : Aluminium
 Bottom Rail with Securo[®] Locking Groove
 Lip Seal
 Soft Touch

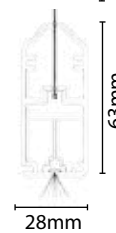

Fixing Options : Face Fix

Top Fix

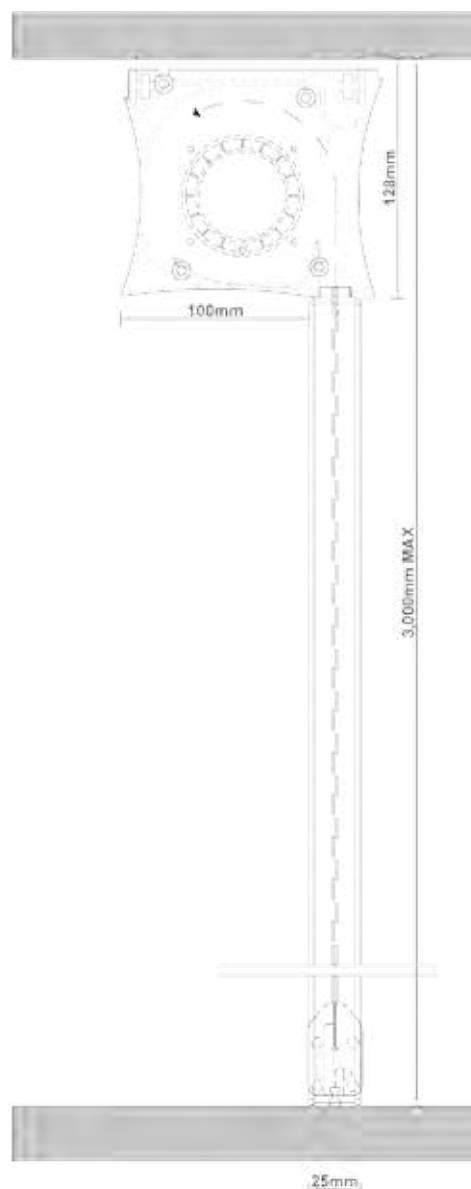
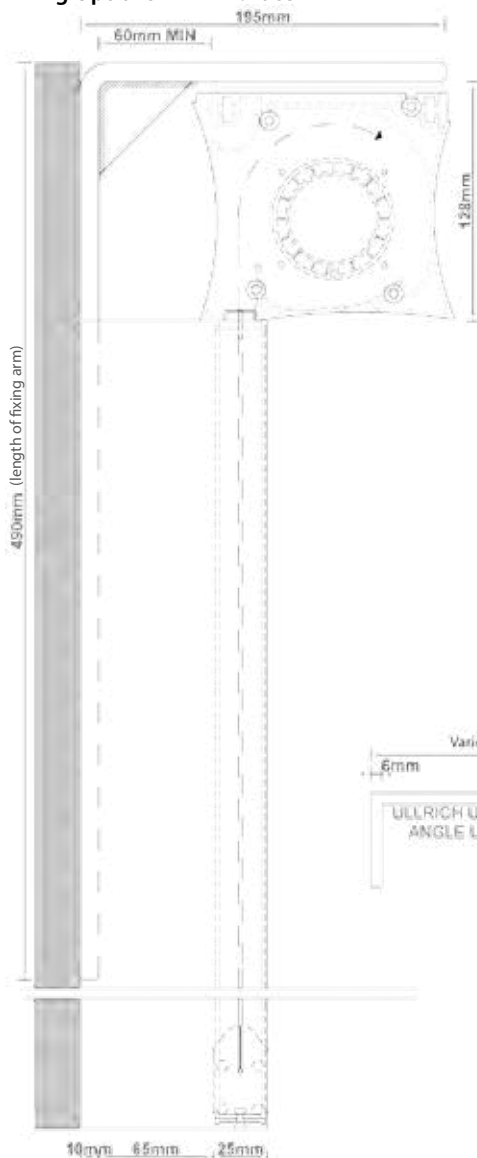

SPECIFICATIONS

Sec. : Securo
 Date : Nov 2018

Securo® Max Channel Guide Specifications

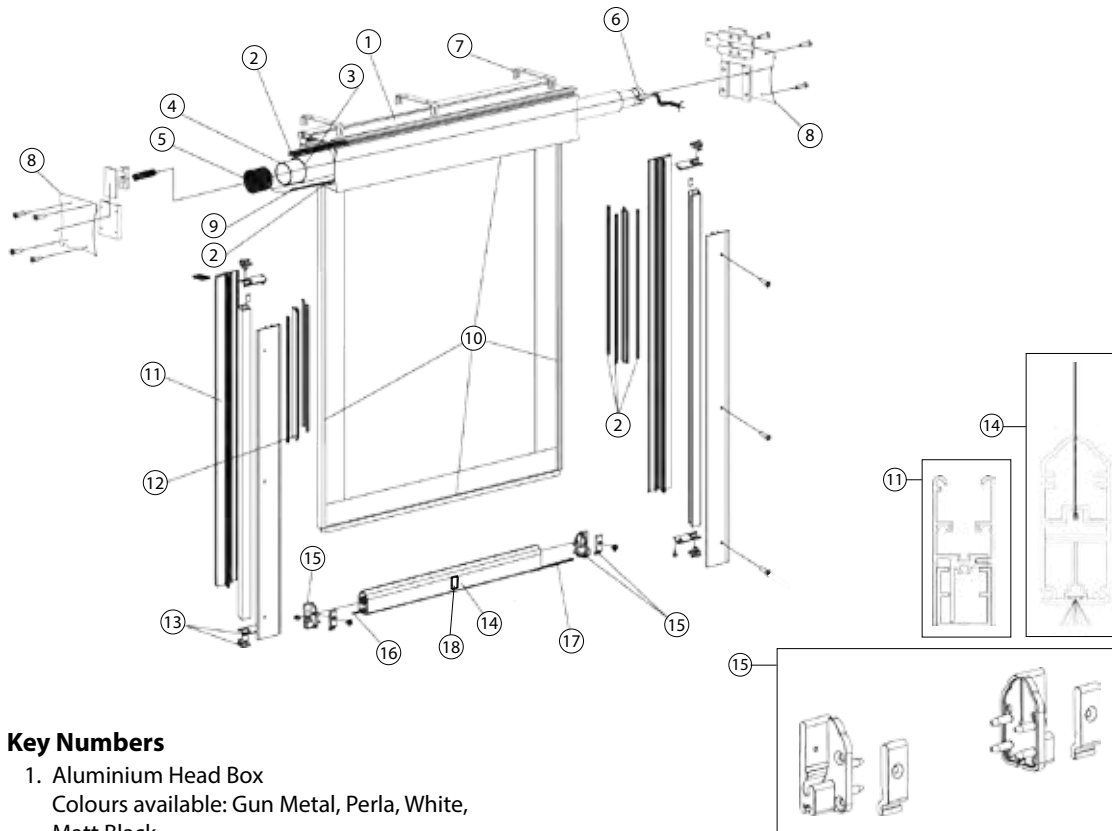

Key Numbers

1. Aluminium Head Box
Colours available: Gun Metal, Perla, White, Matt Black
2. Lip Seal
3. Aluminium Roller Tube Ø 63mm with Securo® Locking Groove
4. Aluminium Roller Tube Ø 50mm for electric 220 V Somfy Motor
5. Round Hub Pivot Ø10mm
6. Somfy Motor 220 V
7. Zinc Plated Wall Ceiling Fixing Bracket
8. Adjustable Galvanised Steel End Caps
9. PVC Cradle
10. Securo® Locking Groove (Head Rail, Channel Guides, Bottom Rail)
11. Aluminium Channel Guides (3 Profiles)
Colours available: Gun Metal, Perla, White, Matt Black
12. Channel Guides PVC
13. Channel Guide Plastic End Caps
14. Bottom Rail Aluminium
Colours available: Gun Metal, Perla, White, Matt Black
15. Bottom Rail Plastic End Caps
16. Galvanised Iron Plate
17. Soft Touch - Polybond Woolpile
18. Stabilising Bolt (optional) Stainless Steel

Motorisation - Securo Max Channel Guide/Wire Guide

Motor Selection		<10m ²	>10m ²
Securo Max	RTS	Maestria 10/17	Maestria 25/17
	WT	Jet 10/17	Gemini 25/17

KEY:

WT = Mechanical switch hardwired to the motor.
 RTS = Remote control (handheld or wallmounted)
 Maximum Width: 10m, Maximum Drop: 3.0m

Performances	Maestria 10/17	Jet 10/17	Maestria 25/17	Gemini 25/17
Torque	10 Nm	10 Nm	25 Nm	25 Nm
Nominal Voltage	230v	230v	230v	230v
Rated Current	0.5 A	0.5 A	0.8 A	0.8 A
Rated Power	120W	120W	170W	170W
Speed	17 RPM	17 RPM	17 RPM	17 RPM
Thermal Protection	4 Min	4 Min	4 Min	4 Min
Radio Frequency	433.42	433.42	433.42	433.42
Sound Level (DB)		47		57
Cable Length	3000mm	2500mm	3000mm	2500mm
IP Rating	IP 44	IP 44	IP 44	IP 44
Insulation Class	I	I	I	I

Sunis Wirefree
RTS Sun Sensor



Eolis RTS Wind Sensor



Soliris RTS- Sun & Wind
Sensor



Sec. : Securo
Date: Dec 2020

Somfy Sensors

Weather Sensors can be used for automatic control. These include wind and sun sensors. Wind sensors will retract your awning if wind speeds exceed 35 km/h. The sun sensor works on light levels and can be programmed to a specific light level.

Securo® Max - Wire Guide



Securo® Max Wire Guide

Securo®Max wire guides are substituted for the Securo® channel guides. Wire guides are used where there isn't any end fixing to attach the channel guides to. The wire guides incorporate stainless steel wire, eye bolts, jaw/swage pipe turn-buckles, swage studs and drop in anchors.

The maximum size is 10m wide x 3.0m drop. Securo®Max Wire Guide when motorised, can be linked to a building management system, remote controlled and/or with wall switches and with optional light and wind sensors.

Window Treatments has a variety of fabrics for interior/exterior applications. For exterior applications, we recommend Techno X which is a durable and tough synthetic FR fabrics made of PVC coated polyester designed for outdoor use. For interior applications, the Securo®Max Wire Guide System can be used in conjunction with a variety of Sunscreen fabrics.

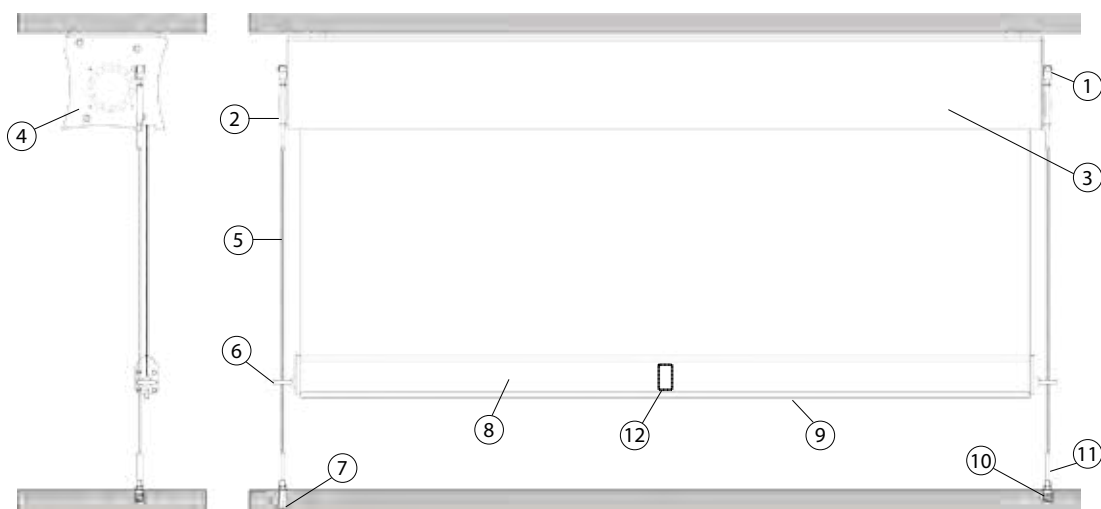

Side View - Head Box/Jaw/Swage Pipe

Front View - Jaw/Swage Pipe

Front View - Eye Bolt/Wire

Side View Bottom Rail

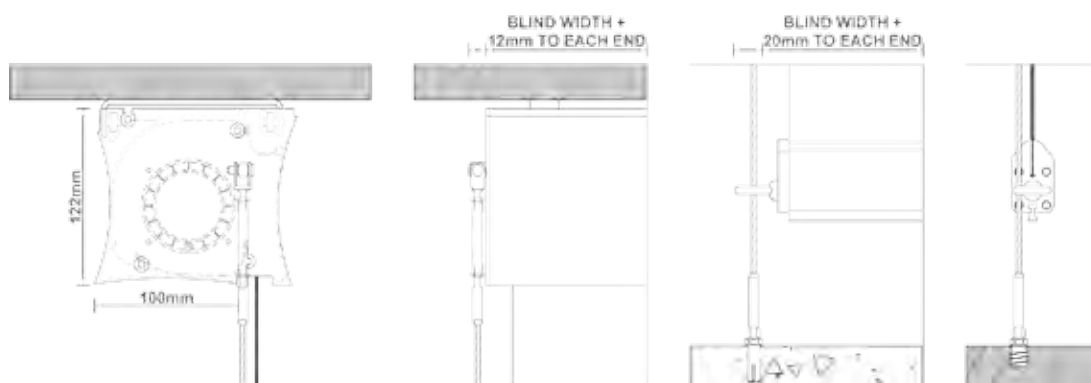

Key Numbers

- | | |
|---|---------------------------------------|
| 1. Eyelet | : Stainless Steel 316 |
| 2. Jaw/Swage Pipe Turnbuckle | : Stainless Steel S3121P M6/3.0 |
| 3. Head Box | : Aluminium |
| 4. End Cap | : Powder Coated over Galvanised Steel |
| 5. 3mm Stainless Steel Cable Wire | : Stainless Steel 7 x 19 ASIST316 |
| 6. Eye Bolt | : Stainless Steel 316 |
| 7. Drop in Anchor (Concrete Fixing) | : Stainless Steel 316 |
| 8. Bottom Rail | : Aluminium |
| 9. Soft Touch | : Polybond Woolpile |
| 10. Counter Sunk Socket Screw (wood fixing) | : Stainless Steel 316 |
| 11. Swage Stud | : Stainless Steel S7801 3mm x M6 316 |
| 12. Stabilising Bolt (optional) | : Stainless Steel |

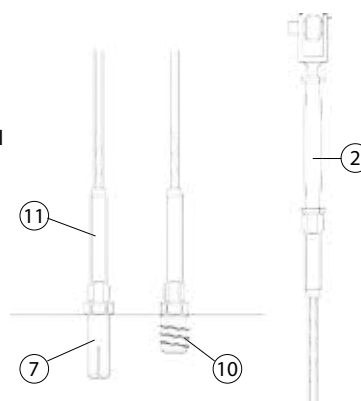

SPECIFICATIONS

Sec. : Securo
Date: Jul 2019

Securo® - Side Roll

Securo® Side Roll

Securo® Side Roll finally resolves the problem of achieving insect control whilst providing easy access through sliding doors and French doors. The solution utilises the Securo® fabric locking system with a spring loaded cassette/Head box roller blind but instead of rolling from the top to the bottom, it rolls from side to side.

The system has the added benefit of an "easy to use" brake so that the blind can be opened to any desired position. The brake handle is positioned on the sliding stile at normal door handle height.

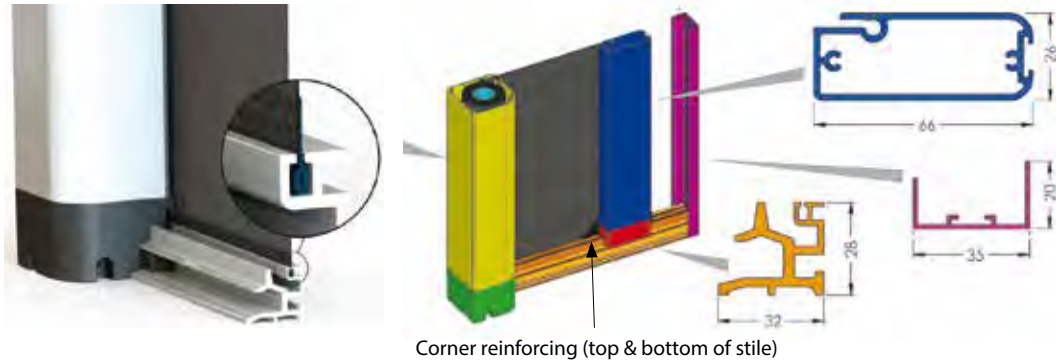

Application	: Interior and Exterior
Maximum Size	: Single screen - 4m W x 2.7m H or Double screen - 8m W x 2.7m H
Operation	: Sliding side to side with brake
Fixing	: Face Fix (recommended) or Top Fix (where Face Fix is not possible)
Material Type	: Interior - Phiferglass Pool & Patio Mesh Exterior - Phiferglass Pool & Patio Mesh
Housing	: Aluminium (60mm x 60mm, 70mm x 70mm or 80mm x 80mm). Fully enclosed one piece housing protecting the roller tube and fabric.

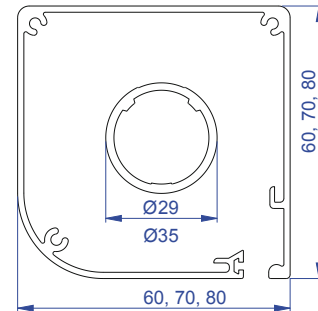

Tube	: Aluminium, 29mm and 35mm dia
Track	: (Top & Bottom) Aluminium 32mm x 28mm

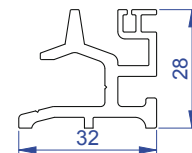

Receiver	: 35mm x 20mm
-----------------	---------------

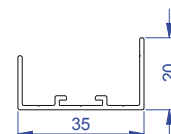

Stile	: 66mm x 26mm
--------------	---------------

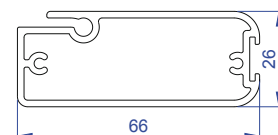

Securo® Side Roll - Installation Options

Recess Track Option

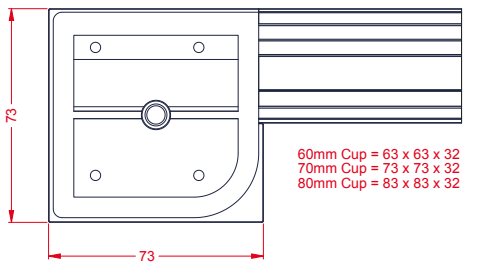
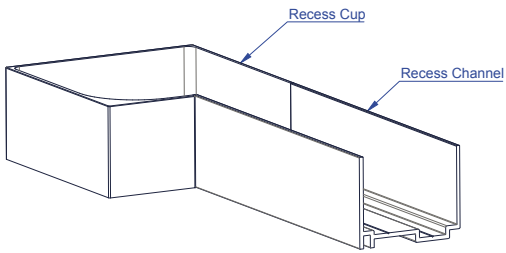
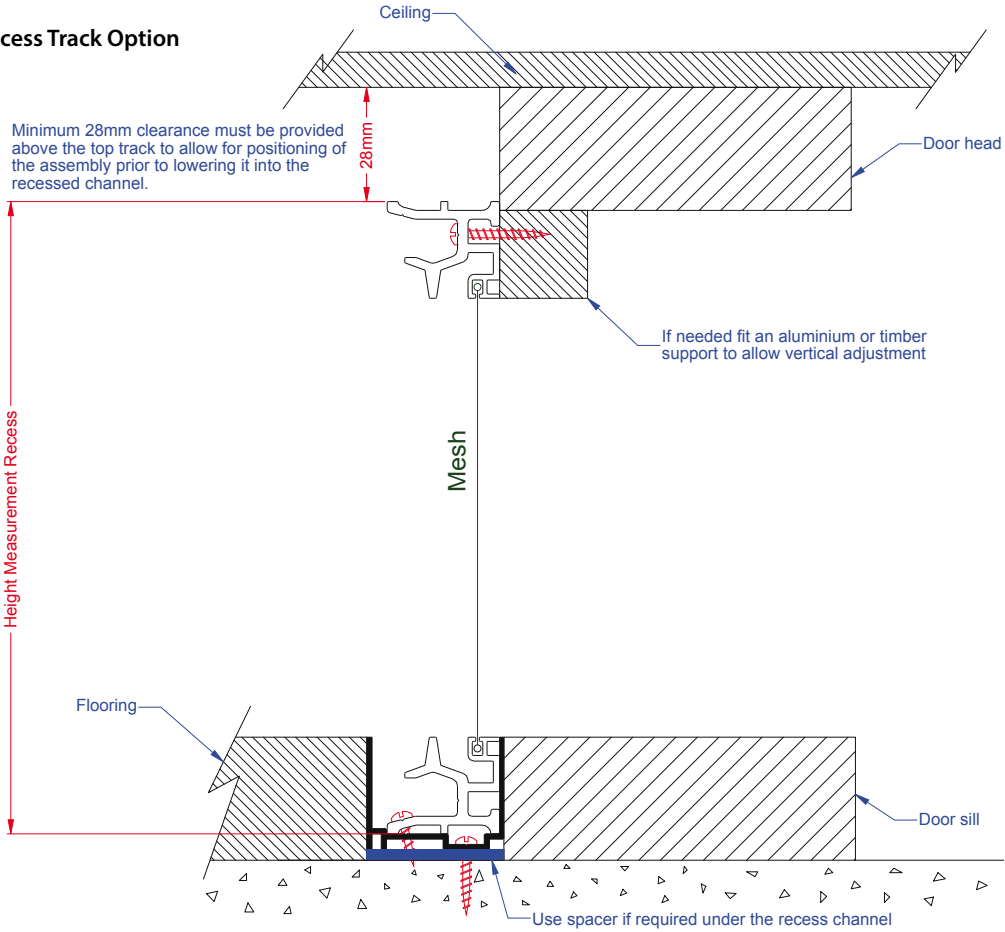

Recess channel & cup assembly may be fitted first to allow flooring to be completed. The screen unit may then be fitted at a later stage near project completion.

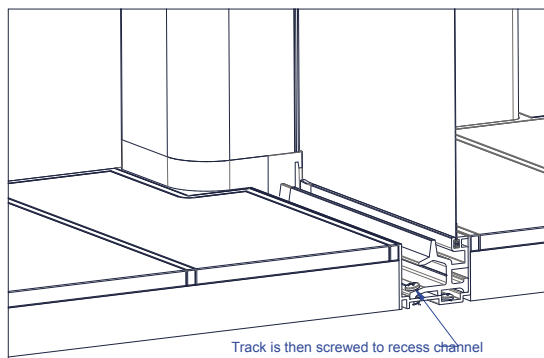
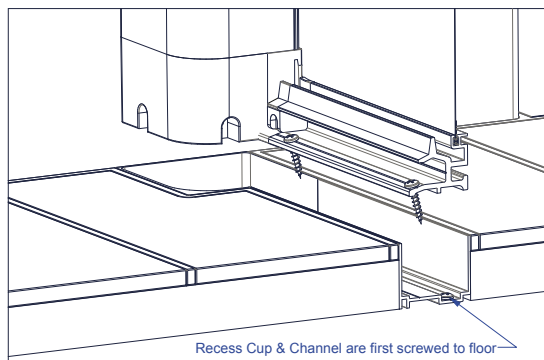

SPECIFICATIONS

Sec. : Securo
Date : Aug 2016

Options for Face Fix and Top Fix (inside door/window jamb)

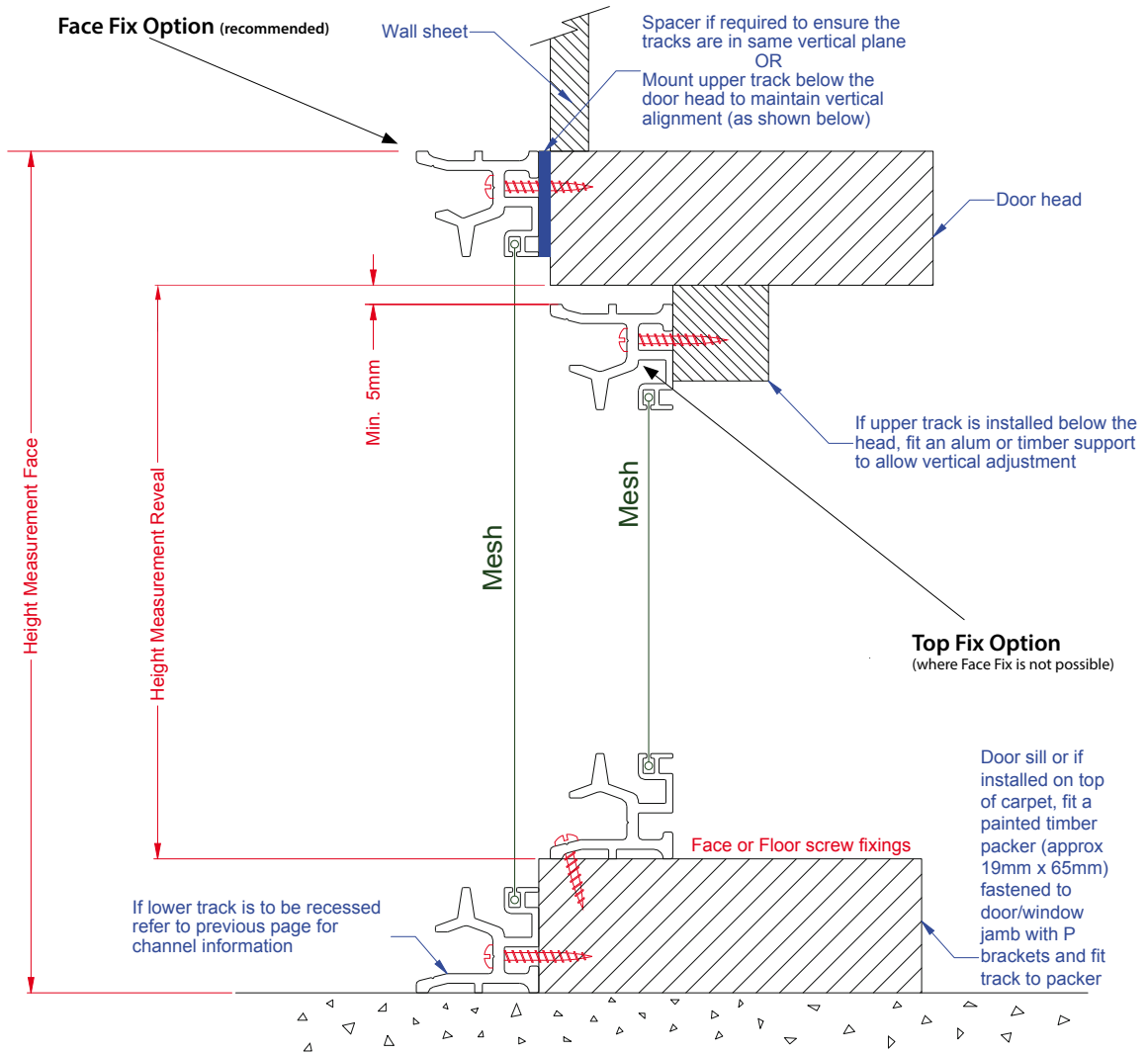

Double Screen

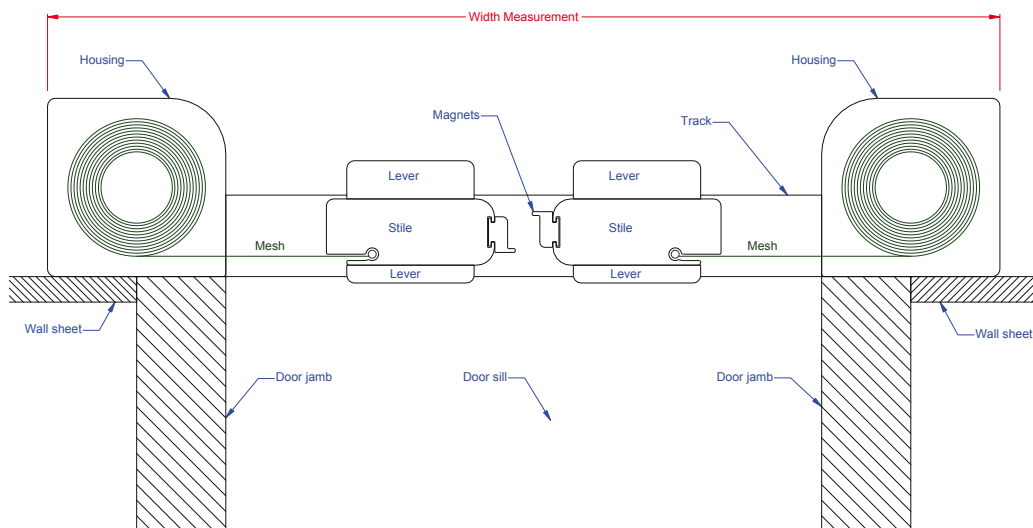

Securo® - Side Roll



Exterior Sliding Stacking Doors

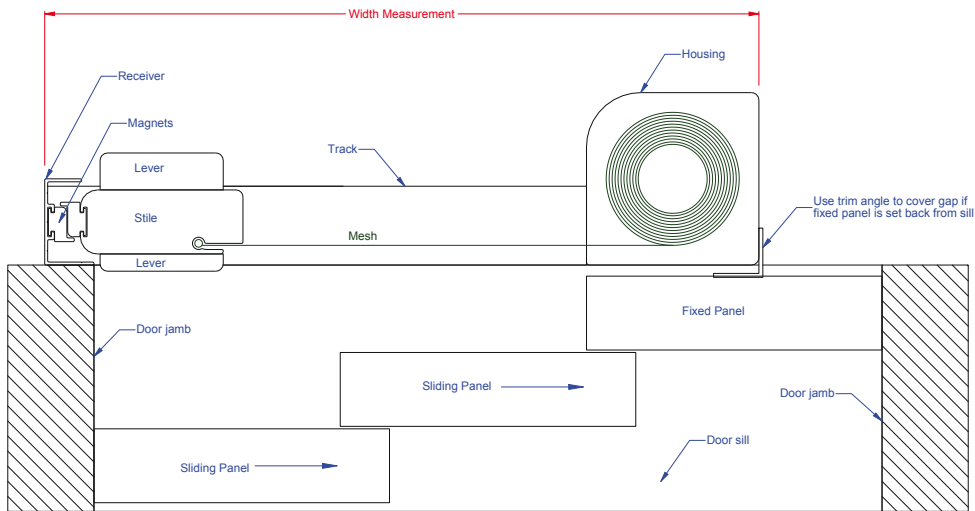

Exterior Bi-Fold Doors

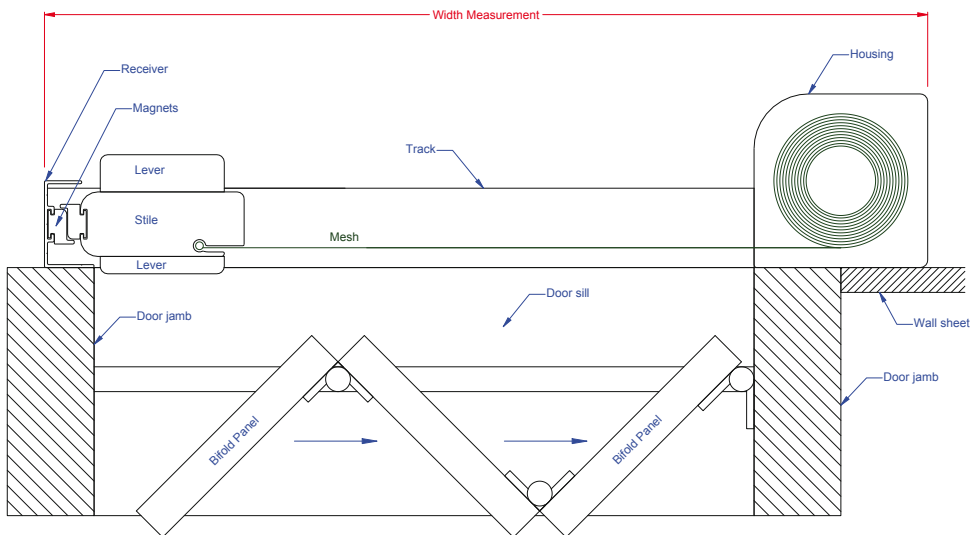

Internal Corner

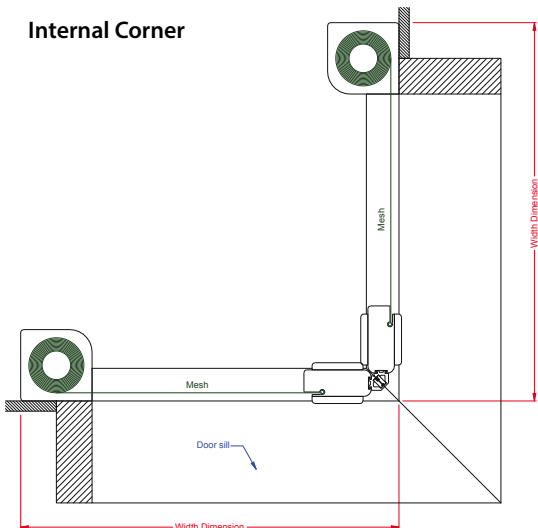

Exterior Corner

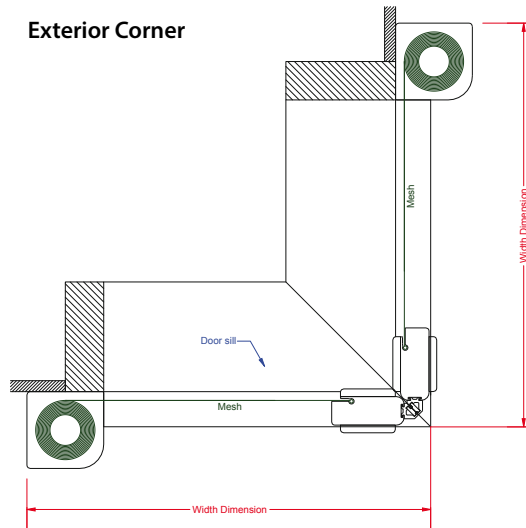

SPECIFICATIONS

Sec. : Securo
Date: Aug 2016

Securo® Side Roll

Size Limits		
Housing	Single	Double
60mm Phiferglass Pool & Patio Mesh	Up to 1600mm width x 2700mm drop	Up to 3200mm width x 2700mm drop
70mm Phiferglass Pool & Patio Mesh	Up to 2800mm width x 2700mm drop	Up to 5600mm width x 2700mm drop
80mm Phiferglass Pool & Patio Mesh	Up to 4000mm width x 2700mm drop	Up to 8000mm width x 2700mm drop

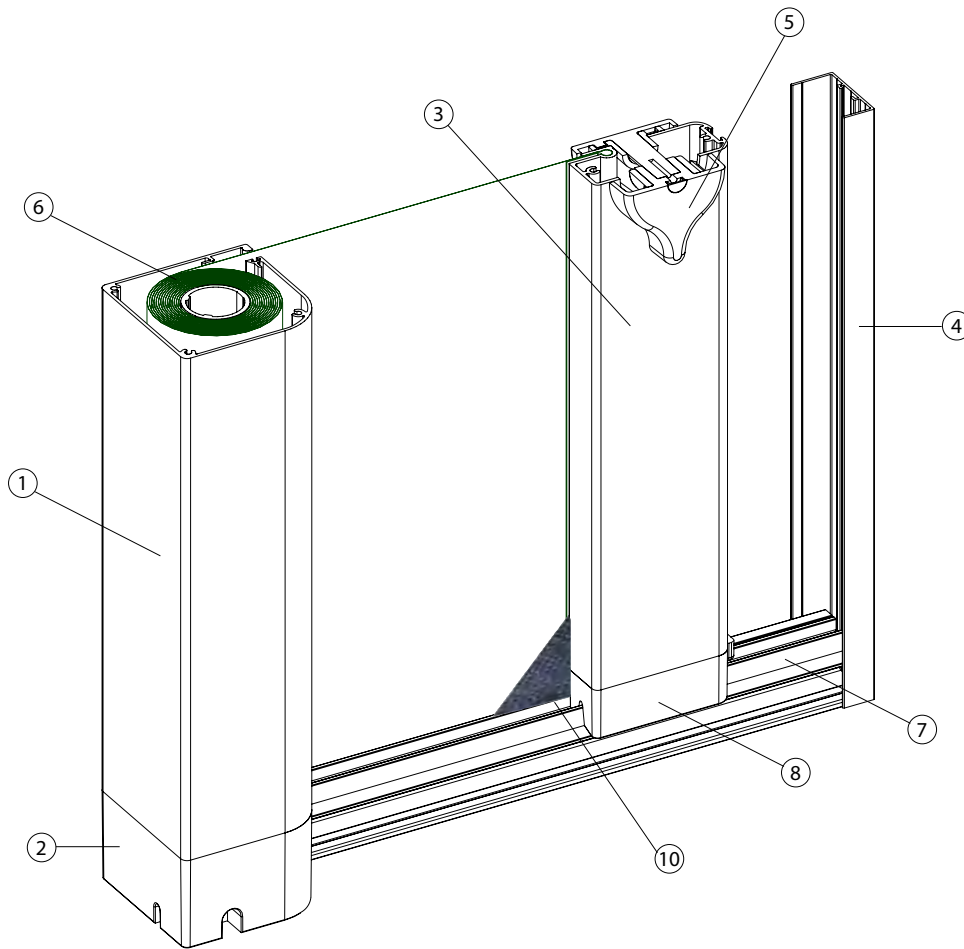

Key Numbers

- | | |
|---|-------------|
| 1. Housing | : Aluminium |
| 2. End Cap | : PVC |
| 3. Stile | : Aluminium |
| 4. Receiver | : PVC |
| 5. Brake Handle | : PVC |
| 6. Tube | : Aluminium |
| 7. Track | : Aluminium |
| 8. Stile Cap and Brake | : PVC |
| 9. Magnet | : Magnet |
| 10. Corner Reinforcing on Stile side (top & bottom) | |

Note:

- Colours available for Key numbers (1, 3, 4, 7) are : Gun Metal, Perla, White, Matt Black
- Colours available for Key numbers (2, 5, 8) are : Black, White

Fabric Overview



The Window Treatments range of fabrics offers endless opportunities when used in commercial or domestic internal applications. We supply various fabrics which comprise of intelligent energy saving screen fabrics, ecologically friendly, fire retardant, PVC free, mould and mildew resistant, light-filtering to block-out fabrics. For all fabrics, specifications are available on request.

Sunscreen:

The Techno Screen range is very cost effective and works well in both commercial and domestic situations. Techno Screen is dimensionally stable and comes in a wide range of colours in both 5% and 3% openness. Both Screen ranges are fire retardant.

Light-filtering Fabrics:

Our light filtering fabrics provide more privacy than screen fabrics but still allow you to enjoy ambient light. The lighter the fabric colour the more ambient light you will achieve in the room. 100% polyester and acrylic coated, the Filtra range is also PVC Free.

Block-out Fabrics:

We carry an extensive range of block-out fabrics, some with a textured finish and others with foam or white flocked acrylic backing. These fabrics are ideally suited for computer rooms, offices, home theatre and bedrooms as they prevent glare and provide complete block-out when required. Most of our block-out fabrics are PVC free and all are resistant to mould and fungi, making block-out blinds ideal for installations in areas of high humidity and moisture.

Exterior Fabric:

When using **Securo® Wire Guide** for exterior applications, we recommend Techno X which is a durable and tough woven vinyl coated polyester core yarn that is formulated to withstand solar damage.



Fabric Types:

Fabric Type	Maximum Width	Maximum Drop without Weld	Maximum Drop with Weld	Internal	External
Securo® Pull Down Blind					
Phiferglass Pool & Patio Mesh	2.40m	2.0m		Yes	Yes
Soltis 88 Screen	2.10m	2.0m		Yes	Yes
Soltis 99 Screen	2.10m	2.0m		Yes	No
Icon FR Blockout, Duo Block	2.10m	2.0m		Yes	No
Securo® Channel Guide 75					
Techno X	3.9m	1.3m		Yes	Yes
Block-out	3.9m	1.3m		Yes	No
Enviroshade & Filtra	3.9m	1.3m		Yes	No
*Clear PVC	3.9m	1.3m		Yes	Yes
Securo® Channel Guide 110					
Techno X	4.6m	3.0m		Yes	Yes
Block-out	4.6m	2.7m		Yes	No
Enviroshade & Filtra	4.6m	2.4m	3.0m	Yes	No
Clear PVC	4.6m	1.37m	2.7m	Yes	Yes
Securo® Max					
Techno X	10m	3.0m		Yes	Yes
**Techno Screen	10m	3.0m		Yes	No
Securo® Side Roll					
Phiferglass Pool & Patio Mesh	4.0m	2.7m		Yes	Yes

* PVC is available but not recommended due to the drop limitations of the 75mm head box

**For Securo® Max blinds exceeding 3000mm wide Techno Screen is railroaded and a disclaimer is required.



Securo® - Fabric

SPECIFICATIONS

Techno X Solar Screen

Solar Screen Fabric 3% Openness

When using **Securo® Wire Guide** or **Securo® Max Wire Guide** for exterior/interior applications we recommend **Techno X Solar Screen**. This fabric is a tough woven durable polyester yarn that is formulated to reduce heat transfer through windows before it reaches the glass. This fabric also reduces the glare and harmful rays from the sun. Flame resistant and fade resistant, **Techno X Solar Screen** is a durable alternative for insect screen. Excellent for daytime privacy without blocking the view, this versatile fabric will endure years of outdoor use. **Techno X Solar Screen** blocks up to 95% of the sun's rays.

Techno X Solar Screen	
Composition	30% Polyester, 70% PVC
WEIGHT g/m ²	550
Thickness mm	0.70
Openness Factor	3%
Light Fastness & Standard	Grade 8, ISO105 B02-1994
Flammability (FR) / Ignitability Index & Standard	BS5867 Part 2 Type B NFPA 701:2015 TM #2

Techno X Solar Screen				
Colour:	Tv	Ts	Rs	As
Black	11%	7%	3%	90%
Slate	12%	8%	9%	83%
Stone	15%	13%	43%	44%



Techno X Fabric - Black, also available in Slate & Stone



Insect Screen

Composition :

Phiferglass Pool & Patio Mesh - A woven fibre glass coated with PVC.

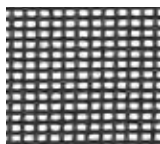

Physical Properties	Warp	Fill	Test Method
TENSILE STRENGTH			
A. Cust strip method (lb)	160	128	ASTM D 5035
B. Grab Method (lb)	165	128	ASTM D 5034
TEARING STRENGTH			
Trapezoid Method (lb)	16	15	ASTM D 5587
YARN SLIPPAGE (lb)	46	41	ASTM D 4912
STIFFNESS (mg)	258	210	ASTM D 3656
MESH WEIGHT (oz/sq yd)		4.4	ASTM D 3776
FABRIC THICKNESS (inch)		0.016	ASTM D 1777
BOND STRENGTH (lb)		36	CS 248-64
OPENNESS/TRANSMITTANCE (%)		56.4	I7
BLOCKING		Scale 1	FS L-S-125B
COLOURFASTNESS to 1200hrs Colour Change According to AATCC Gray Scale		All colours 4 min	TMS-TM-003
Mullen Bursting Strength (psi)		196	FS L-S-125B

Clear PVC

Composition

PVC Super Clear sheet laminated 0.75mm

Thickness

Physical Properties		1.0mm x 48PHR	0.8mm x 46PHR	Test Method
TENSILE STRENGTH (kg/cm ²)	MD	278.1	253.8	ASTM D-882
	CD	230	223.1	
ELONGATION (%)	MD	350	338	ASTM D-882
	CD	387	385	
TEAR STRENGTH (kg/mm)	MD	8.2	8.5	ASTM D-1004
	CD	8.7	8.0	

Sec. : Fabric
Date: May 2021



Café Blind



SPECIFICATIONS

Sec. : Café Blind
Date : Jun 2021

Café Blind - Overview



SPECIFICATIONS

Product Overview & Applications

The Café Blind has been developed to meet the ever-increasing demand for a strong but simple cost-effective outdoor blind to provide shelter from wind and rain. The café blind is installed with strong bottom rail anchor options and is particularly suited to the hospitality industry such as cafés and outdoor restaurant areas.

Key Features

- Heavy duty exterior Roller Blind
- Fabric: Clear PVC, Techno X screen and Awning fabrics
- Maximum size: Width 4500mm x Drop 3000mm with a maximum square meterage of 12m²
- Tube: 70mm dia Galvanized Steel
- Heavy duty cast aluminium universal face/top mounting brackets (Gun Metal or Perla)
- Heavy duty aluminium bottom rail with Gun Metal or Perla end caps.
- Various component & carabiner options to connect the bottom rail to the ground.
- Option to include a draft strip (approx 200mm drop by the width of the blind) fitted to the underside of the bottom rail. The draft strip covers the component space taken to anchor the bottom rail to the ground fixing points.
- Recommended for winds up to 65km/hr.

The Café Blind carries our standard three-year warranty. This warranty covers repair or to make good any defects in materials or workmanship.

Operation

Manual or motorised operation is available for Café Blinds. The bottom rail anchor components are attached to the ground fixing points after the blind is lowered and conversely released before the blind is raised.

Manual

Café Blinds can be operated by a gear crank drive or by motorisation controls. Crank handle lengths are available in 1m, 1.5m, 1.8m or 2.2m to suit the location requirements for manual operation

Motorisation

Window treatments motorised Café Blinds are surprisingly simple and inexpensive with the Somfy range of 240v motors. Control can be by either wall mounted hard wired switch with the Somfy LT50mm motor or remote control with the Somfy Altus 50mm (RTS) motor. (Refer Motorisation Section)

Fabrics

Café Blinds can be supplied in a wide variety of materials (refer below), all of which provide shelter from wind and rain.

- Clear PVC for unobstructed view with no shading effect when looking from the inside to the outside and outside to inside. PVC skin sides are finished with a 50mm wide reinforcing strip for increased strength and tear resistance.
- Techno X (screen fabric) for shaded view looking from the inside to the outside and slightly obscured view looking from the outside to inside. Techno X skin sides are folded and sewn for increased strength and tear resistance.
- Standard awning fabric for total privacy and light block. Awning skin sides are folded and sewn for increased strength and tear resistance.

Motorisation - Café Blind

Window Treatments NZ Ltd offers a motorized option for Café Blinds through Somfy motorisation. This includes RTS and Wired motors as well as remotes, wall mounted switches and the ability to be linked with a building management system.

Café Blinds use one of four different motors for automation depending on the size of your application

Note:

Somfy automatic Wind and Sun sensors are not suitable for Café Blinds given that the bottom rail is physically anchored to the ground when the blind is in the down position.

Maximum Sizes and Construction

Fabric	Maximum Width	Maximum Drop	Maximum M ²	Horizontal welded joins	Vertical sewn joins
Clear PVC	4500mm (with 2 joins)	3000mm	12m ²	Yes	
Techno X	4500mm (with 1 join)	3000mm	12m ²	Yes	
Standard Awning	4500mm (with 3 joins)	3000mm	12m ²		Yes

Motor Selection		<10m ²	>10m ²
Securo Max	RTS	Maestria 10/17	Maestria 25/17
	WT	Jet 10/17	Gemini 25/17

KEY:
 WT = Mechanical switch hardwired to the motor.
 RTS = Remote control (handheld or wallmounted)
 Maximum Width: 10m
 Maximum Drop: 3.0m

Performances	Maestria 10/17	Jet 10/17	Maestria 25/17	Gemini 25/17
Torque	10 Nm	10 Nm	25 Nm	25 Nm
Nominal Voltage	230v	230v	230v	230v
Rated Current	0.5 A	0.5 A	0.8 A	0.8 A
Rated Power	120W	120W	170W	170W
Speed	17 RPM	17 RPM	17 RPM	17 RPM
Thermal Protection	4 Min	4 Min	4 Min	4 Min
Radio Frequency	433.42	433.42	433.42	433.42
Sound Level (DB)		47		57
Cable Length	3000mm	2500mm	3000mm	2500mm
IP Rating	IP 44	IP 44	IP 44	IP 44
Insulation Class	I	I	I	I

Sec. : Café Blind
Date : Jun 2020

Fixing

Fixing of a Café Blind can be either face or top mount using universal heavy-duty cast aluminium mounting brackets. The mounting brackets are available in both Gun Metal or Perla colours.

After the Café Blind is lowered, the bottom rail is fastened to the ground with either:

- Carabiner and folding eyehook
- Face mounting aluminium anchor or Powder coated Steel anchor

Note: we recommend 1 anchor at each side plus one for every 1.5m of width.

Fabric Gap

On all Café Blinds there is a gap on both sides of approximately 60mm between the outside of the brackets and the edge of the fabric.

Finishes

Powder coated Gun Metal or Perla for:

- Aluminium face/top mounting brackets
- Bottom rails
- Face mounting aluminium anchors & steel anchors

Stainless Steel for:

- Carabiner and folding eyehook

- A. 50mm Reinforcing Strip
- B. Draft Strip
- C. Heavy Duty Aluminium Bottom Rail
- D. Ground Mounting Stainless Steel Carabiner & Folding Eyepad.
- E. 1. Face Mounting Aluminium Anchor Fixing
- E. 2. Face Mounting Powder Coated Steel Anchor Fixing with L Bracket
- F. Galvanised Steel 70mm Dia. Tube
- G. Heavy Duty Aluminium Mounting Bracket

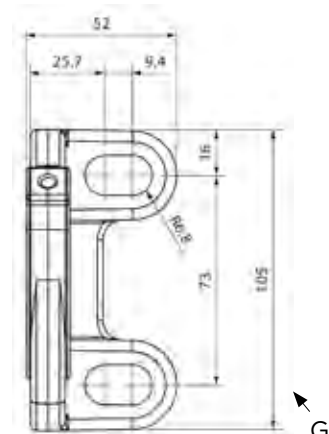
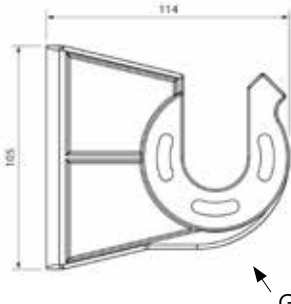
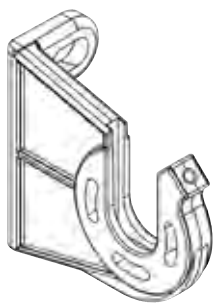
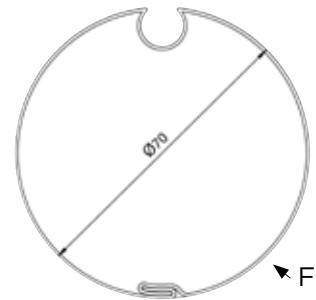
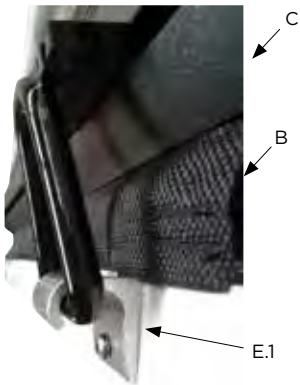
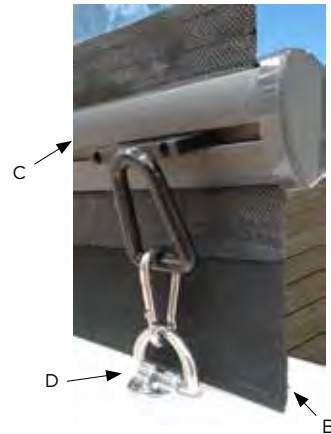



Other



SPECIFICATIONS

Sec. : Other
Date: Sep 2018

Vertical Blinds - Product Overview

SPECIFICATIONS

Product Overview



Our robust vertical blind system features a rust free extruded aluminium powder coated head rail. The head rail is fixed in place using a spring steel nickel plated bracket. A geared control unit and 2-wheeled traveller mechanism supports a specially designed four prong tilt shaft to ensure precision closing. The travellers are UV resistant and incorporate a self-aligning mechanism with limit stops to prevent over-rotation. These 2-wheeled travellers within the aluminium head rail supports fabric louvres of 89mm width. Louvres can be traversed to either or both sides as required and can also be rotated through 180 degrees allowing you to fully control both privacy and the amount of light coming through the window. End caps at either end of the track enclose all working parts. Fabric slats are sewn top and bottom using a 100% UV resistant highly transparent nylon monofilament sewing thread (.011 DIA).

Travellers, controllers, end caps, cords, wands and weights are fully colour coordinated. The head rail comes in various colours. All plastic parts such as travellers, controllers, end caps, slat hangers and control weights are made from prime grade (POM) Polyoxymethylene and the composition of the bottom weights is Calcium Carbonate.

Applications

Being very versatile, vertical blinds offer you complete or partial privacy and caters for either domestic or commercial applications. In a domestic application they are used on the traditional ranch-slider, patio doors, conservatories, living rooms, bedrooms and bay windows. For commercial applications, we carry a wide variety of fabrics suitable for schools, hospitals, restaurants, hotels, to apartments and office buildings and are also ideal for dressing large panels of glass in office complexes. Verticals have the additional benefit of being the ideal solution for irregular windows where a raked blind is required.

Fabrics

A comprehensive range of colours and styles are available to suit any specification including block-out, translucent and sunscreen.



Head Rail

The elegant low profile curved side head rail design measuring just 45mm x 25mm deep gives a compact impression. The extrusion is rust free extruded aluminium powder coated available in various colours.

Fixing

The ceiling side of the track has a specially designed channel to allow for perfect fixing using the snap-in spring steel nickel plated bracket.

The 2-Wheeled Carrier

The benefits of having two wheels over traditional Carriers with no wheels are significant. It allows the operation to be ultra-smooth and very quiet. Apart from the quietness, the smooth operation excels particularly on large windows as there is very little effort required when pulling the louvres to one side. The other significant benefit is that the 2-wheeled travellers are of reduced width allowing for minimal stacking of the blind when in the open position.



Operation: there are two options available

1. Wand control: The aluminium wand with a PVC grip handle is attached to the leading slat carrier. The wand can be twisted to adjust the angle of the louvres to the desired position as well as used to traverse the blind to one side. The wand control is our recommended option due to its child safety feature (no cords) and simple function. Wand colours are available in White, Grey or Black. Louvre size is 89mm. Maximum size: Width 3.2m, Drop 3.5m

2. Cord control: A polyester cord pull to traverse the slats and a beaded chain for rotation of louvres. Both controls can be positioned either on the left or right hand side of blind or at opposite ends. The beaded rotation chain has a stretch resistant nylon core for strength. Various stack options are available. Colours available: white, grey, black. Louvre size is 89mm. Maximum size: Width 4.0m, Drop 3.5m

Controls and Stack Options

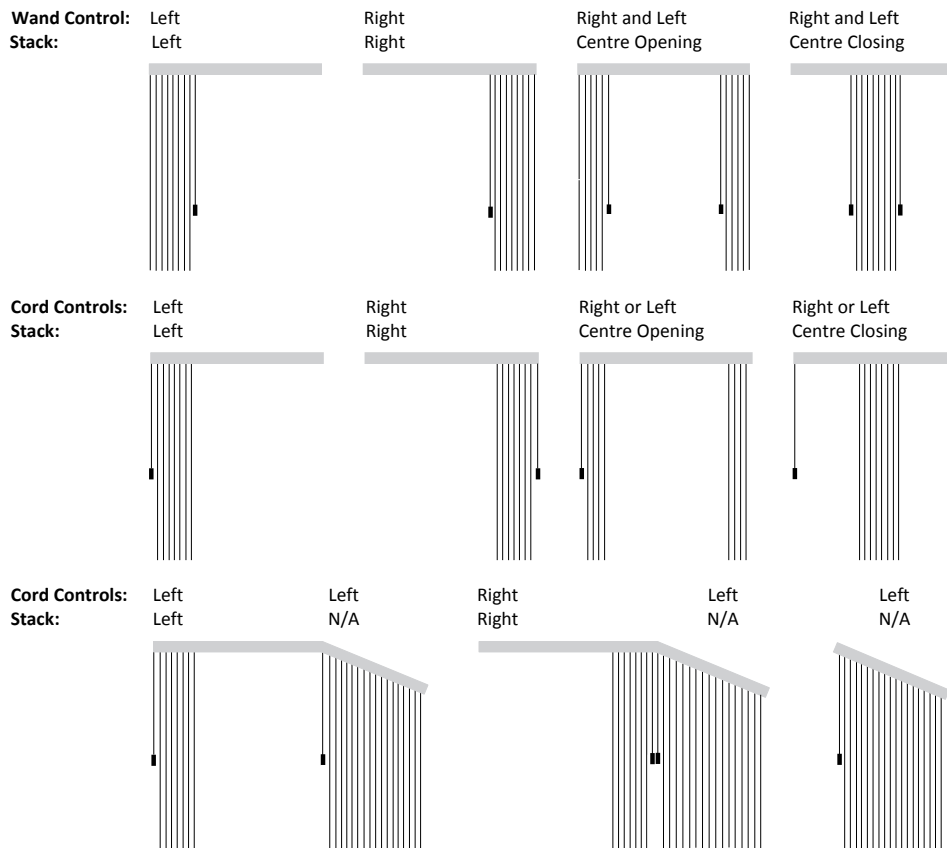

Specialty Options

Raking Head Window

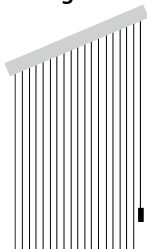

Inclination angle between 0° up to a maximum of 17° will not require a Trapezium Hook. Rotation of louvres 180 degree. Stacking is not available on raking head verticals.

Double Raking Head Window

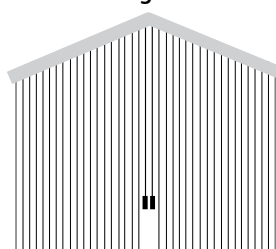

Inclination angle between 18° up to a maximum of 45° will require a Trapezium Hook. Rotation of louvres 180 degree. Stacking is not available on raking head verticals.

Raking Sill

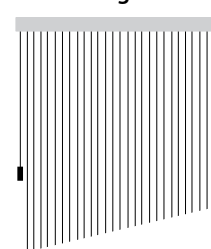

The greater sill inclination angle the greater stair impression. Stacking left or right towards the highest side.

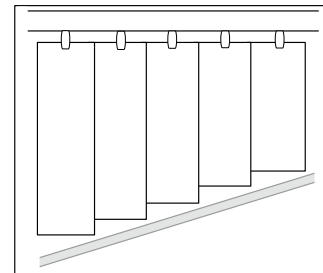
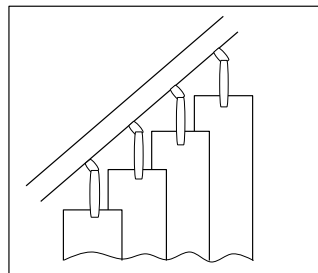
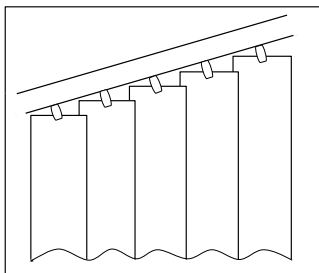

Stacking Formula

To determine the stacking measurement of a vertical, divide the width of the blind by 78mm (louvre spacing), then multiply by 9mm (width of carrier), then add 55mm (space between last louvre and the wall) e.g. 2500mm width ÷ 78 x 9 + 55 = 343mm.

Vertical Blinds - Hardware Overview



Exploded View

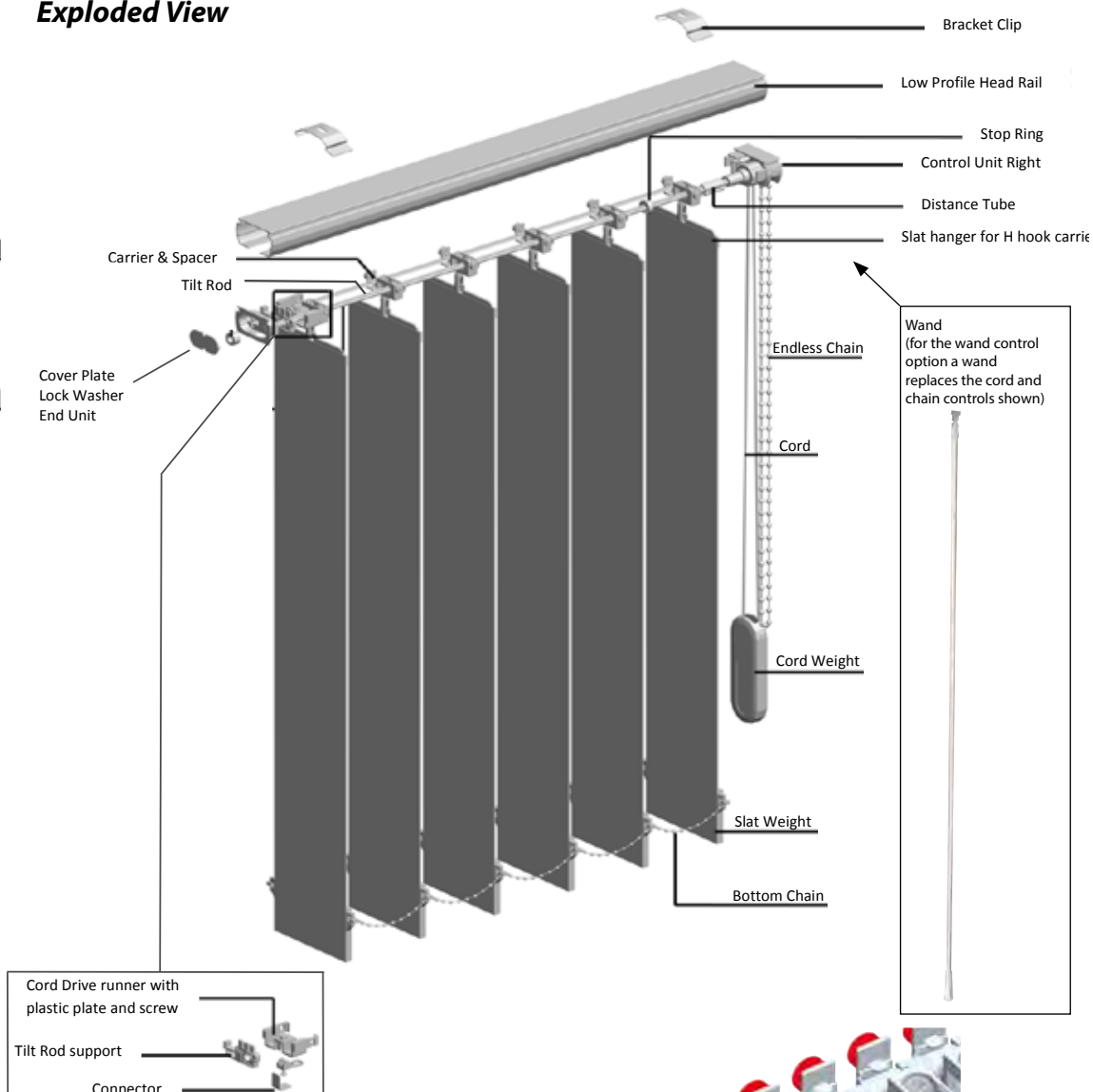

Carrier & Spacer

- Carrier & Spacer : (POM) Polyoxymethylene
- Type : Low Profile
- Clear H hook with plastic spacer

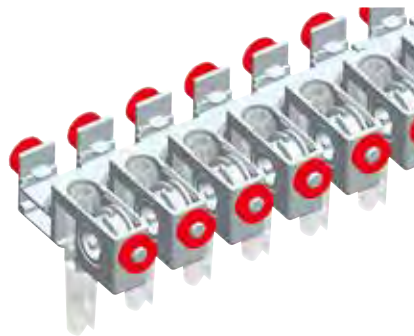

Trapezium Hook

- Trapezium Hook : PC (Poly Carbonate)
- Type : Short Hook for Carrier
- Colour : Clear



Slat Hanger

- Slat hanger for H Hook Carrier : (POM) Polyoxymethylene
- Type : Flexible, Double holes
- Size : 82mm to suit 89mm Louvre



SPECIFICATIONS

Sec. : Vertical
Date: Oct 2016

Head Rail

The elegant low profile curved side head rail design measuring just 45mm x 25mm deep gives a compact impression. The extrusion is +1mm of thickness which provides excellent rigidity and strength enabling blinds to be manufactured up to 4.0m wide.

- Head Rail : Aluminium
- Type : Low Profile Curved side
- Dimensions : 25mm x 45mm
- Thickness : 1.0mm
- Head rail colours : Silver, White, Ivory, Bronze, Black
- Louvre Light Gap : 7mm
- Frame Light Gap : 5mm

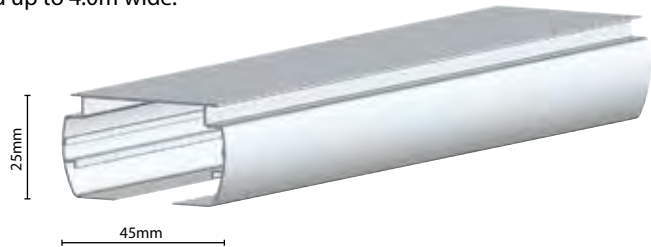

Fixing Bracket Clip

- Composition : Spring Steel - Nickel Plated
- Type : Snap-in system (front first then back)
- Thickness : 0.4mm



Extension Bracket

- Composition : Aluminium
- Size : 80mm x 30mm
- Thickness : 4mm
- Colours available : Silver, White, Ivory, Bronze, Black

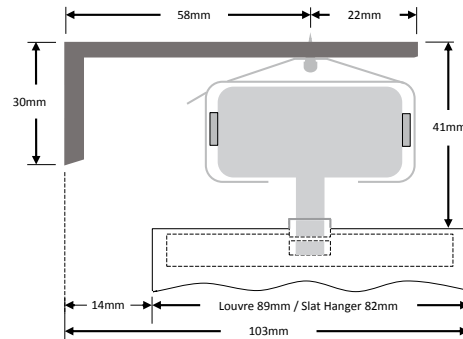

Recess Dimensions

Head Rail & Fixing Bracket Clip

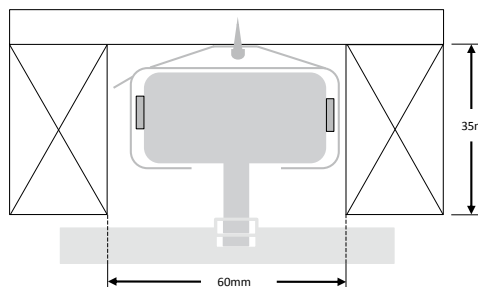

Head Rail, Fixing Bracket Clip and Louvre

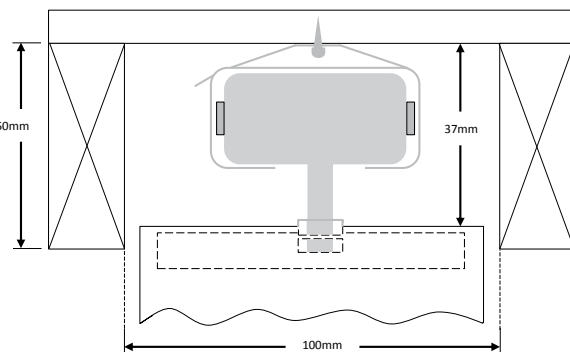

Vertical Blinds - Hardware Overview

SPECIFICATIONS

Control Chain

- Endless Ball Chain : Polyoxymethylene (POM)
- Size : 0.5m, 0.75m, 1m, 1.2m, 1.5m, 1.75m, 2m, 2.5m, 3m
- Ball Diameter : 4.5mm
- Ball Pitch : 6mm
- Colours available : White, Grey, Black



Cord Weight

- Cord Weight : ABS (Acrylonitrile-butadiene-styrene) for the white part
PC (Poly Carbonate) for the clear part
- Weight : Steel
- Colours available : White, Grey, Black

Cord

- Cord : Polyester (non-stretch)
- Diameter : 2.0mm
- Colours available : White, Grey, Black



Control Unit (cord control)

- Control Unit for Low Profile : Polyester (non-stretch)
- Colours available : White, Grey,



Wand Control

- Shaft : Powder coated aluminium
- Handle : PVC
- Colours available : White, Grey, Black

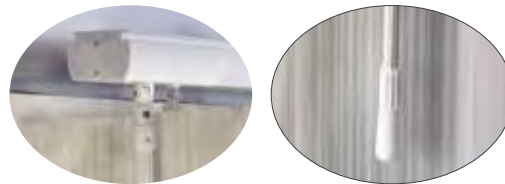

Bottom Chain

- Bottom Chain : Polyoxymethylene (POM) and Nylon
- Type : "C" clip
- Pitch between two clips : 89mm
- Beads between two clips : 8
- Colour : White

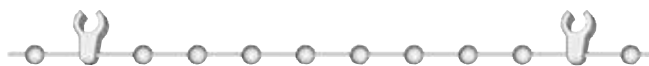

Four Ribbed Tilt Rod

- Tilt Rod : Aluminium
- Type : Four ribbed
- Diameter : 6mm



Cordless Bottom Weight

- Composition : Calcium Carbonate
- Size : 89mm
- Colour : White



Bottom Weight Option

- With bottom chain
- Composition : Calcium Carbonate
- Size : 89mm
- Colour : White





Vertical Blinds

SPECIFICATIONS



Sec. : Vertical
Date: Oct 2016

Vertical Blinds - Fabric Range

Blockout, Sunscreen



PVC free



Fade resistant



BLOCK-OUT OVERVIEW

Valencia, New Valencia, New Oxford, Trendz and Firenze ranges are Polyester (PVC free) block-out fabrics and are a very cost effective method to treat your windows. Fire retardant fabrics are available on request and all are resistant to mould and fungi, making them ideal installations in areas of high humidity and moisture.



Block-out



PVC free



High colour fastness to light



Mould and Fungi resistant



SUNSCREEN OVERVIEW

Techno Screen 5000 range is very cost effective and works well in both commercial and domestic situations. Techno Screen 5000 is dimensionally stable and comes in a wide range of colours in 5% openness. Is a fire retardant fabric with very high colour fastness (Grade 7-8) when subjected to sun rays.



High energy efficiency



Oeko-Tex® Standard 100



Excellent fire retardancy



Colour fastness Grade 7-8



5% openness



Sec. : Vertical
Date: Jun 2021

SPECIFICATIONS



Vertical Blinds - Fabric Range

Blockout, Sunscreen

SPECIFICATIONS

Type/Name	Composition	Fire Retardant	Openness
SUNSCREEN			
Techno 5000	30% Polyester, 70% PVC	Yes	5%
Techno 3000	30% Polyester, 70% PVC	Yes	3%
Techno 1000	30% Polyester, 70% PVC	Yes	1%
BLOCKOUT			
Valencia	100% Polyester, Acrylic Coated, PVC Free	No	N/A
New Valencia	100% Polyester (PVC Free)	No	N/A
New Valencia FR	100% Polyester, Acrylic Coated, PVC Free	Yes	N/A
New Oxford	100% Polyester (PVC Free)	No	N/A
New Oxford Premium FR	100% Polyester (PVC Free)	Yes	N/A
Firenze	100% Polyester, Acrylic Coated, PVC Free	No	N/A
Trendz	100% Polyester (PVC Free)	No	N/A

Sec. : Vertical
Date: Jun 2021

Magnetic Insect Screens

Product Overview

Magnetic Insect screens are economical and provide a very practical solution for keeping out those unwanted flies and insects.

One of the most important features of our Magnetic Insect Screens is the superior quality of the Phiferglass Pool & Patio Mesh. This high quality screen is a woven polyester fabric providing an unobstructed clear view. If required, block-out and sunscreen fabrics can be substituted for Insect screen. This can be a perfect alternative particularly for irregular shaped windows and or, for windows in out-of-reach places. Where space is limited and privacy is required such as a glass exterior door, a magnetic screen with a block out fabric can be a better option to a conventional roller or venetian blind.

Once the magnetic frame is attached to the window, it is very easy to remove and refit the screen simply by lifting the corner. We recommend regular dusting and if necessary marks may be removed with gentle cleaning using mild detergent and a damp cloth



Technical Data

Frames and Corners

Magnetic Insect Screens are made with durable 14mm wide PVC frames, strong magnets and special 40mm x 40mm 'easy lift' corners. The frames and 'easy lift' corners are available in a choice of five colours: Brown, Cream, Grey, Black, White.

Fabrics

Insect Screen

Phiferglass Pool & Patio Mesh

Sunscreen & Light filtering

Techno Screen 5000, 3000, 3000w (PVC coated polyester) and Techno Glass (PVC coated glass yarn) ranges are fire retardant and have a high colour fastness. Openness factors range from 1% up to 5%. Techno X, Serengetti Light filtering, Riviera Light Filtering. (Max size 750mm W x 2100mm D)

Block-out

Block-out fabric is constructed of Acrylic coated Polyester yarn. Fabrics available: Quebec Block-out, New Oxford, New Oxford FR, Premium 24 Block-out, Firenze Block-out. (Max size 750mm W x 2100mm D)



Size Limits	Minimum (mm)		Maximum (mm)	
	Width	Drop	Width	Drop
Insect Screen	100	100	1000*	2300*
Sunscreen & Light Filtering	100	100	750	2100
Block-out	100	100	750	2100

***Note: combined Width x Drop dimensions of Insect screen must not exceed maximum coverage of 2.3m²**

SPECIFICATIONS

Sec. : Magnetic
Date: Jul 2021



Motorisation

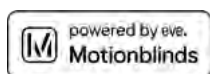
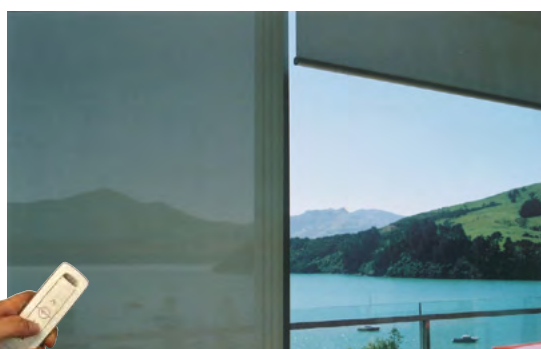
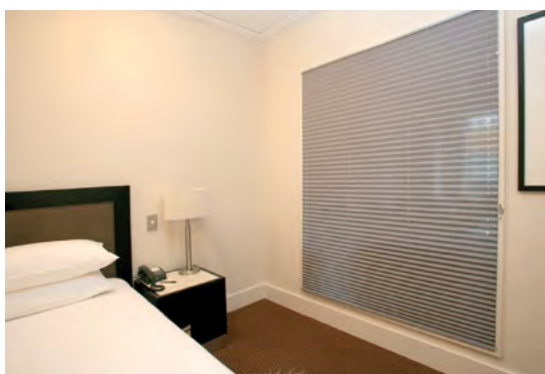

SPECIFICATIONS



Motorisation - overview

SPECIFICATIONS

Motorisation has been one of the main driving factors behind positioning Window Treatments' blinds and awnings as leaders in the market place.

Thanks to new technology in the motorisation industry we can now offer the option of remote controlled automation on most of our blinds and awnings.

Motorisation also eliminates the need for chains or cords and allows easy accessibility to high or difficult to reach windows. It is easily installed as retrofit and can be integrated with home or commercial building automation systems. At the press of a button, you can lower or retract your blinds to any point, individually or as a specified room or area grouping.

Motorisation by Window Treatments is provided by hard wired or wire free, electrically powered discreet and quiet tubular motors. They can be operated by wall mounted switch, remote control or interfaced with your building management or facade management system. The motors are installed directly into the blind head rail or tube. They are compact, quiet and can operate almost all sized blind. Window Treatments uses motors and control systems by French company Somfy®, Rollease Acmeda® and Dooya, all of whom are considered world leaders in automated systems and blind hardware.

Somfy®, Rollease Acmeda® and Dooya tubular motors are some of the world's quietest and with a radio receiver built inside, it is simply a matter of plugging them into a power point. Programming can then be managed easily with the use of the radio remote control or in most cases your smart phone/iPad etc.

Stress simulation tests are performed and their products are tested under extreme conditions. All motor systems are certified according to current technical and safety regulations.

Window Treatments, in conjunction with Somfy, Rollease Acmeda® and Dooya guarantee excellent product quality, installation and simplicity of use for all customers. Motors are guaranteed for five years.

Window Treatments can install motors or automated systems when you are remodelling or building a new home or commercial building, or we can retrofit to an existing system. We can convert most types of blinds and awnings.

Window Treatments automation systems are designed to improve your comfort, security and energy efficiency – making life easier. Our customer representatives throughout New Zealand as well as our Technical Services Manager, can consult with you or your architect at the planning stage for all domestic or commercial projects requiring automation.

Motorisation is available for:

- Skyight Blinds
- Honeycomb Pleated Blinds
- Palladio Folding Arm Awnings
- Venetian Blinds (Aluminium, New Image)
- Roller Blinds
- Blocco Blinds
- Italia Box
- Terrazza Conservatory & Pergola Awnings
- Mystique
- Louvre Roof's
- Securo® Exterior Blinds
- Securo® Interior Blinds
- Shutters

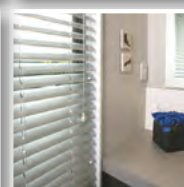
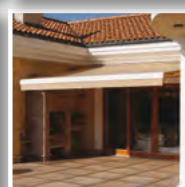
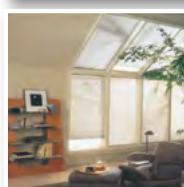
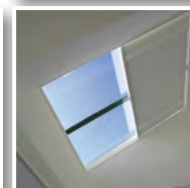
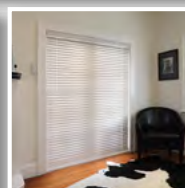
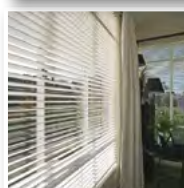

Sec. : Motorisation
Date: April 2024



Eve Motionblinds motors by Coulisse

SMART WINDOW COVERINGS POWERED BY EVE MOTIONBLINDS

Simply smarter – Eve Motionblinds works with Apple HomeKit, Google Home, Amazon Alexa, and/or Samsung SmartThings with built-in technologies Matter and Thread. Providing you have an existing border router or smart device such as a smart TV, smart lighting etc, there's no need for a bridge (Hub), registration or any cloud dependency so set-up is simple and secure.

Just scan the QR Code and your smart blinds or curtains will be part of your Smart ecosystem – letting your devices like lights, thermostats and security cameras talk to each other.

Operate your smart window coverings

Simply use your phone, download the free app and you are good to go. If you'd like a separate controller, see our section below.



Pull control

Override your blinds anytime with a simple manual pull



App control

Control from your smartphone anywhere in the world.



Voice control

Automate your blinds with a simple voice command



Remote control

Operate your blinds with the press of a button



Energy efficient

By interacting with other Apple HomeKit-enabled accessories, such as thermostats and lighting in your home, your window coverings can be automatically queued to offer the comfort level, ambiance and security you desire. Use the insulating properties of your blinds or curtains to heat in the winter and cool in the summer and you can create a healthier environment whilst saving energy.

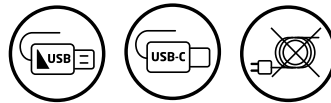

Convenience

- Quick and effortless setup
- No bridge installation
- No additional user accounts
- Local network and 100% data privacy
- Enhanced responsiveness and reach
- Cable-free installation
- Rechargeable with USB-C
- Control from anywhere
- Manual control available
- Automated home comfort settings
- Energy saving
- Total concept – blinds and curtains



Safety

Smart window coverings can be set to open and close at any time you require, which means your home seems inhabited even when you're away. Since there's no cloud-reliance, all data and intelligence are stored locally on the motor, so data exchanged in the home stays in the home.

Performances	Coulisse CM-30 Battery Motor
Torque	1.1nm
Voltage DC	12v
Rated Current (Amp)	1
Speed Max 28RPM	Low/Med/High
Operating Time	12 Min
Radio Frequency	433 MHz
Sound Level	56dB
IP Rating	IP20
Insulation Class	III
Battery Size	2600 mAh

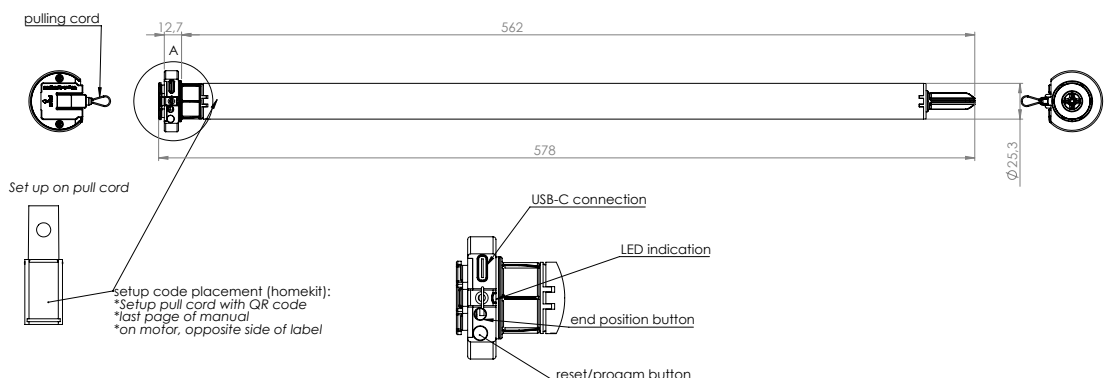

Sec. : Coulisse
Date : Apr 2024

SPECIFICATIONS

Somfy® Roller Blind Motorisation

- Wired



Window Treatments offers three wired motors capable of lifting up 19.6kg. Hardwired motors are always preferable, although Somfy battery blinds are available when hardwiring is not possible so it is important particularly for new builds that pre-wiring should be considered for any automation requirements.

Any blind on an 83mm tube requires an Altus 6/17 motor

Total Opening Width		50mm Tube								63mm Tube		83mm Tube		Multi-link Blinds Only							
		560	1000	1250	1500	1750	2000	2250	2500	2750	3000	3500	4000	4500	5000	5500	6000	6500	7000	7500	8000
Drop	1250	Green										Blue		Green							
	1500	Green										Blue		Green							
	1750	Green										Blue		Green							
	2000	Green										Blue		Green							
	2250	Green										Blue		Blue		Green				Red	
	2500	Green										Blue		Blue		Red		Red			
	2750	Green										Blue		Blue		Red		Red			
	3000	Green										Blue		Blue		Red		Red			
	3500	Green										Blue		Blue		Red		Red			

Key	Motor Type	Tube	Lifting Capacity
	Sonesse 3/30 Motor	50mm/63mm Tube	9.6kg
	Sonesse 6/20 Motor	50mm/63mm Tube	19.6kg
	Altus 6/17 Motor	83mm Tube	14.5kg

Minimum/Maximum Sizes

Window Treatments can produce a single motorised roller up to 5000mm wide with a 2250mm drop. As the width decreases, a larger drop is possible. Multi-link blinds can be produced up to 8000mm wide with a 4000mm drop, however we recommend blinds with drops exceeding 3500mm are installed with wire guides.

Performances	Sonesse 3/30	Sonesse 6/20	Altus 6/17
Torque	3nm	6nm	6nm
Nominal Voltage	230v	230v	230v
Rated Current	0.44	0.55	0.45
Rated Power	95W	120W	90W
Speed	30RPM	20RPM	17 RPM
Thermal Protection	4 Min	4 Min	4 Min
Radio Frequency	433.42	433.42	433.42
Sound Level (DB)	42	45	47
Cable Length	2500mm	2500mm	3000mm
IP Rating	IP 44	IP 44	IP 44
Insulation Class	II	II	I

Remote options

Hardwired and RTS (Radio Technology Somfy®) options are available. Hardwired; a maximum of five blinds or five groups of blinds can be controlled through a wall mounted remote. RTS allows for up to sixteen blinds or sixteen groups of blinds to be controlled wirelessly.



Situio 1 Remote



Situio 2 Remote



Situio 5 Remote



Telis 16 Channel



Telis 6 Chronis



Smoove Origin



Smoove UNO WT



Smoove DUO WT



Somfy® Roller Blind Motorisation

- Wiring - & Flush Connector Housing

To provide power to Somfy's wired motors, Window Treatments uses an Inline Connector and when requested, conceals the Inline Connector inside a Flush Connector Housing. The RTS Inline Connector has a two core cable while the non-RTS Inline Connector has a three core cable. This allows rewiring from a non-RTS control to a RTS control.

Flush Connector Housing

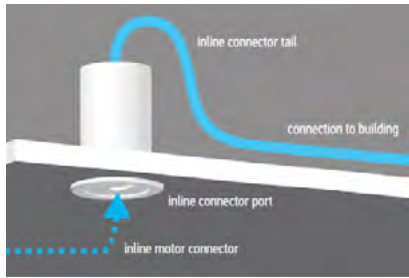

Technical Data	
Item Number	9026397
Item Description	Flush Connector Housing
Size	67 x 22 x 25mm
Colour	White
Patented Design	Au Pat 2018100721

Example of connection and recess sizing for a Single Motorised Roller Blind

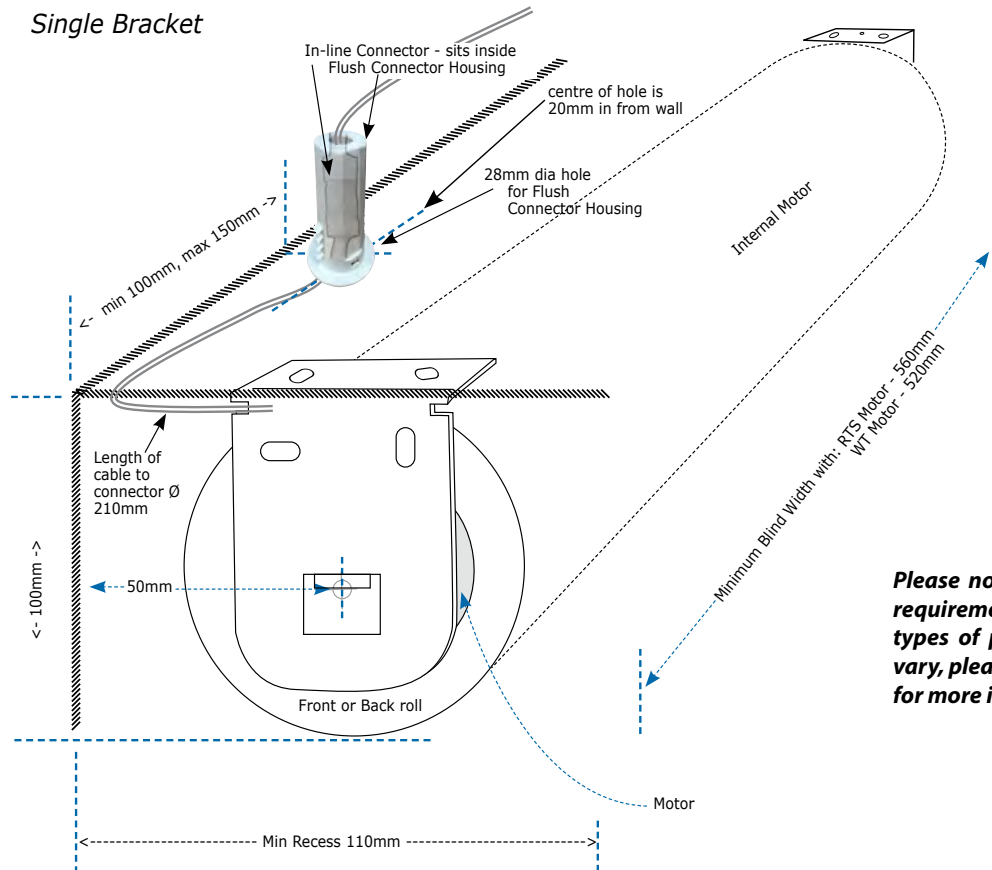

Please note: electrical requirements for other types of product may vary, please contact us for more information

Power supply and A connection - incorrect wiring systems:

<p>Parallel Wiring</p> <p>Do not wire Somfy® standard motors in parallel. Each motor requires its own switch or relays. If group control is required contact us for the required controller and wiring information.</p>	<p style="color: red; text-align: center;">!! Do not wire motors in parallel !!</p>
<p>Multiple Switching</p> <p>Do not wire one motor directly to more than one switch. If multiple switching is required contact us for the required controller and wiring information.</p>	

Somfy® Roller Blind Motorisation - CONNEXOON

The Somfy® Connexoon app allows control of your motorised blinds via your smartphone devices whether you are at home or away. Scheduled time control allows automatic operation to help with light and heat control throughout the day. Each Connexoon can connect up to four smart devices allowing control of up to 30 Individual or 30 groups of RTS products. IFTTT compatible allows the ability to control via third party voice assistants including Google Home and Amazon Alexa.

Somfy® CONNEXOON Technical Characteristics	
Operating temperature	0°C to 45°C
Protection Rating	IP 30
Radio Frequency	RTS: 433.42 MHz
Radio Hz Range	200metres in open field, 20 metres through 2 reinforced concrete walls
Dimensions (H x W x D mm)	110 x 71 x 24 (without plug)



App for Phone & Tablet

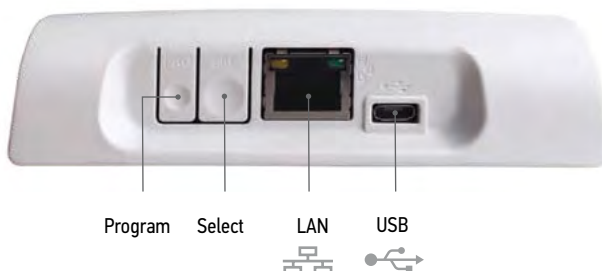

Please note: electrical requirements for other types of product may vary, please contact us for more information It is important that your electrical professional is given the correct specifications and information at the wiring stage of construction therefore please arrange for your electrical professional to contact our Technical Services Manager Acko Atkins with your project information. Ph (03) 343 6175 DDI, or 027 439 8287, Email: acko.atkins@window-treatments.co.nz

Somfy® Blocco Roller Blind Motorisation - Wired & Wire Free

Window Treatments offers a Somfy wired motor capable of lifting up 9.6kg. Hardwired motors are always preferable, although Somfy battery blinds are available when hardwiring is not possible so it is important particularly for new builds that pre-wiring should be considered for any automation requirements.

Total Opening Width		Maximum sizes with Somfy Motorisation - S45 Tube									
Drop		610	1000	1250	1500	1750	2000	2250	2500	2750	3000
1250											
1500											
1750											
2000											
2250											
2500											
2750											
3000											

Contact Window Treatments for these sizes

Key	Motor Type	Tube	Lifting Capacity
	Somfy 1.5nm Battery	S45	6.0kg
	Somfy 2.0nm Battery	S45	8.0kg
	Sonesse 3/30 Motor	S45	9.6kg

Performances	Battery 1.5	Battery 2.0	Sonesse 3/30
Torque	1.5nm	2nm	3nm
Nominal Voltage	12 v	12v	230v
Rated Current	-	-	0.44
Rated Power	-	-	95W
Speed	10-20-28RPM	10-20-28RPM	30RPM
Thermal Protection			4 Min
Radio Frequency	433.42 MHz	433.42 MHz	433.42 MHz
Sond Level (DB)	54dB	44dB	42dB
Cable Length	-	-	2500mm
IP Rating	IP 20	IP 30	IP 44
Insulation Class	III	III	II

Remote options

Hardwired and RTS (Radio Technology Somfy®) options are available. Hardwired; a maximum of five blinds or five groups of blinds can be controlled through a wall mounted remote. RTS allows for up to sixteen blinds or sixteen groups of blinds to be controlled wirelessly.



Remote

Situ 2 Remote

Situ 5 Remote

Telis 16 Channel

Telis 6 Chronis

Smooove Origin



Sec. : Blocco
Date : May 2021



Somfy® Blocco Roller Blind Motorisation

- Wiring - Inline Connector & Flush Connector Housing

To provide power to Somfy's wired motors, Window Treatments uses an Inline Connector and when requested, conceals the Inline Connector inside a Flush Connector Housing. The RTS Inline Connector has a two core cable while the non-RTS Inline Connector has a three core cable. This allows rewiring from a Non-RTS control to a RTS control.

Below are wiring diagrams for both options:

RTS Inline Connector (Two Core Cable)

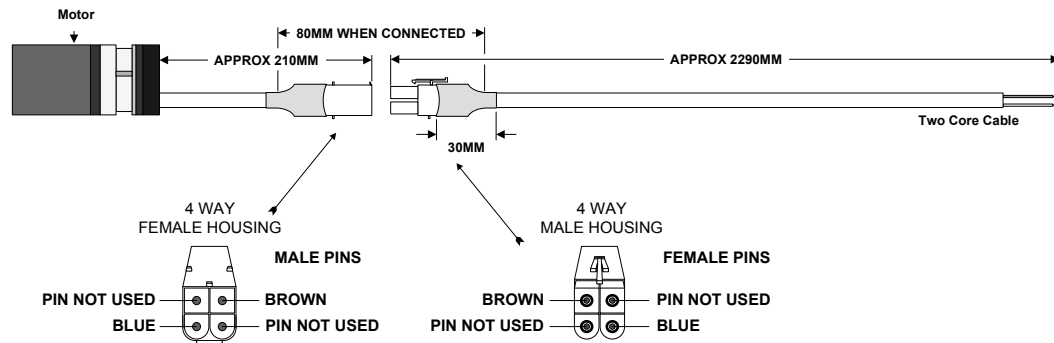

In-Line Connector and Housing Fitted

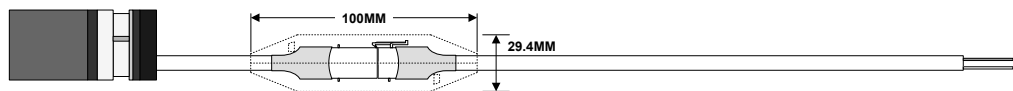

Non-RTS Inline Connector (Three Core Cable)

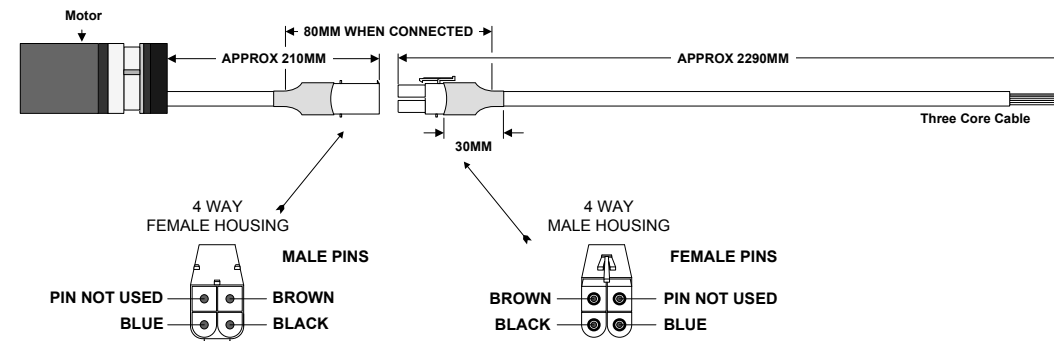

In-Line Connector and Housing Fitted

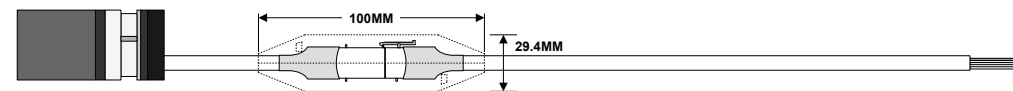

Flush Connector Housing

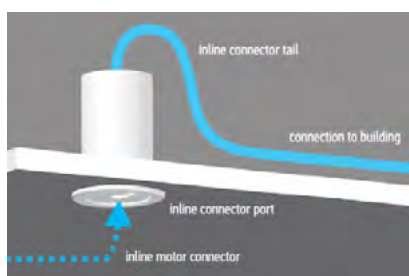

Technical Data	
Item Number	9026397
Item Description	Flush Connector Housing
Size	67 x 22 x 25mm
Colour	White
Patented Design	Au Pat 2018100721

Sec. : Blocco
Date: May 2021

SPECIFICATIONS

Somfy® Blocco Roller Blind Motorisation - Electrical requirements

Example of connection and recess sizing for a Single Motorised Roller Blind

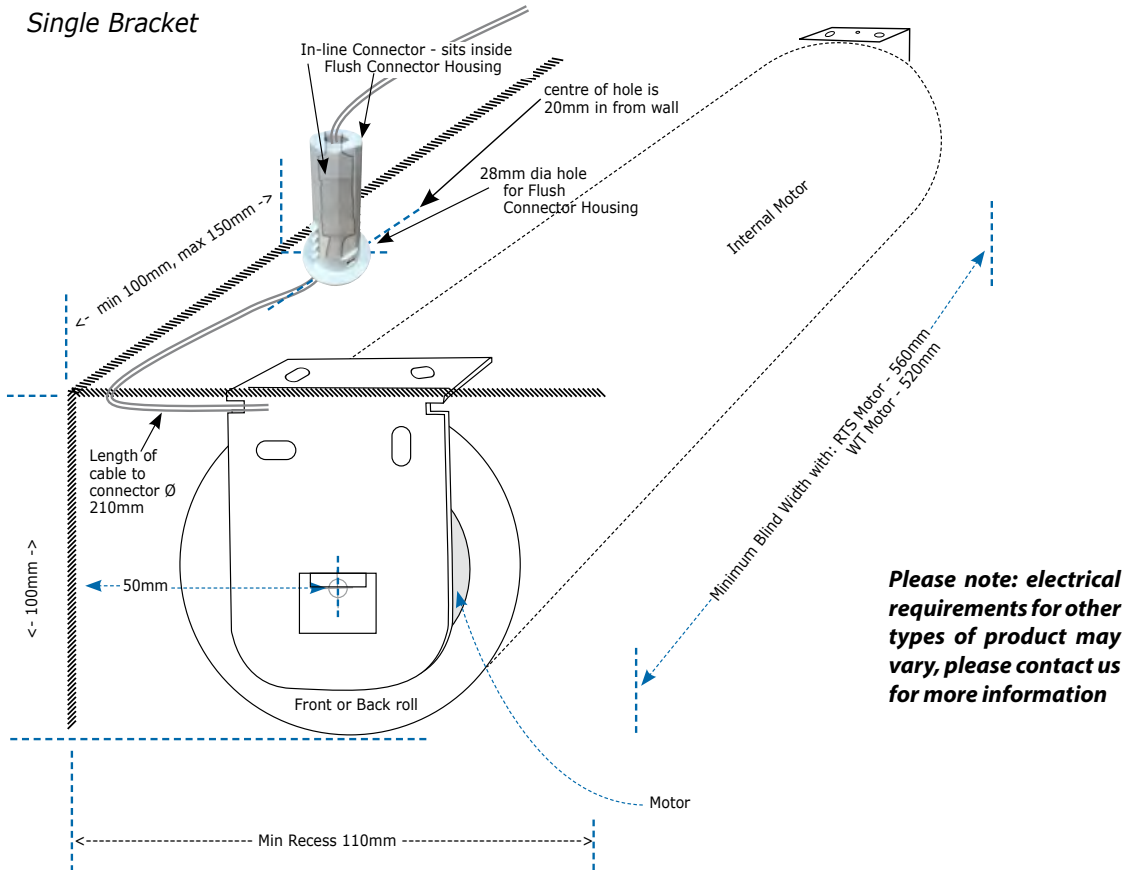

Power supply and A connection - incorrect wiring systems:

Parallel Wiring

Do not wire Somfy® standard motors in parallel. Each motor requires its own switch or relays.
 If group control is required contact us for the required controller and wiring information.

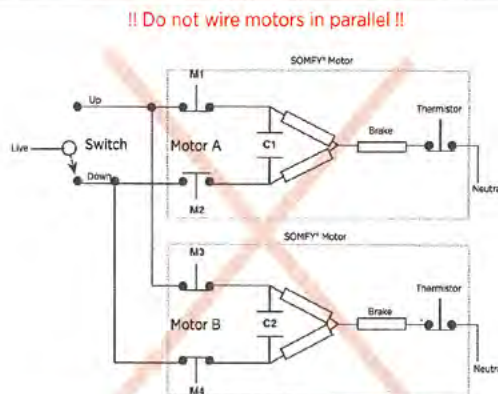

Multiple Switching

Do not wire one motor directly to more than one switch.
 If multiple switching is required contact us for the required controller and wiring information.

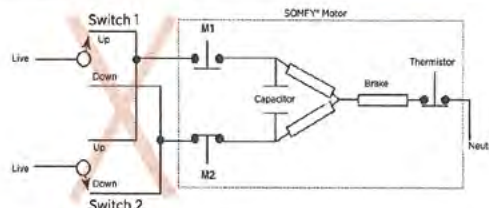

SPECIFICATIONS



Somfy® Blocco Roller Blind Motorisation - CONNEXOON

The Somfy® Connexoon app allows control of your motorised blinds via your smartphone devices whether you are at home or away. Scheduled time control allows automatic operation to help with light and heat control throughout the day. Each Connexoon can connect up to four smart devices allowing control of up to 30 Individual or 30 groups of RTS products. IFTTT compatible allows the ability to control via third party voice assistants including Google Home and Amazon Alexa.

Somfy® Connexoon Technical Characteristics	
Operating temperature	0°C to 45°C
Protection Rating	IP 30
Radio Frequency	RTS: 433.42 MHz
Radio Hz Range	200metres in open field, 20 metres through 2 reinforced concrete walls
Dimensions (H x W x D mm)	110 x 71 x 24 (without plug)

App for Phone & Tablet



Situ 1 Remote



Situ 2 Remote



Situ 5 Remote



Telis 16 Channel



Telis 6 Chronis



Program Select LAN USB



Smoove Origin



Please note: electrical requirements for other types of product may vary, please contact us for more information

It is important that your electrical professional is given the correct specifications and information at the wiring stage of construction therefore please arrange for your electrical professional to contact our Automation & Technician Specialist Acko Atkins with your project information.

Helpful information to have available when you ring or email is : Client name, your Window Treatments NZ Ltd Consultants name, product type and if possible the Window Treatments NZ Ltd Job Number.

**Acko Atkins - Automation & Technician Specialist,
Window Treatments NZ Ltd, Head Office
218 Main South Road, Christchurch,
Postal Address: P O Box 6260, Upper Riccarton, Chch 8442
Ph (03) 343 6175 DDI
Mobile 027 439 8287
Email acko.atkins@window-treatments.co.nz**

Sec. : Blocco
Date: May 2021

SPECIFICATIONS

Horizontal Blinds - Somfy Motorisation

Horizontal Blinds - Motorisation

Motorisation control is available on Aluminium 25mm & 50mm venetians and New Image 50mm & 63mm Blinds. Automation is via Somfy's range of Sonesse motors. These ultra-quiet motors set the standard for internal blind automation. Somfy's wide range of control options include hand held radio remote control with a scroll wheel for precision tilt positioning, timers, and even a full building management system. Window Treatments NZ Ltd is an authorized Somfy automation specialist.

240 Volt AC Motor: Sonesse 40

Performances	Sonesse 3/30	Sonesse 6/20
Torque	3nm	6nm
Nominal Voltage	230v	230v
Rated Current	0.44	0.55
Rated Power	95W	120W
Speed	30RPM	20RPM
Thermal Protection	4 Min	4 Min
Radio Frequency	433.42	433.42
Sound Level (DB)	42	45
Cable Length	2500mm	2500mm
IP Rating	IP 44	IP 44
Insulation Class	II	II

Blind Type >	Aluminium 50mm	New Image
Min Width	665mm	665mm
Max Width	2400mm	1800mm
Min Drop	300mm	300mm
Max Drop	2400mm	2100mm

Smoove Origin



RTS Radio Transmitted Signal - Wireless :

Situo 1 Remote



Situo 2 Remote



Situo 5 Remote



Telis 16 Channel



Telis 6 Chronis



Telis Mod/Var with scroll wheel



Scroll wheel for precise adjustment of horizontal blind slats

Wall switches or Remote controls can be used to manage a blind or groups of blinds with tilting slats equipped with RTS technology as well as activate or take control of a sun sensor. With the Telis Mod/Var with Scroll Wheel, slats are precisely positioned using a central thumbwheel. Up, down, stop and preferred position settings are achieved using the « my » key. Available in Pure, Silver and in single channel model



Awnings - Somfy Motorisation Italia Box

Motorisation



Window Treatments' motorised awnings are surprisingly simple and inexpensive. All awning systems can be automated using Somfy's range of motors. These robust motors set the standard for awning automation. Somfy's wide range of weather sensor options include sun, wind and rain control.

An automated awning is capable of extending or retracting automatically when it is needed. The benefits of this include protecting your awning from wind damage, making the building appear occupied, and maintaining a comfortable indoor temperature which can reduce cooling costs. A variety of control options are available to suit different automation requirements such as individual control, multiple control, group control, master control or automatic control using weather sensors.

Window Treatments NZ Ltd is an Authorised Somfy Automation Expert. For further information on how a Somfy Automated solution can enhance your design, please contact motorisation@window-treatments.co.nz

Italia Box Motorisation (optional)

Italia Box uses six different types of motors for automation depending on the size of the awning installation. Refer to Motor selection chart.

Motor Selection		Width <2.5m	Width >2.5m	4 Arms
Italia Box	RTS	Altus 15/17	Altus 25/17	Altus 40/17
	WT	Jet 10/17	Gemini 25/17	Mariner 40/17

KEY:
 WT = Mechanical switch hardwired to the motor.
 RTS = Remote control (handheld or wallmounted)
 Maximum Width: 4.5m
 Maximum Projection: 1.4m

Performances	Altus 15/17	Jet 10/17	Altus 25/17	Gemini 25/17	Altus 40/17	Mariner 40/17
Torque	15 Nm	10 Nm	25 Nm	25 Nm	40 Nm	40 Nm
Nominal Voltage	230v	230v	230v	230v	230v	230v
Rated Current	0.65 A	0.5 A	0.8 A	0.8 A	1.2 A	1.2 A
Rated Power	140W	120W	170W	170W	270W	270W
Speed	17 RPM	17 RPM	17 RPM	17 RPM	17 RPM	17 RPM
Thermal Protection	4 Min	4 Min	4 Min	4 Min	4 Min	4 Min
Radio Frequency	433.42	433.42	433.42	433.42	433.42	433.42
Sound Level (DB)	50	47	56	56	57	57
Cable Length	3000mm	2500mm	3000mm	2500mm	3000mm	2500mm
IP Rating	IP 44	IP 44	IP 44	IP 44	IP 44	IP 44
Insulation Class	I	I	I	I	I	I

Somfy Sensors

Weather Sensors can be used for automatic control. These include rain, wind and sun sensors. Rain and wind sensors will retract your awning when it is raining, or if wind speeds exceed 35 km/h. The sun sensor works on light level and can be programmed to a specific light level.

Sunis Wirefree RTS Sun Sensor



Wind Sensor



Ondeis Rain Sensor



Remote Control



Hard Wire Switch



Motion Sensor



Sec. : Awnings
Date: Aug 2018

SPECIFICATIONS

Awnings - Somfy Motorisation Palladio

Window Treatments' motorised awnings are surprisingly simple and inexpensive. All awning systems can be automated using Somfy's range of motors. These robust motors set the standard for awning automation.

Somfy's wide range of weather sensor options include sun, wind and rain control.



An automated awning is capable of extending or retracting automatically when it is needed (note: pitch can only be manually adjusted). The benefits of this include protecting your awning from wind damage, making the building appear occupied, and maintaining a comfortable indoor temperature which can reduce cooling costs. A variety of control options are available to suit different automation requirements such as individual control, multiple control, group control, master control, automatic control using weather sensors and manual override in the event of power failure (Only when model CSI 40/12 motor is used). Awnings are installed by Window Treatments installers with Somfy 230v Tubular motors which are housed inside the awning tube. The motors have a 3m power flex which is to be connected to the power supply by a registered Electrician. Window Treatments can recommend an electrician to complete this work if necessary.

Window Treatments NZ Ltd is an Authorised Somfy Automation Expert. For further information on how a Somfy Automated solution can enhance your design, please contact motorisation@window-treatments.co.nz

Palladio Motorisation (optional)

Palladio uses six different types of motors for automation depending on the size of the awning installation. Refer to Motor selection chart.

Motor Selection		Projection <2.6m	Proj >2.6m	KEY: WT = Mechanical switch hardwired to the motor. RTS = Remote control (handheld or wallmounted) Maximum Width:7m Maximum Projection: 3.6m
Palladio	RTS	Altus 25/17	Altus 40/17	
	WT	Gemini 25/17	Mariner 40/17	

Performances	Altus 25/17	Gemini 25/17	Altus 40/17	Mariner 40/17	Mariner CSI 40/12
Torque	25 Nm	25 Nm	40 Nm	40 Nm	40 Nm
Nominal Voltage	230v	230v	230v	230v	230v
Rated Current	0.8 A	0.8 A	1.2 A	1.2 A	1.1A
Rated Power	170W	170W	270W	270W	240W
Speed	17 RPM	17 RPM	17 RPM	17 RPM	12 RPM
Thermal Protection	4 Min	4 Min	4 Min	4 Min	4 Min
Radio Frequency	433.42	433.42	433.42	433.42	433.42
Sound Level (DB)	56	56	57	57	55
Cable Length	3000mm	2500mm	3000mm	2500mm	2500mm
IP Rating	IP 44	IP 44	IP 44	IP 44	IP 44
Insulation Class	I	I	I	I	I
Manual Override	No	No	No	No	Yes - RTS Motor, RH Control only

Somfy Sensors

Weather Sensors can be used for automatic control. These include rain, wind and sun sensors. Rain and wind sensors will retract your awning when it is raining, or if wind speeds exceed 35 km/h. The sun sensor works on light level and can be programmed to a specific light level.



SPECIFICATIONS

Motorisation



Terrazza awnings are automated using Somfy's range of motors. These robust motors set the standard for awning automation. Somfy's wide range of weather sensor options include sun, wind and rain control.

Motorisation of the Terrazza awning (with sensor options) allows you to extend or retract the awning automatically when it is needed. The benefits of this include protecting your Terrazza awning from wind damage, making the building appear occupied, and maintaining a comfortable indoor temperature which can reduce cooling costs. A variety of control options are available to suit different automation requirements such as individual control, multiple control, group control, master control or automatic control using weather sensors.

Window Treatments NZ Ltd is an Authorised Somfy Automation Expert. For further information on how a Somfy Automated solution can enhance your design, please contact motorisation@window-treatments.co.nz

Terrazza Motorisation

Terrazza uses four different types of motors for automation depending on the size of the installation. Refer to Motor selection chart.

Motor Selection		<6m ²	>6m ²
Terrazza	RTS	Altus 25/17	Altus 40/17
	WT	Gemini 25/17	Mariner 40/17

KEY:
 WT = Mechanical switch hardwired to the motor.
 RTS = Remote control (handheld or wallmounted)
 Maximum Width:4.0m
 Maximum Projection: 4.0m
 Note: Maximum coverage must not exceed 12m²

Performances	Altus 25/17	Gemini 25/17	Altus 40/17	Mariner 40/17
Torque	25 Nm	25 Nm	40 Nm	40 Nm
Nominal Voltage	230v	230v	230v	230v
Rated Current	0.8 A	0.8 A	1.2 A	1.2 A
Rated Power	170W	170W	270W	270W
Speed	17 RPM	17 RPM	17 RPM	17 RPM
Thermal Protection	4 Min	4 Min	4 Min	4 Min
Radio Frequency	433.42	433.42	433.42	433.42
Sound Level (DB)	56	56	57	57
Cable Length	3000mm	2500mm	3000mm	2500mm
IP Rating	IP 44	IP 44	IP 44	IP 44
Insulation Class	I	I	I	I

Somfy Sensors

Weather Sensors can be used for automatic control. These include rain, wind and sun sensors. Rain and wind sensors will retract your awning when it is raining, or if wind speeds exceed 35 km/h. The sun sensor works on light level and can be programmed to a specific light level.



Securo® - Motorisation by Somfy



Motorisation option - Securo 75-110

Window Treatments NZ Ltd offers a motorized option for most styles of Securo®s through Somfy motorisation. This includes RTS and Wired motors as well as remotes, wall mounted switches, optional wind and light sensors and the ability to be linked with a building management system. Securo® 75-110 Channel Guide/Wire Guide uses one of three different motors for automation depending on the size of your application

Motor Selection		<6m ²	>6m ²
Securo 75-110	RTS	Altus 15/17	Altus 15/17
	WT	Ariane 6/17	Jet 10/117

KEY:
 WT = Mechanical switch hardwired to the motor.
 RTS = Remote control (handheld or wallmounted)
 Maximum Width: 4.6m
 Maximum Drop: 3.0m (subject to fabric choice)

Performances	Altus 15/17	Ariane 6/17
Torque	15 Nm	6 Nm
Nominal Voltage	230v	230v
Rated Current	0.65 A	0.4 A
Rated Power	140W	90W
Speed	17 RPM	17 RPM
Thermal Protection	4 Min	4 Min
Radio Frequency	433.42	-
Sound Level (DB)	50	46
Cable Length	3000mm	2500mm
IP Rating	IP 44	IP 44
Insulation Class	I	I

Somfy Sensors

Weather Sensors can be used for automatic control. These include wind and sun sensors. Wind sensors will retract your awning if wind speeds exceed 35 km/h. The sun sensor works on light levels and can be programmed to a specific light level.

Eolis RTS Wind Sensor Soliris RTS- Sun & Wind Sensor



Sunis Wirefree RTS Sun Sensor



Motorisation - Securo® Max Channel Guide/Wire Guide

Window Treatments NZ Ltd offers a motorised option for most styles of Securo®s through Somfy motorisation. This includes RTS and Wired motors as well as remotes, wall mounted switches, optional wind and light sensors and the ability to be linked with a building management system. Securo® Max Channel Guide/Wire Guide uses one of four different motors for automation depending on the size of your application

Motor Selection		<10m ²	>10m ²
Securo Max	RTS	Altus 15/17	Altus 25/17
	WT	Jet 10/17	Gemini 25/17

KEY:
 WT = Mechanical switch hardwired to the motor.
 RTS = Remote control (handheld or wallmounted)
 Maximum Width: 10m
 Maximum Drop: 3.0m

Performances	Altus 15/17	Jet 10/17	Altus 25/17	Gemini 25/17
Torque	15 Nm	10 Nm	25 Nm	25 Nm
Nominal Voltage	230v	230v	230v	230v
Rated Current	0.65 A	0.5 A	0.8 A	0.8 A
Rated Power	140W	120W	170W	170W
Speed	17 RPM	17 RPM	17 RPM	17 RPM
Thermal Protection	4 Min	4 Min	4 Min	4 Min
Radio Frequency	433.42	433.42	433.42	433.42
Sound Level (DB)	50	47	56	57
Cable Length	3000mm	2500mm	3000mm	2500mm
IP Rating	IP 44	IP 44	IP 44	IP 44
Insulation Class	I	I	I	I

Somfy Sensors

Weather Sensors can be used for automatic control. These include wind and sun sensors. Wind sensors will retract your awning if wind speeds exceed 35 km/h. The sun sensor works on light levels and can be programmed to a specific light level.

Eolis RTS Wind Sensor Soliris RTS- Sun & Wind Sensor



Sunis Wirefree RTS Sun Sensor



Sec. : Securo
 Date : Jun 2020

SPECIFICATIONS



Café Blind - Somfy Motorisation

Motorisation - Café Blind

Window Treatments NZ Ltd offers a motorized option for Café Blinds through Somfy motorisation. This includes RTS and Wired motors as well as remotes, wall mounted switches and the ability to be linked with a building management system.

Café Blinds use one of four different motors for automation depending on the size of your application

Motor Selection		<10m ²	>10m ²
Securo Max	RTS	Altus 15/17	Altus 25/17
	WT	Jet 10/17	Gemini 25/17

KEY:
 WT = Mechanical switch hardwired to the motor.
 RTS = Remote control (handheld or wallmounted)
 Maximum Width: 10m
 Maximum Drop: 3.0m

Performances	Altus 15/17	Jet 10/17	Altus 25/17	Gemini 25/17
Torque	15 Nm	10 Nm	25 Nm	25 Nm
Nominal Voltage	230v	230v	230v	230v
Rated Current	0.65 A	0.5 A	0.8 A	0.8 A
Rated Power	140W	120W	170W	170W
Speed	17 RPM	17 RPM	17 RPM	17 RPM
Thermal Protection	4 Min	4 Min	4 Min	4 Min
Radio Frequency	433.42	433.42	433.42	433.42
Sound Level (DB)	50	47	56	57
Cable Length	3000mm	2500mm	3000mm	2500mm
IP Rating	IP 44	IP 44	IP 44	IP 44
Insulation Class	I	I	I	I

Note:

Somfy automatic Wind and Sun sensors are not suitable for Café Blinds given that the bottom rail is physically anchored to the ground when the blind is in the down position.

SPECIFICATIONS

Rollease Acmeda - Roller Blind Motorisation



Window Treatments offers three wirefree and wired motors capable of lifting up to 9.6kg. The Li-ion Battery powered motors are great for hard to reach places, especially when equipped with a solar panel. With the blinds being raised and lowered once a day, battery power will last approximately 3 months depending on fabric weight. A charging cable is provided and must be connected to the motor for 6 hours to provide optimum charge (standard 4mtr length supplied, 0.22mtr, 1.22mtr and 2.44mtr extensions available as optional extras). Alternatively, a solar panel charger can be fitted in the window to keep the motor charged allowing two cycles per day (once up and once down).

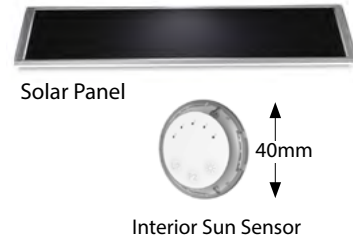

Minimum/Maximum Sizes

Window Treatments can produce a battery powered motorised roller blind to any size shown on the table. If your window is larger than our maximum size, our wired motorization offers more lifting capacity. Note: the minimum size for a wirefree multilink roller blind is 750mm.

Min - Max Blind Width for Li-ion Battery Motors

	1 Blind 1 Motor 38/50mm Tube						1 Blind 1 Motor 50mm Tube				2 or 3 Blinds 1 Motor 50mm Tube						
Drop	530	705	1000	1250	1500	1750	2000	2250	2500	2750	3000	3500	4000	4500	5000	5500	6000
1250																	
1500																	
1750																	
2000																	
2250																	
2500																	
2750																	
3000																	
3500																	

Key	Motor Type	Tube	Lifting Capacity
Yellow	1.1Nm Battery Motor	38mm/50mm Tube	3.6kg
Light Green	2.0Nm Battery Motor	50mm Tube	6.6kg
Dark Green	3.0Nm Battery Motor	50mm Tube	9.6kg
Black	6.0Nm Wired Motor	50mm Tube	24kg

Performances	Li-ion 1.1 Short Battery Motor	Li-ion 1.1 Battery Motor	Li-ion 2.0 Battery Motor	Li-ion 3.0 Battery Motor	Automate E6 Hardwired Motor	Automate M6 Hardwired Motor
Torque	1.1nm	1.1nm	2nm	3nm	6nm	6nm
Nominal Voltage	12v	12v	12v	12v	240v	240v
Rated Current (Amp)	0.96	0.96	1.25	0.83	0.85	0.85
Speed	20-24-28RPM	20-24-28RPM	20-24-28RPM	20-24-28RPM	33RPM	33RPM
Thermal Protection	12 Min	12 Min	12 Min	12 Min	4 Min	4 Min
Radio Frequency	433.92MHz	433.92MHz	433.92MHz	433.92MHz	433.92MHz	433.92MHz
Sound Level (DB)	46dB	46dB	46dB	53dB	44dB	44dB
IP Rating	IP 20	IP 20	IP20	IP 44	IP 44	IP 44
Insulation Class	III	III	III	III	III	III
Battery Size	1600mAH	2000mAH	2200mAH	5200mAH		

Technologies

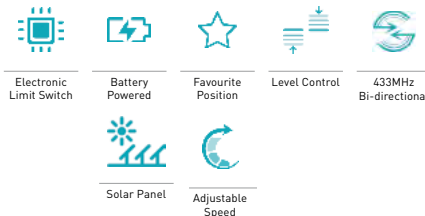

Compatibility Chart	Li-ion 1.1	Li-ion 2.0	Li-ion 3.0	Automate E6
Controller - Pulse	Y	Y	Y	Y
Controller - Paradigm	Y	Y	Y	Y
Sensor- Interior Sun Sensor	Y	Y	Y	Y
Sensor - Solar Wind & Light	-	-	-	-
Sensor Motion Sensor	-	-	-	-

SPECIFICATIONS



RollEase® Acmeda - Roller Blind Motorisation

To provide power to RollEase wired motors, Window Treatments uses an Inline Connector and when requested, conceals the Inline Connector inside a Flush Connector Housing. The RTS Inline Connector has a three core cable while the non-RTS Inline Connector has a four core cable. This allows rewiring from a non-RTS control to a RTS control

Flush Connector Housing

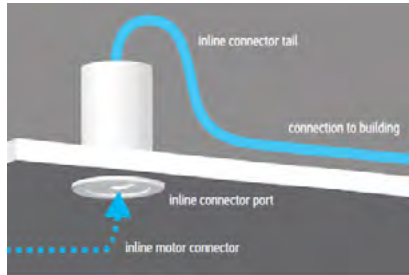

Technical Data	
Item Number	9026397
Item Description	Flush Connector Housing
Size	67 x 22 x 25mm
Colour	White
Patented Design	Au Pat 2018100721

- Electrical requirements

Example of connection and recess sizing for a Single Motorised Roller Blind

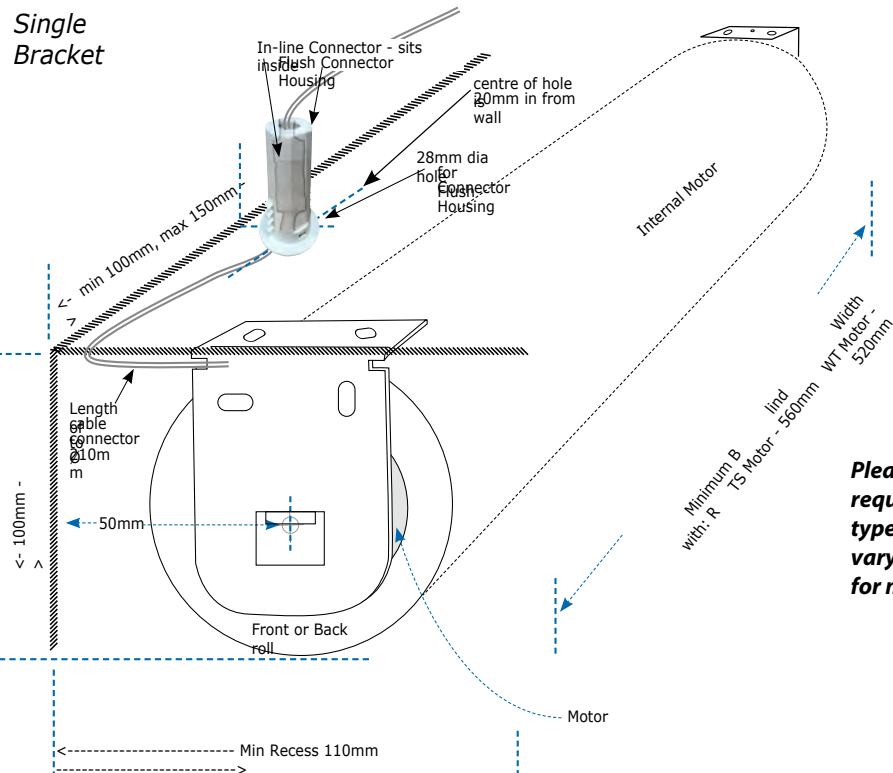

Please note: electrical requirements for other types of product may vary, please contact us for more information

Power Options:

Parallel Wiring - Do not wire RollEase® standard motors in parallel. Each motor requires its own switch or relays. If group control is required contact us for the required controller and wiring information.

Multiple Switching Wiring - Do not wire one motor directly to more than one switch. If multiple switching is required contact us for the required controller and wiring information.

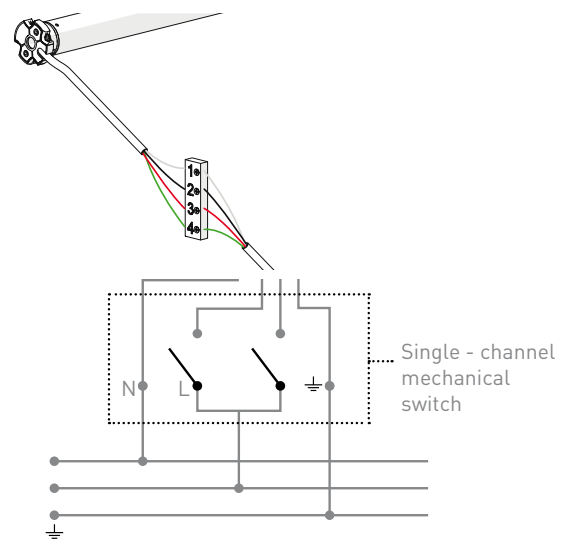

SPECIFICATIONS



RollEase® Acmeda - Roller Blind Motorisation - Wirefree

SPECIFICATIONS

Control Options

Paradigm Remotes feature a contemporary design with touch sensitive controls. Available in single and fifteen channel models, paradigm remotes are compatible with all ARC motors. An LCD with levelling control features on the 15 channel remote, allowing for precise positioning of your blind.



Remote

Descr: Paradigm 5CH ARC Remote (5 Channel)

Automate Pulse/App

Whether you are at home or away, you can accurately control your blinds via the animated interface on your smart phone. Bi-directional communication allows you to visualise the exact positioning of blinds whilst also tracking the battery levels. Within the app, automate hub allows you to group shades into rooms making it easier to operate multiple blinds at once. Timers are also available allowing you to control sunlight throughout the day. This can help with heat loss/gain and provide UV protection to furnishings.

Automate Pulse Specifications		Automate Pulse Capabilities	
Installation	Desktop or wall mounted	Accounts per Hub	5 (1 admin, 4 guests)
Power Input	SVDC/1A	Locations per account	5
Rated Current	500mA	Devices per Hub	30
Rated Power	<2.5W	Hubs per location	5
Standby Power	≤300mA	Rooms per location	30
Wi-Fi Network	802.11 b/g/n - 2.4GHz only	Scenes per location	20
Device Central Frequency	433MHz	Timers per location	20
Radio Coverage	30m for device control (indoors)	Connection: Ethernet and Wifi	
Protection Class	IP20		
Antenna	Built-in		
Working Temperature	-10 ° to 45 °		
Storage Temperature	-20 ° to 55 °		

Automate Pulse 2 Hub



Solar Panel Charger

The Rollease Acmeda® solar panel charger is great for hard to reach places. The solar panel will allow you to raise and lower your blinds once a day whilst maintaining a constant charge to the motor. The mono-silicon/crystal solar panel provides power in varied conditions including in shadow-cast and low light situations. Panels can also be wired in parallel to provide additional power for larger applications.

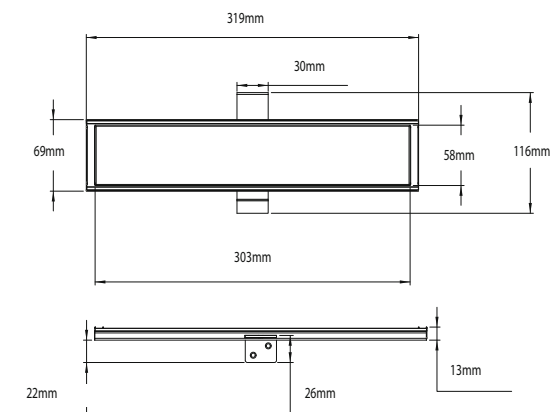
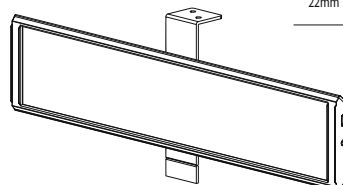

Pictured Solar Panel dimensions

Rollase Acmeda Blocco Roller Blinds Motorisation - Wired & Wirefree

Window Treatments offers wirefree and wired RollEase Acmeda motors capable of lifting up to 9.6kg. The Li-ion Battery powered motors are great for hard to reach places, especially when equipped with a solar panel. With the blinds being raised and lowered once a day, battery power will last approximately 3 months depending on fabric weight. A charging cable is provided and must be connected to the motor for 6 hours to provide optimum charge (standard 4mtr length supplied, 1.22mtr and 2.44mtr extensions available as optional extras). Alternatively, a solar panel charger can be fitted in the window to keep the motor charged allowing two cycles per day (once up and once down).

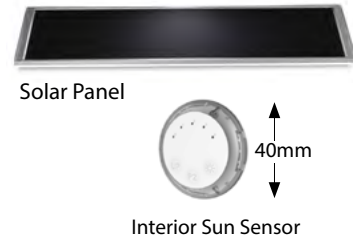

Minimum/Maximum Sizes

Window Treatments can produce a battery powered motorised roller blind to any size shown on the table. If your window is larger than our maximum size, our wired motorization offers more lifting capacity.

		Min -Max Blind Width for Li-ion Wirefree & Automate Hardwired Motors										
		610	740	1000	1250	1500	1750	2000	2250	2500	2750	3000
Drop	1250	[Grid with diagonal dashed lines indicating compatibility]										
	1500											
	1750											
	2000											
	2250											
	2500											
	2750											
	3000											

Key	Motor Type	Tube	Lifting Capacity
[Yellow]	1.1Nm Battery Motor	S45	3.6kg
[Green]	2.0Nm Battery Motor	S45	6.6kg
[Blue dashed]	6.0Nm Automate Hardwired	S45	24kg

Performances	Li-ion 1.1 Battery Motor	Li-ion 2.0 Battery Motor	Automate E6 Hardwired motor	Automate M6 Hardwired motor
Torque	1.1nm	2nm	6nm	6nm
Nominal Voltage	12v	12v	240v	240v
Rated Current (Amp)	0.96	1.25	0.85	0.85
Speed	20-24-28RPM	20-24-28RPM	33RPM	33RPM
Thermal Protection	12 Min	12 Min	4 Min	4 Min
Radio Frequency	433.92MHz	433.92MHz	433.92MHz	433.92MHz
Sound Level (DB)	46dB	46dB	44dB	44dB
IP Rating	IP 20	IP20	IP 44	IP 44
Insulation Class	III	III	III	III
Battery Size	2000mAH	2200mAH		

Compatibility Chart	Li-ion 1.1	Li-ion 2.0	Automate E6
Controller - Pulse	Y	Y	Y
Controller - Paradigm	Y	Y	Y
Sensor- Interior Sun Sensor	Y	Y	Y
Sensor - Solar Wind & Light	-	-	-
Sensor Motion Sensor	-	-	-

Technologies

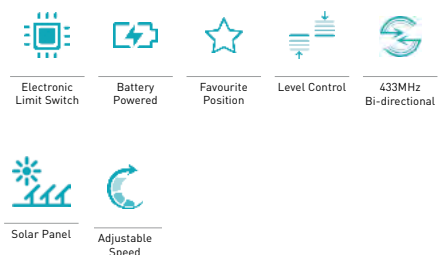

SPECIFICATIONS

RollEase® Acmeda

- Blocco Roller Blind Motorisation

To provide power to RollEase wired motors, Window Treatments uses an Inline Connector and when requested, conceals the Inline Connector inside a Flush Connector Housing. The RTS Inline Connector has a three core cable while the non-RTS Inline Connector has a four core cable. This allows rewiring from a non-RTS control to a RTS control

Flush Connector Housing

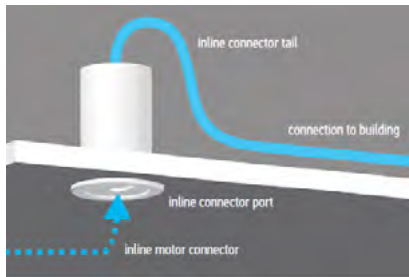

Technical Data	
Item Number	9026397
Item Description	Flush Connector Housing
Size	67 x 22 x 25mm
Colour	White
Patented Design	Au Pat 2018100721

Electrical requirements

Power Options:

Parallel Wiring - Do not wire RollEase® standard motors in parallel. Each motor requires its own switch or relays. If group control is required contact us for the required controller and wiring information.

Multiple Switching Wiring - Do not wire one motor directly to more than one switch. If multiple switching is required contact us for the required controller and wiring information.

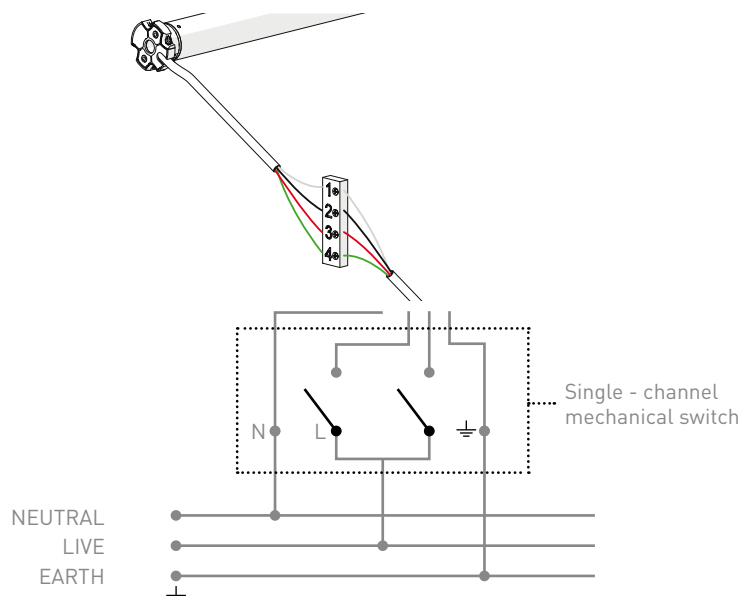

Sec. : Blocco
Date: May 2021



Rollease Acmeda - Blocco Roller Blind Motorisation - Wired & Wirefree

SPECIFICATIONS

Control Options

Paradigm Remotes feature a contemporary design with touch sensitive controls. Available in single and fifteen channel models, paradigm remotes are compatible with all ARC motors. An LCD with levelling control features on the 15 channel remote, allowing for precise positioning of your blind.



Remote

Descr: Paradigm 5CH ARC Remote (5 Channel)

Automate Pulse/App

Whether you are at home or away, you can accurately control your blinds via the animated interface on your smart phone. Bi-directional communication allows you to visualise the exact positioning of blinds whilst also tracking the battery levels. Within the app, automate hub allows you to group shades into rooms making it easier to operate multiple blinds at once. Timers are also available allowing you to control sunlight throughout the day. This can help with heat loss/gain and provide UV protection to furnishings.

Automate Pulse Specifications		Automate Pulse Capabilities	
Installation	Desktop or wall mounted	Accounts per Hub	5 (1 admin, 4 guests)
Power Input	SVDC/1A	Locations per account	5
Rated Current	500mA	Devices per Hub	30
Rated Power	<2.5W	Hubs per location	5
Standby Power	≤300mA	Rooms per location	30
Wi-Fi Network	802.11 b/g/n - 2.4GHz only	Scenes per location	20
Device Central Frequency	433MHz	Timers per location	20
Radio Coverage	30m for device control (indoors)	Connection: Ethernet and Wifi	
Protection Class	IP20		
Antenna	Built-in		
Working Temperature	-10 ° to 45 °		
Storage Temperature	-20 ° to 55 °		

Automate Pulse 2 Hub



Solar Panel Charger

The Rollease Acmeda® solar panel charger is great for hard to reach places. The solar panel will allow you to raise and lower your blinds once a day whilst maintaining a constant charge to the motor. The mono-silicon/crystal solar panel provides power in varied conditions including in shadow-cast and low light situations. Panels can also be wired in parallel to provide additional power for larger applications.

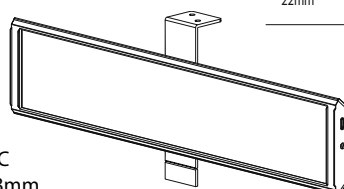
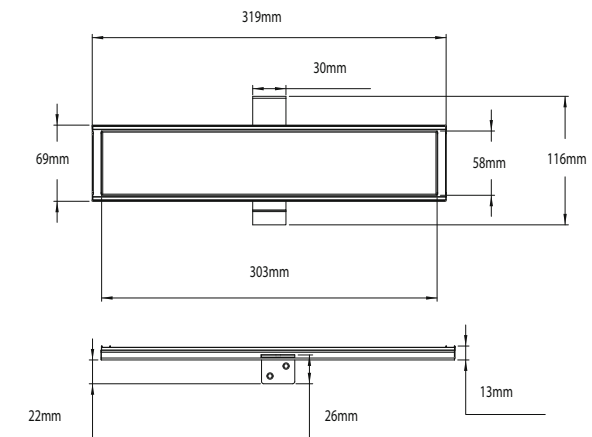

Pictured Solar Panel dimensions



Sec. : Blocco
Date: May 2021

Solar Panel

- Output voltage 12.6V
- Output power 2.73W
- Working Temperature: -20°C - 80°C
- Dimensions: 303mm x 58mm x 13mm

Blocco Honeycomb Blind

- Motorisation by Dooya or Manual Control

Motorised Operation:

For windows that are out of reach such as conservatories or some commercial installations, Window Treatments can motorise your Blocco Honeycomb blinds with a hard-wired Dooya 12v motor, or by an external rechargeable lithium battery. The raising and lowering of the blind is achieved with a rotating spool within the head rail which is driven by motor.

A small solar panel can also be connected to the battery pack to boost the operational life of the battery.

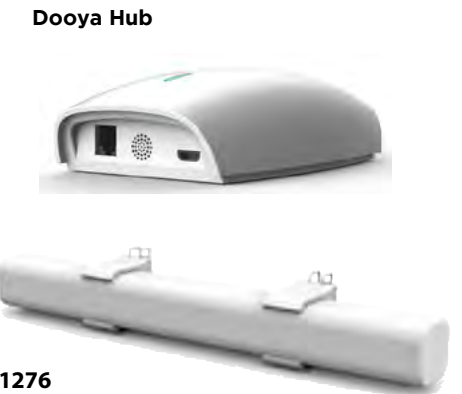
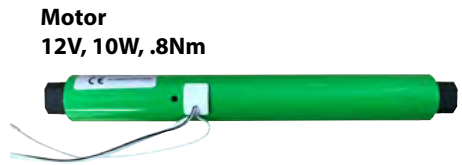
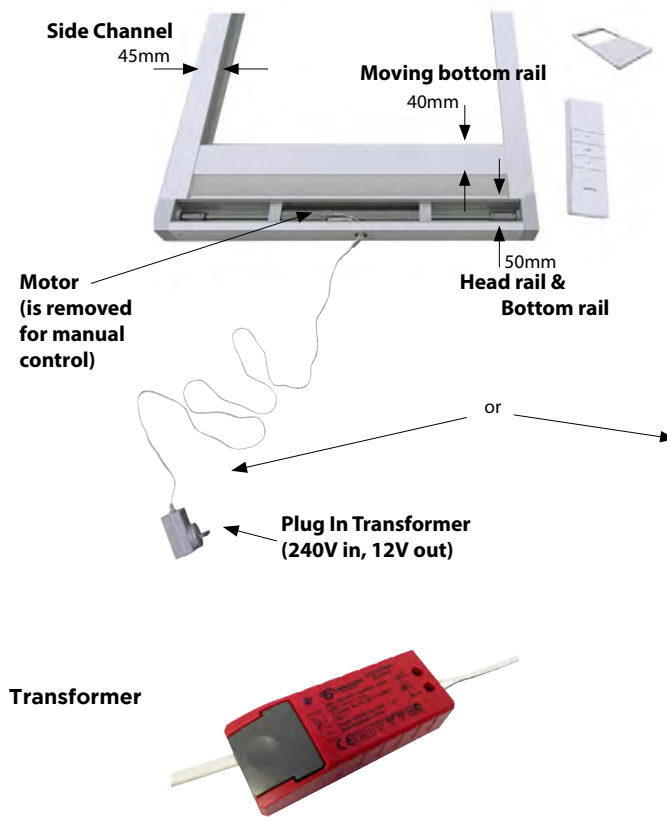

- For all DOOYA-DC motor (<12V, 20W)
- Power: 11.1V 2.6Ah
- Working life: 600 charging cycles
- Dimension: 225mm x 27.5mm x 27.5mm

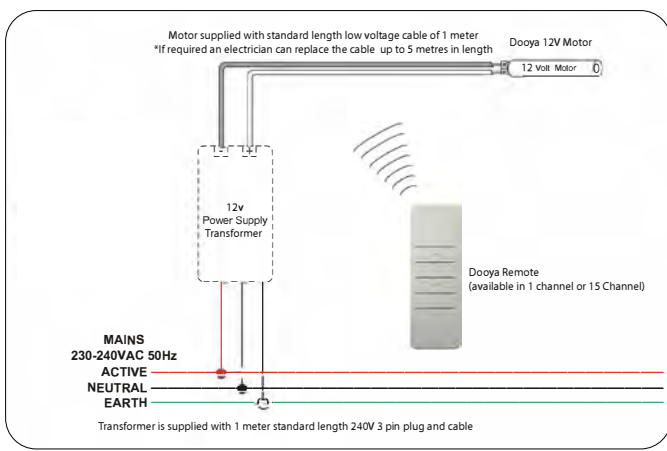

- Output voltage: 12.6V
- Output power: 3W
- Working Temperature: -20°C ~ + 80°C
- Service life: 5 years
- Dimension: 419mm x 54mm x 16mm

SPECIFICATIONS

Honeycomb Pleated - Dooya Motorisation

Motorised Operation:

For windows that are out of reach such as conservatories or some commercial installations, Window Treatments can motorise your Honeycomb pleated blinds with a hard-wired Dooya 12v motor, or by an external rechargeable lithium battery. The raising and lowering of the blind is achieved with a rotating spool within the head rail which is driven by motor. A small solar panel can also be connected to the battery pack to boost the operational life of the battery.

Control options: The blinds can be operated by remote and/or integrated into a BMS system via a Dooya HUB.

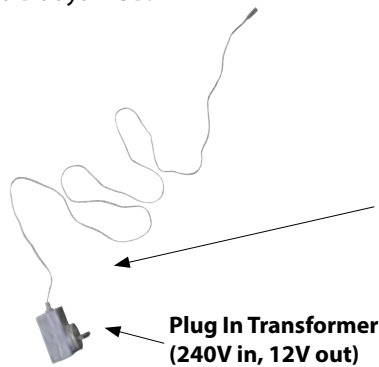

- DC1276**
12V Rechargeable Battery Wand
- For all DOOYA-DC motor (<12V, 20W)
 - Power: 11.1V 2.6Ah
 - Working life: 600 charging cycles
 - Dimension: 225mm x 27.5mm x 27.5mm

Dooya Hub



Motor
12V, 10W, .8Nm



- DC1289A**
Dooya Solar Panel
- Output voltage: 12.6V
 - Output power: 3W
 - Working Temperature: -20°C ~ + 80°C
 - Service life: 5 years
 - Dimension: 419mm x 54mm x 16mm

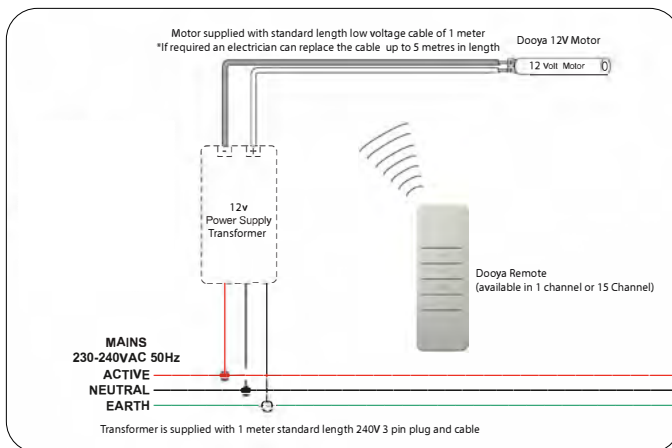

Head rail configuration

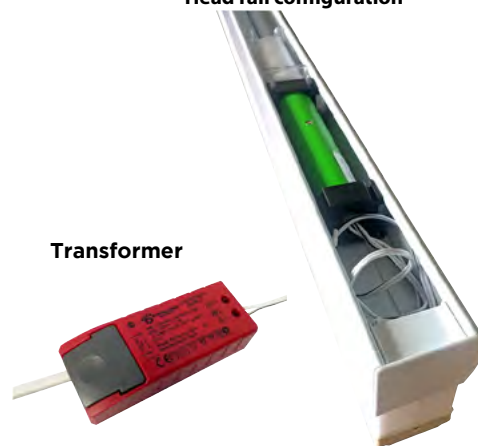

Honeycomb Pleated - Maximum Size Specifications

Control Type	Honeycomb Type (single cell)	Min / Max Blind Size			
		Max m ²	Min Width	Max Width	Max Drop
Clutch (cord on one side)	25mm	6.75 m ²	300mm	2700mm	2500mm
Clutch (cord on one side)	38mm	6.75 m ²	300mm	2700mm	3000mm
Motorised 12v with 230v transformer	25mm	6.75 m ²	840mm	2700mm	2500mm
Motorised 12v with Rechargeable Battery	38 mm	6.75 m ²	840mm	2700mm	2500mm

Sec. :Honeycomb Pleated
Date : May 2021

Shutters Motorised by Dooya

A Shutter 12v Motor Upgrade is available and is particularly useful where shutters are installed in "out of reach" places such as skylights and high gable-end windows.

- Shutter motors can also be installed onto existing shutters and on all types (Basswood, PVC, Aluminium & Cedar).
- The 12v rechargeable battery motor operates the louvre tilt only.
- Shutter Motors are white
- Charging of the battery is either by connecting a charger to the detachable battery and or, connecting a solar panel which is fixed onto or close to the glass. *See figure 2*
- The shutters motors are controlled by a 15-channel remote allowing multiple shutters to be controlled with one remote.
- **Rectangular shaped shutters:**
 - o The motor is fitted onto the stile facing the glass, so it is not easily seen from the inside. *See figure 1*
 - o The motor is fitted to the shutter stile on the opposite side to the Clear View Tilt Rod.
 - o The minimum height of the shutter panel to accommodate a Shutter Motor is 400mm
- **For Raking (sloping) shutters:**
 - o The motor is fitted onto the stile facing the glass so it is not easily seen from the inside. *See figure 1*
 - o The motor can only be fitted to the short side of the panel. The clear View Tilt Rod is always fitted to the long side of the panel. *See figure 1*
 - o The minimum height of the short side of the shutter panel to accommodate a Shutter Motor is 400mm
- Shutter panels with a Clear View tilt bar can be joined together if requested to allow one motor to operate a shutter panel which has a mid-rail. *See figure 3*
- Shutter Panels with a Plantation Tilt Bar cannot be joined so a panel with a mid-rail requires two motors.

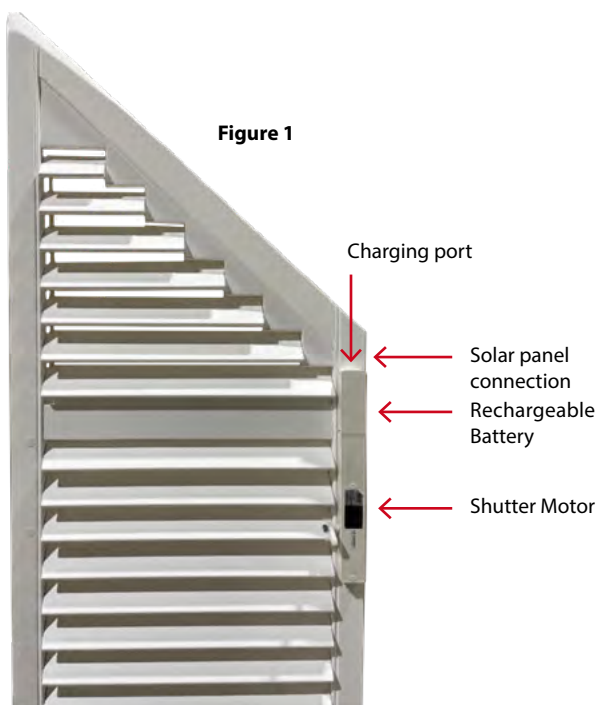

Figure 1

Figure 2

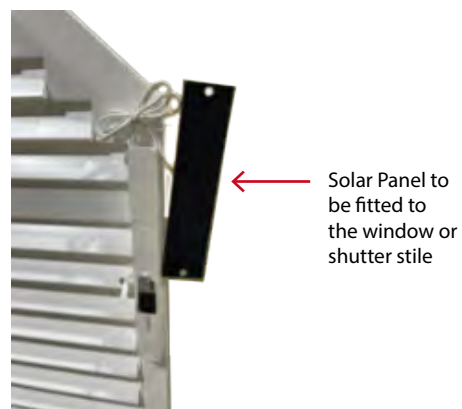

Figure 3



Shutter panels with a Clear view Tilt bar can be joined together if requested to allow one motor to operate a shutter which has a midrail

1. The motor and battery are always fitted to the short side of a raking shutter
2. In the example above, the rechargeable battery sits on top of the motor. If the motor is fitted to the opposite side of the shutter, the rechargeable battery sits under the motor

SPECIFICATIONS

Sec. : Shutters
Date : Dec 2023

Louvre Roof - Motorisation by Elero Picolla

Motorisation

- All Louvre Roofs are motorised with a retro-styled stainless steel 240v Elero Picolla XL-P (German) motor (Manual control is not available).
- Integrated isolation relays enabling parallel connection of several actuators.
- Weather-resistant 230V linear actuator made of stainless steel.
- Additional isolation relays are not required.
- Reduced installation expenditure and higher security against incorrect use.
- Control of several linear actuators in parallel (without synchronisation).
- Motor can be installed on either projection side of the louvre roof but the selected side must be stated on the order.
- Motor is installed on the top of the projection beam (100mm clear space is required above the projection beam the motor is installed upon).
- Louvres in the open position project 75mm beyond the top of the projection and cross beams therefore 75mm clear space must be provided on all beams and cross bars to allow for this rotation.
- Louvres in the open position are flush with the underside of the projection and cross beams.
- Control options are:
 - Somfy Remote with Receiver - optional upgrade with a Connexoon Automation Hub.
 - Hard wired to a wall switch or Hard wired to a Post mounted switch
- Wind or Rain Sensors. Note: it is not possible to install both a wind sensor and a rain sensor.



Somfy Remote



Post mounted switch

Electrical Connections

The Louvre Roof is installed by Window Treatments installers with a 240v Elero Pico XL-P external motor which is fastened to the middle of the top side, of one of the Projection Beams. The motor has a grey 4m power flex which is to be connected to the power supply by a registered Electrician. Window Treatments can recommend an electrician to complete this work if necessary. Power cables and connections can be installed by the registered Electrician, inside or outside the hollow louvre roof beams and posts, however all such work must conform to the Electrical Code.



Drive - Picollo XL-P motor with rod bracket attached

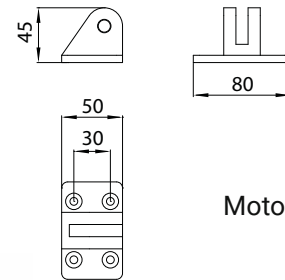

Motor bracket

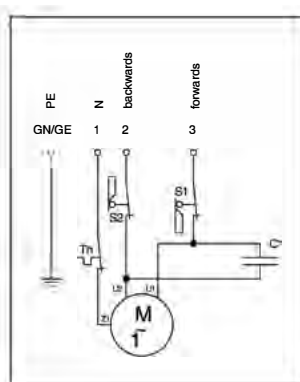

WS0800/230V 1AC

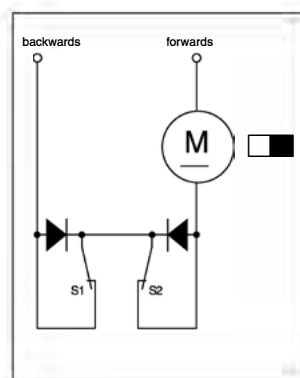

GS0300/24V DC

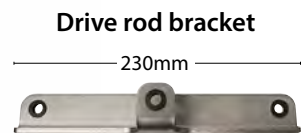

Drive rod bracket

- S1 = Limit switch piston rod out
- S2 = Limit switch piston rod in
- C1 = Capacitor (internal)
- Th = Thermal protection



SPECIFICATIONS

Sec. : Roller
Date: May 2021
Page: 22